

**FN510
Field Wireless
Multi-Function Module**

IM 01W03E01-01EN

FN510

Field Wireless Multi-Function Module

IM 01W03E01-01EN 3rd Edition

Contents

1.	Introduction.....	1-1
1.1	Safe Use of This Product	1-2
1.2	Warranty.....	1-2
1.3	ATEX Documentation	1-4
2.	Notes on Handling.....	2-1
2.1	Check the Model Name and Configuration	2-1
2.2	Transport.....	2-1
2.3	Storage	2-2
2.4	Selecting the Installation Location	2-2
2.5	Use of a Transceiver	2-3
2.6	Installation of an Explosion Protected Instrument	2-3
2.6.1	FM Approval (United States).....	2-4
2.6.2	FM Approval (Canada).....	2-10
2.6.3	ATEX Certification.....	2-16
2.6.4	IECEX Certification.....	2-18
2.7	EMC Conformity Standards	2-19
3.	Component Names	3-1
4.	Installation.....	4-1
4.1	Precautions.....	4-1
4.2	Mounting	4-1
4.2.1	Installation of FN110	4-1
4.2.2	Mounting of FN510	4-2
5.	Wiring.....	5-1
5.1	Notes on Wiring.....	5-1
5.2	Cable Selection	5-1
5.3	Installation and Connection of FN110	5-2
5.3.1	Installation of FN110	5-2
5.3.2	Connection of FN110	5-3
5.4	Connecting Input Signal Cable.....	5-3
5.4.1	Connecting Input Terminal and Grounding Terminal	5-3
5.5	Grounding.....	5-6

6.	Operation	6-1
6.1	Preparation for Starting Operation	6-1
6.2	Starting Operation	6-1
6.3	Connecting to the Field Wireless Network.....	6-2
6.4	Display Contents of the Integral Indicator	6-4
6.5	Shutting Down.....	6-4
7.	Setting Parameters	7-1
7.1	Preparation for Parameter Setting	7-1
7.2	Preparing Software	7-1
7.2.1	Softwares for the Field Wireless Configuration Tool and the Device Configuration Tool	7-1
7.2.2	Software Download.....	7-1
7.3	Setting Parameters	7-2
7.3.1	Parameter Usage and Selection.....	7-2
7.3.2	Function Block and Menu Tree	7-3
7.3.3	Parameters for Wireless Communication.....	7-7
7.3.4	Tag and Device Information	7-7
7.3.5	Setup the Integral Indicator.....	7-7
7.3.6	Sensor Type	7-7
7.3.7	Parameters for Function	7-8
7.3.8	Write Protect	7-8
7.3.9	Switching to the Deep Sleep Mode.....	7-8
7.3.10	Switching to the Silence Mode.....	7-9
7.4	Self-Diagnostics.....	7-10
7.4.1	Identify Problems by Using the Device Configuration Tool.....	7-10
7.4.2	Alert Report	7-10
7.4.3	Checking with Integral Indicator.....	7-11
8.	Maintenance	8-1
8.1	General	8-1
8.2	Recommended Products List.....	8-1
8.3	Replacing the Battery Pack	8-1
8.4	Replacing the Batteries	8-3
8.5	Handling Batteries	8-3
8.6	Switching LCD Display.....	8-4
8.7	Replacing the FN110.....	8-5
8.8	Replacing the FN510.....	8-5
8.9	Replacing the Connected Device	8-5
8.10	Troubleshooting.....	8-5
8.10.1	Basic Troubleshooting Flow.....	8-5
8.10.2	Example of Troubleshooting Flow	8-6
8.10.3	Errors and Countermeasures	8-7

9.	Parameter Summary	9-1
10.	General Specifications	10-1
10.1	Standard Specifications.....	10-1
10.2	Model and Suffix Codes	10-3
10.3	Optional Specification (For Explosion Protected Type).....	10-4
10.4	Optional Specifications.....	10-5
10.5	Optional Accessories	10-5
10.6	Dimensions.....	10-5
10.7	LCD Display Character List	10-7

Revision Information

1. Introduction

This manual describes how to use the FN510 Field Wireless Multi-Function Module (hereafter simply referred to as FN510).

FN510 was precisely calibrated at the factory before shipment. To ensure both safety and efficiency, please read this manual carefully before you operate this product.

FN510 works by utilizing the FN110 Field Wireless Communication Module (hereafter simply referred to as FN110). Please attach FN110 before use.

Table 1.1 summarizes the related document list of this manual.

Table 1.1 Related Document List

Title	Document No.
FieldMate Versatile Device Management Wizard User's Manual	IM 01R01A01-01E
YFGW710 Field Wireless Integrated Gateway User's Manual	IM 01W01F01-01EN
YFGW410 Field Wireless Management Station User's Manual	IM 01W02D01-01EN
FN110 Field Wireless Communication Module General Specifications	GS 01W03B01-01EN

■ Regarding This Manual

- This manual should be provided to the end user.
- The contents of this manual are subject to change without prior notice.
- All rights reserved. No part of this manual may be reproduced in any form without Yokogawa's written permission.
- Yokogawa makes no warranty of any kind with regard to this manual, including, but not limited to, implied warranty of merchantability and fitness for a particular purpose.
- If any question arises or errors are found, or if any information is missing from this manual, please inform the nearest Yokogawa sales office.
- The specifications covered by this manual are limited to those for the standard type under the specified model number break-down and do not cover custom-made products.

- Please note that changes in the specifications, construction, or component parts of this product may not immediately be reflected in this manual at the time of change, provided that postponement of revisions will not cause difficulty to the user from a functional or performance standpoint.
- Yokogawa assumes no responsibilities for this product except as stated in the warranty.
- If the customer or any third party is harmed by the use of this product, Yokogawa assumes no responsibility for any such harm owing to any defects in the product which were not predictable, or for any indirect damages.
- The following safety symbols are used in this manual:



WARNING

Indicates a potentially hazardous situation which, if not avoided, could result in death or serious injury.



CAUTION

Indicates a potentially hazardous situation which, if not avoided, may result in minor or moderate injury or physical damage. It may also be used to alert against unsafe practices.



IMPORTANT

Indicates that operating the hardware or software in this manner may damage it or lead to system failure.



NOTE

Draws attention to information essential for understanding the operation and features.

1.1 Safe Use of This Product

For the safety of the operator and to protect this product and the system, please be sure to follow this manual's safety instructions when handling this product. If these instructions are not heeded, the protection provided by this product may be impaired. In this case, Yokogawa cannot guarantee that this product can be safely operated. Please pay special attention to the following points:

(a) Installation

- This product may only be installed by an engineer or technician who has an expert knowledge of this product. Operators are not allowed to carry out installation unless they meet this condition.
- With high process temperatures, care must be taken not to burn yourself by touching this product or its casing.
- All installation shall comply with local installation requirements and the local electrical code.

(b) Wiring

- This product must be installed by an engineer or technician who has an expert knowledge of this product. Operators are not permitted to carry out wiring unless they meet this condition.

(c) Maintenance

- Please carry out only the maintenance procedures described in this manual. If you require further assistance, please contact the nearest Yokogawa office.
- Care should be taken to prevent the build up of dust or other materials on the display glass and the nameplate. To clean these surfaces, use a soft, dry cloth.

(d) Explosion Protected Type Instrument

- Users of explosion protected instruments should refer first to section 2.6 (Installation of an Explosion Protected Instrument) of this manual.
- The use of this instrument is restricted to those who have received appropriate training in the device.
- Take care not to create sparks when accessing the instrument or peripheral devices in a hazardous location.
- Repair or modification to this instrument by customer will cause malfunction of explosion protect function and hazardous situation. If you need to repair or modification, please contact the nearest Yokogawa office.

(e) Modification

- Yokogawa will not be liable for malfunctions or damage resulting from any modification made to this product by the customer.

1.2 Warranty

- The warranty shall cover the period noted on the quotation presented to the purchaser at the time of purchase. Problems occurring during the warranty period shall basically be repaired free of charge.
- If any problems are experienced with this product, the customer should contact the Yokogawa representative from which this product was purchased or the nearest Yokogawa office.
- If a problem arises with this product, please inform us of the nature of the problem and the circumstances under which it developed, including the model specification and serial number. Any diagrams, data and other information you can include in your communication will also be helpful.
- The party responsible for the cost of fixing the problem shall be determined by Yokogawa following an investigation conducted by Yokogawa.

■ **The purchaser shall bear the responsibility for repair costs, even during the warranty period, if the malfunction is due to:**

- Improper and/or inadequate maintenance by the purchaser.
- Malfunction or damage due to a failure to handle, use, or store this product in accordance with the design specifications.
- Use of the product in question in a location not conforming to the standards specified by Yokogawa, or due to improper maintenance of the installation location.
- Failure or damage due to modification or repair by any party except Yokogawa or an approved representative of Yokogawa.
- Malfunction or damage from improper relocation of the product in question after delivery.
- Reason of force majeure such as fires, earthquakes, storms/floods, thunder/lightening, or other natural disasters, or disturbances, riots, warfare, or radioactive contamination.

■ **Trademarks**

In this document, trademarks or registered trademarks are not marked with “™” or “®”. Product names and company names in this document are trademarks or registered trademarks of the respective companies.

■ **Authorized Representative in the EEA**

The Authorized Representative for this product in the EEA is: Yokogawa Europe B.V.

Euroweg 2, 3825 HD Amersfoort, THE NETHERLANDS.

1.3 ATEX Documentation

This is only applicable to the countries in European Union.

<p>GB All instruction manuals for ATEX Ex related products are available in English, German and French. Should you require Ex related instructions in your local language, you are to contact your nearest Yokogawa office or representative.</p>	<p>SK Všetky návody na obsluhu pre prístroje s ATEX Ex sú k dispozícii v jazyku anglickom, nemeckom a francúzskom. V prípade potreby návodu pre Ex-prístroje vo Vašom národnom jazyku, skontaktujte prosím miestnu kanceláriu firmy Yokogawa.</p>
<p>DK Alle brugervejledninger for produkter relateret til ATEX Ex er tilgængelige på engelsk, tysk og fransk. Skulle De ønske yderligere oplysninger om håndtering af Ex produkter på eget sprog, kan De rette henvendelse herom til den nærmeste Yokogawa afdeling eller forhandler.</p>	<p>CZ Všechny uživatelské příručky pro výrobky, na něž se vztahuje nevybušné schválení ATEX Ex, jsou dostupné v angličtině, němčině a francouzštině. Požadujete-li pokyny týkající se výrobků s nevybušným schválením ve vašem lokálním jazyku, kontaktujte prosím vaši nejbližší reprezentační kancelář Yokogawa.</p>
<p>I Tutti i manuali operativi di prodotti ATEX contrassegnati con Ex sono disponibili in inglese, tedesco e francese. Se si desidera ricevere i manuali operativi di prodotti Ex in lingua locale, mettersi in contatto con l'ufficio Yokogawa più vicino o con un rappresentante.</p>	<p>LT Visos gaminio ATEX Ex kategorijos Eksploatavimo instrukcijos teikiami anglų, vokiečių ir prancūzų kalbomis. Norėdami gauti prietaisų Ex dokumentaciją kitomis kalbomis susisiekite su artimiausiu bendrovės "Yokogawa" biuru arba atstovu.</p>
<p>E Todos los manuales de instrucciones para los productos antiexplosivos de ATEX están disponibles en inglés, alemán y francés. Si desea solicitar las instrucciones de estos artículos antiexplosivos en su idioma local, deberá ponerse en contacto con la oficina o el representante de Yokogawa más cercano.</p>	<p>LV Visas ATEX Ex kategorijas izstrādājumu Lietošanas instrukcijas tiek piegādātas angļu, vācu un franču valodās. Ja vēlaties saņemt Ex ierīšu dokumentāciju citā valodā, Jums ir jāsazinās ar firmas Jokogava (Yokogawa) tuvāko ofisu vai pārstāvi.</p>
<p>NL Alle handleidingen voor producten die te maken hebben met ATEX explosiebeveiliging (Ex) zijn verkrijgbaar in het Engels, Duits en Frans. Neem, indien u aanwijzingen op het gebied van explosiebeveiliging nodig hebt in uw eigen taal, contact op met de dichtstbijzijnde vestiging van Yokogawa of met een vertegenwoordiger.</p>	<p>EST Kõik ATEX Ex toodete kasutamishendid on esitatud inglise, saksa ja prantsuse keeles. Ex seadmete muukeelse dokumentatsiooni saamiseks pöörduge lähima lokagava (Yokogawa) kontori või esindaja poole.</p>
<p>SF Kaikkien ATEX Ex -tyyppisten tuotteiden käyttöohjeet ovat saatavilla englannin-, saksan- ja ranskankielisinä. Mikäli tarvitsette Ex -tyyppisten tuotteiden ohjeita omalla paikallisella kielellänne, ottakaa yhteyttä lähimpään Yokogawa-toimistoon tai -edustajaan.</p>	<p>PL Wszystkie instrukcje obsługi dla urządzeń w wykonaniu przeciwwybuchowym Ex, zgodnych z wymaganiami ATEX, dostępne są w języku angielskim, niemieckim i francuskim. Jeżeli wymagana jest instrukcja obsługi w Państwa lokalnym języku, prosimy o kontakt z najbliższym biurem Yokogawy.</p>
<p>P Todos os manuais de instruções referentes aos produtos Ex da ATEX estão disponíveis em Inglês, Alemão e Francês. Se necessitar de instruções na sua língua relacionadas com produtos Ex, deverá entrar em contacto com a delegação mais próxima ou com um representante da Yokogawa.</p>	<p>SLO Vsi predpisi in navodila za ATEX Ex sorodni pridelki so pri roki v angleščini, nemščini ter francoščini. Če so Ex sorodna navodila potrebna v vašem tujejnem jeziku, kontaktirajte vaš najbližji Yokogawa office ili predstavnika.</p>
<p>F Tous les manuels d'instruction des produits ATEX Ex sont disponibles en langue anglaise, allemande et française. Si vous nécessitez des instructions relatives aux produits Ex dans votre langue, veuillez bien contacter votre représentant Yokogawa le plus proche.</p>	<p>H Az ATEX Ex műszerek gépkönyveit angol, német és francia nyelven adjuk ki. Amennyiben helyi nyelven kérik az Ex eszközök leírásait, kérjük keressék fel a legközelebbi Yokogawa irodát, vagy képviselőt.</p>
<p>D Alle Betriebsanleitungen für ATEX Ex bezogene Produkte stehen in den Sprachen Englisch, Deutsch und Französisch zur Verfügung. Sollten Sie die Betriebsanleitungen für Ex-Produkte in Ihrer Landessprache benötigen, setzen Sie sich bitte mit Ihrem örtlichen Yokogawa-Vertreter in Verbindung.</p>	<p>BG Всички упътвания за продукти от серията ATEX Ex се предлагат на английски, немски и френски език. Ако се нуждаете от упътвания за продукти от серията Ex на родния ви език, се свържете с най-близкия офис или представителство на фирма Yokogawa.</p>
<p>S Alla instruktionsböcker för ATEX Ex (explosionssäkra) produkter är tillgängliga på engelska, tyska och franska. Om Ni behöver instruktioner för dessa explosionssäkra produkter på annat språk, skall Ni kontakta närmaste Yokogawakontor eller representant.</p>	<p>RO Toate manualele de instructiuni pentru produsele ATEX Ex sunt in limba engleza, germana si franceza. In cazul in care doriti instructiunile in limba locala, trebuie sa contactati cel mai apropiat birou sau reprezentant Yokogawa.</p>
<p>GR Όλα τα εγχειρίδια λειτουργίας των προϊόντων με ATEX Ex διατίθενται στα Αγγλικά, Γερμανικά και Γαλλικά. Σε περίπτωση που χρειάζεστε οδηγίες σχετικά με Ex στην τοπική γλώσσα παρακαλούμε επικοινωνήστε με το πλησιέστερο γραφείο της Yokogawa ή αντιπρόσωπο της.</p>	<p>M Il-manwali kollha ta' I-istruzzjonijiet għal prodotti marbuta ma' ATEX Ex huma disponibbli bl-Ingliż, bil-Ġermaniż u bil-Franċiż. Jekk tkun teħtieġ struzzjonijiet marbuta ma' Ex fil-lingwa lokali tiegħek, għandek tikkuntattja lill-eqreb rappreżentant jew uffičċju ta' Yokogawa.</p>

F0101.ai

2. Notes on Handling

The FN510 is fully factory-tested before shipment. When the FN510 delivered, check the appearance for damage, and also check that the mounting parts shown in Figure 2.1 are included with your shipment. If “No Mounting Bracket” or “Horizontal connection” is indicated, no mounting bracket is included.

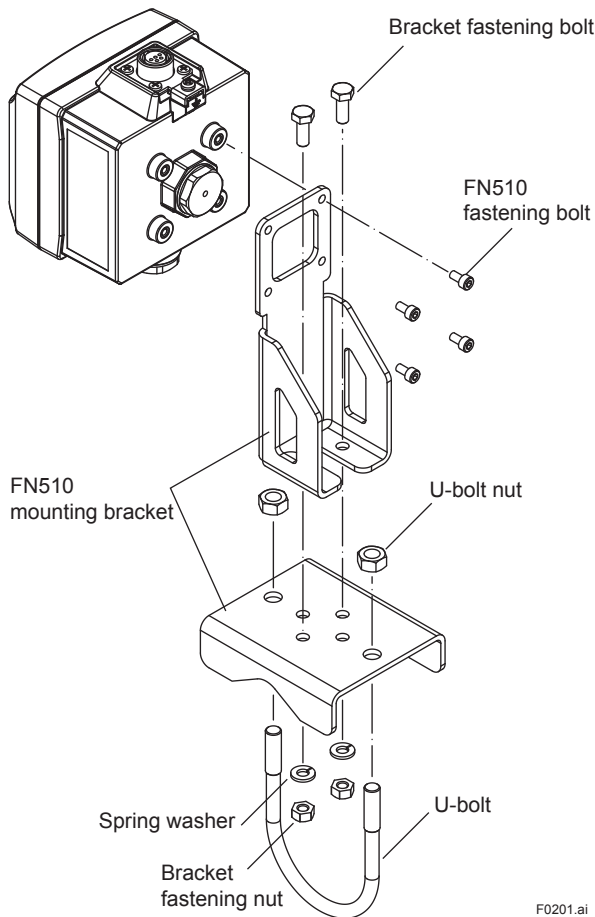

Figure 2.1 FN510 Mounting Hardware

Table 2.1 FN510 Mounting Hardware

Item	Qty
FN510 mounting bracket	1
FN510 fastening bolt	4
Bracket fastening bolt	2
Bracket fastening nut	2
Spring washer	2
U-bolt	1
U-bolt nut	2

■ Bundled Items

- User’s Manual (IM01W03E01-01EN)
- FN510 mounting hardware
When specified mounting bracket.
- Protection cap (optional specifications)
- Wired tag plate(optional specifications)

2.1 Check the Model Name and Configuration

The model name and configuration are indicated on the nameplate. Verify that the configuration indicated in the “Model and Suffix Code” in subsection 10.2 is in compliance with the specifications written on the order sheet. Manual number omitting the language code at the end is printed on the nameplate.

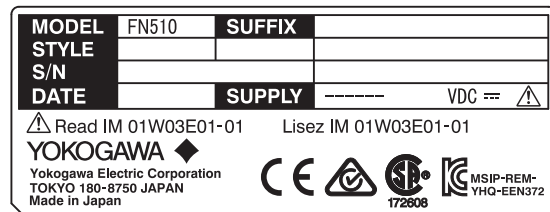

F0202.ai

Figure 2.2 Nameplate

MODEL : Specified model code.
 SUFFIX : Specified suffix code.
 STYLE : Style code.
 S/N : Serial number.
 DATE : Date of manufacture.
 SUPPLY : Supply voltage.
 TOKYO 180-8750 JAPAN: The manufacturer name and the address *1.

*1 “180-8750” is a zip code which represents the following address. 2-9-32 Nakacho, Musashino-shi, Tokyo Japan

2.2 Transport

To prevent damage while in transit, leave the FN510 in the original shipping container until it reaches the installation site. For transportation of batteries, refer to subsection 8.5 “Handling Batteries”.

2.3 Storage

When storing this product, observe the following precautions.

1. Chose a storage location that satisfies the following requirements.
 - A location that is not exposed to rain or water.
 - A location subject to a minimum of vibration or impact.
 - The following temperature and humidity range is recommended. Ordinary temperature and humidity (25°C, 65%) are preferable.
 Temperature: -40 to 85°C
 Humidity : 0 to 100% RH
 (no condensation)
2. If at all possible, store the FN510 in factory-shipped condition, that is, in the original shipping container.
3. Preferably remove the batteries for storage. For maximum battery life, the storage temperature should not exceed 30°C.



NOTE

When storing FN510 with a battery pack, it is recommended to put the FN510 in Deep Sleep mode to conserve the batteries. For details on how to switch to Deep Sleep mode, refer to subsection 7.3.9 “Switching to the Deep Sleep Mode”.

2.4 Selecting the Installation Location

Although this product is designed to operate in a harsh environment, to maintain stability and accuracy, the following is recommended.

■ Wireless Communication



NOTE

The installation location of this product must meet the following conditions:

- Install this product to be perpendicular to the ground.
- When using a remote antenna cable, regardless of the installing direction of the FN510, install the FN110 to be perpendicular to the ground.
- Install the FN110 at least 1.5 m above the ground or floor.

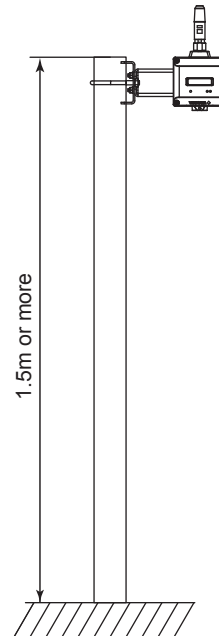

F0203.ai

- Ensure that there are no obstacles such as walls or pipes within a 30 cm radius of the FN110.
 - Confirm that each field wireless equipment can see the antenna of other devices which locate within its own communication range.
-

■ **Ambient Temperature**

It is preferable to not to expose the instrument to extreme temperatures or temperature fluctuations. If FN510 is exposed to radiation heat a thermal protection system or appropriate ventilation is recommended.

■ **Environmental Requirements**

Do not allow FN510 to be installed in a location that is exposed to corrosive atmospheric conditions. When using this product in a corrosive environment, ensure the location is well ventilated. The unit and its wiring should be protected from exposure to rainwater.

■ **Impact and Vibration**

It is recommended that the FN510 be installed in a location that is subject to a minimum amount of impact and vibration.

■ **Installation of Explosion Protected Products**

An explosion protected products is certified for installation in a hazardous area containing specific gas types. See subsection 2.6 “Installation of an Explosion Protected Instrument”.

2.5 Use of a Transceiver



IMPORTANT

Although FN510 has been designed to resist high frequency electrical noise, if a radio transceiver is used near the FN510 or its external wiring, the FN510 may be affected by high frequency noise pickup. To test this, start out from a distance of several meters and slowly approach the FN510 with the transceiver while observing the measurement loop for noise effects. Thereafter use the transceiver outside the range where the noise effects were first observed.

2.6 Installation of an Explosion Protected Instrument

If a customer makes a repair or modification to an intrinsically safe instrument and the instrument is not restored to its original condition, its intrinsically safe construction may be compromised and the instrument may be hazardous to operate. Please contact Yokogawa before making any repair or modification to an instrument.



WARNING

- Electrostatic charge may cause an explosion hazard. Avoid any actions that cause the generation of electrostatic charge, such as rubbing surface of the product with a dry cloth.
- To satisfy IP66, IP67 and Type 4X,
 - Connect to a connector JR13WPI-5P (Hirose Electric) and tightened with a specified torque.
 - Apply waterproof glands to the electrical connection port, at models FN510-xx-x00, FN510-xx-x01, and FN510-xx-x02.
- The instrument modification or parts replacement by other than an authorized representative of Yokogawa Electric Corporation is prohibited and will void the certification.
- When replacing the battery pack, be sure to minimize the risk of explosion from electrostatic discharge. Avoid any actions that cause the generation of electrostatic charge, such as rubbing surface of the battery pack and product with a dry cloth.



CAUTION

- This instrument has been tested and certified as being intrinsically safe. Please note that severe restrictions apply to this instrument's construction, installation, external wiring, maintenance and repair. A failure to abide by these restrictions could make the instrument a hazard to operate.
- Be careful to make sure that an intrinsically safe apparatus, intrinsically safe devices, and wiring to connect them are arranged so that current and voltage are not induced by electromagnetic or electrostatic induction in the intrinsically safe circuit in order to prevent impairment of the intrinsically safe and explosion protected performance of the intrinsically safe circuit.

2.6.1 FM Approval (United States)

(1) Technical Data

Caution for FM Approval (US) Intrinsically safe type.

Note 1. Model FN510 Field Wireless Multi-Function Module with optional code /FS17 for potentially explosive atmospheres:

- Applicable Standards:
Class 3600:2011, Class 3610:2010,
Class 3810:2005, ANSI/ISA-60079-0-2013,
ANSI/ISA-60079-11-2014, NEMA 250-2003,
ANSI/IEC-60529-2004 (R2011)
- Intrinsically safe for Class I, II, III, Division 1,
Groups C, D, E, F & G, Class I, Zone 0, in
Hazardous Locations, AEx ia IIB
- Enclosure: Type 4X and IP66
- Temperature Class: T4
- Ambient Temperature: -40 to 70 °C (-40 to
158 °F)
- For connection to Class I, II, III, Division 1,
Groups A, B, C, D, E, F & G, Class I, Zone 0,
in Hazardous Locations, AEx ia IIC

Note 2. Electrical Parameters
(Refer to the Control Drawing)

Note 3. Installation

- Installation should be in accordance with
local installation requirements. (Refer to the
Control Drawing)

Model: FN510 series

Date: May 29, 2015

Control Drawing of FN510 (FN510-xx-AxxA, US / Canada)

DIDO

Hazardous (Classified) Location
 Class I, Division 1,
 Groups A, B, C, D
 Class II, Division 1,
 Groups E, F, G
 Class III, Division 1
 or
 Class I, Zone 0, Group IIC

Hazardous (Classified) Location
 Class I, Division 1,
 Groups C, D
 Class II, Division 1,
 Groups E, F, G
 Class III, Division 1
 or
 Class I, Zone 0, Group IIB
 Temperature Class: T4

Hazardous (Classified) Location
 Class I, Division 1,
 Groups A, B, C, D
 Class II, Division 1,
 Groups E, F, G
 Class III, Division 1
 or
 Class I, Zone 0, Group IIC

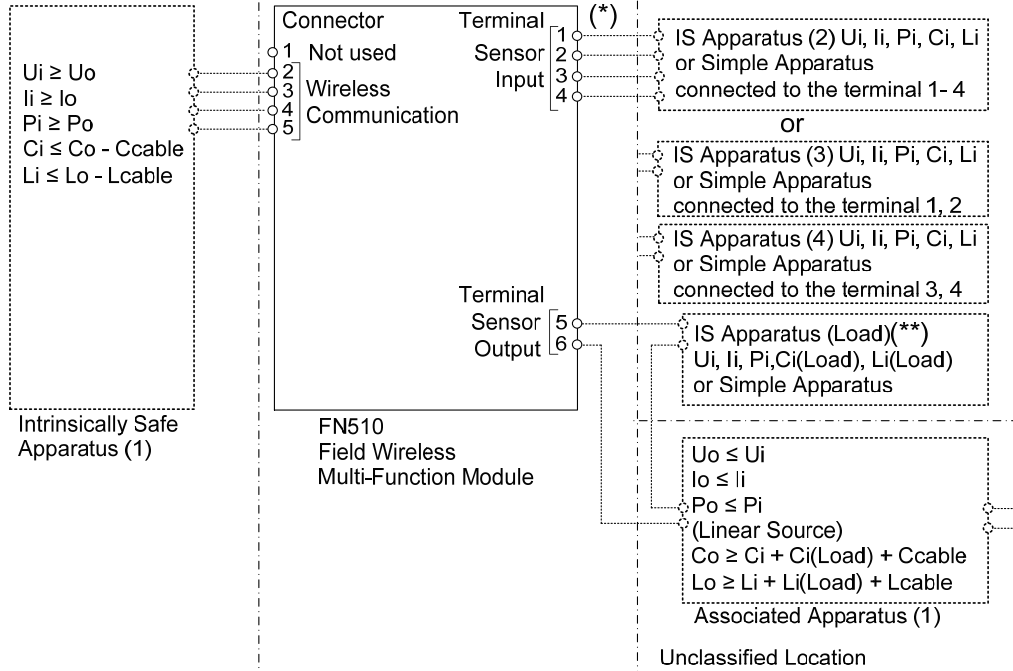

Wireless Communication (Connector)	Sensor Input (Terminal 1 to 4)	Sensor Output (Terminal 5, 6)
Uo : 5.88 V	Uo : 5.88 V	Ui : 30 V
lo : 483 mA	lo : 145 mA	li : 200 mA
Po : 779 mW	Po : 213 mW	Pi : 1 W
Co : 5.82 μF	Co : 43 μF	Ci : 10 nF
Lo : 25 μH	Lo : 1.6 mH	Li : 0 μH

(*) If the Intrinsically Safe Apparatus are connected to Terminal 1- 4, entity parameters shall be satisfied as shown below:

Ui ≥ Uo, li ≥ lo, Pi ≥ Po, Ci, Li: See Note 1

(**) "Load" is a solenoid valve, a relay coil, or a lamp.

Rev.

Doc. No. : IFM045-A81 P.1

Yokogawa Electric Corporation

Model: FN510 series

Date: May 29, 2015

AI (1)

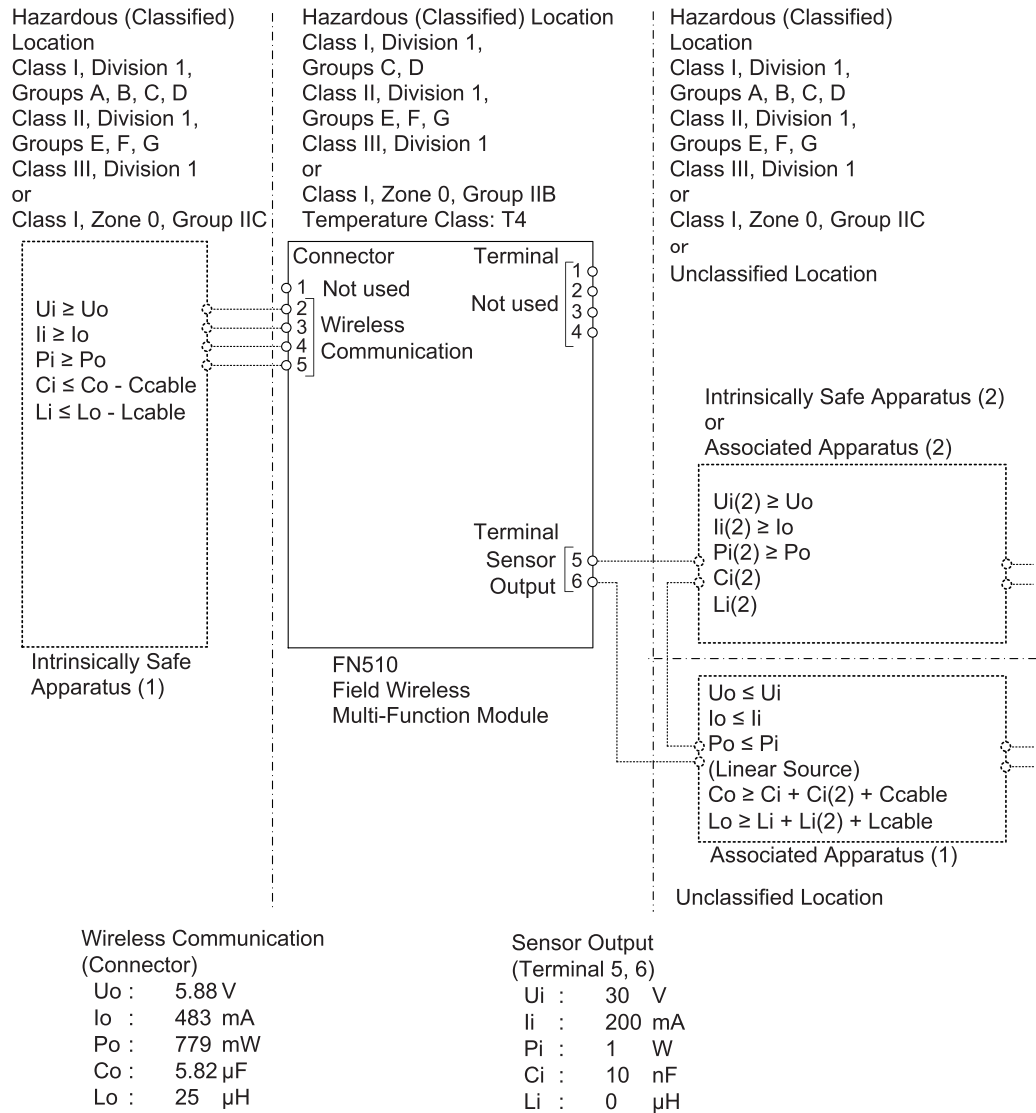

Rev.

Doc. No. : IFM045-A81 P.2

Yokogawa Electric Corporation

Model: FN510 series

Date: May 29, 2015

AI (2)

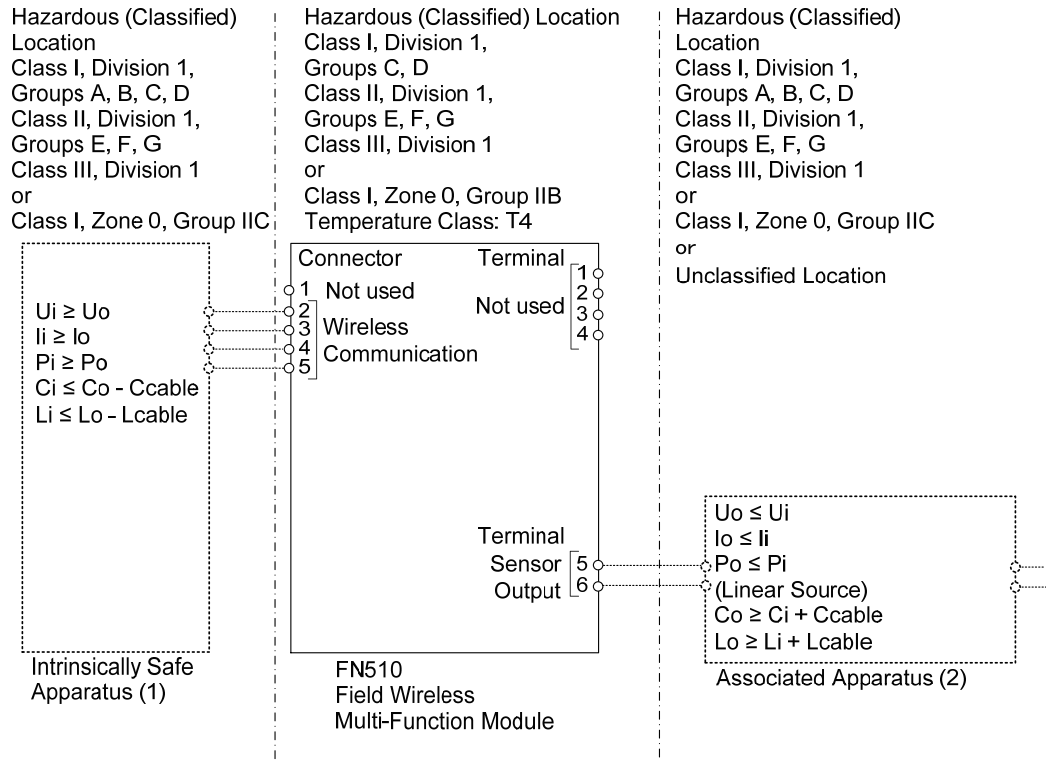

Wireless Communication (Connector)
 U_o : 5.88 V
 I_o : 483 mA
 P_o : 779 mW
 C_o : 5.82 μ F
 L_o : 25 μ H

Sensor Output (Terminal 5, 6)
 U_i : 30 V
 I_i : 200 mA
 P_i : 1 W
 C_i : 10 nF
 L_i : 0 μ H

Rev.

Doc. No. : IFM045-A81 P.3

Yokogawa Electric Corporation

Model: FN510 series

Date: May 29, 2015

PULSE

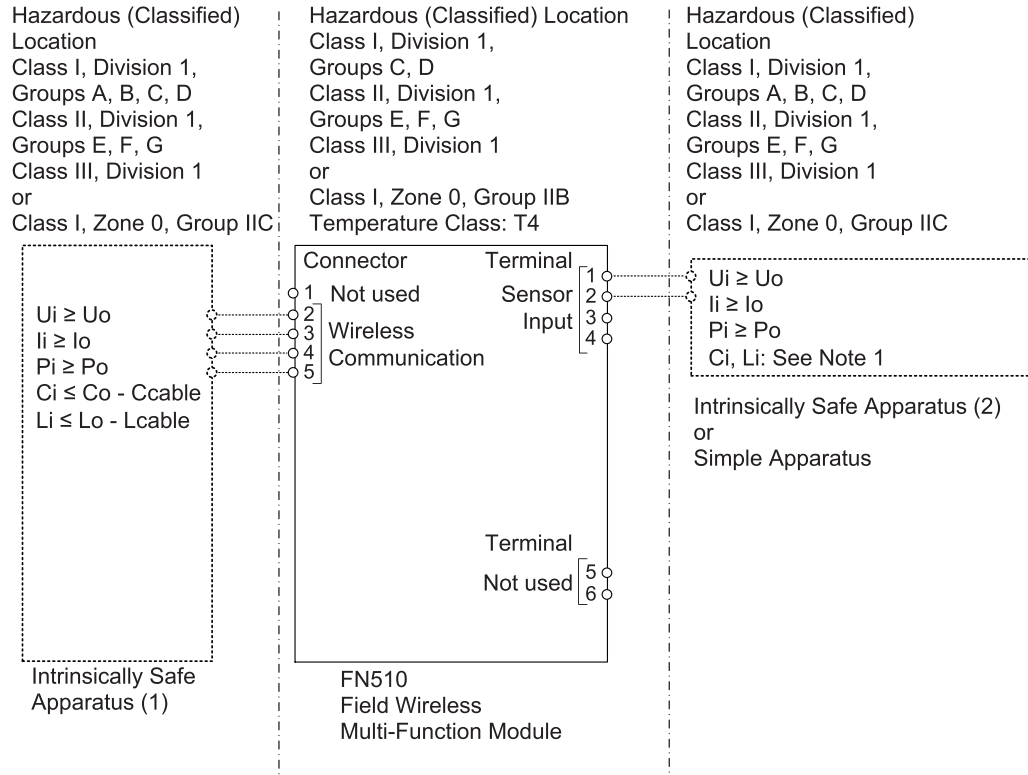

Wireless Communication (Connector)

Uo :	5.88 V
Io :	483 mA
Po :	779 mW
Co :	5.82 μF
Lo :	25 μH

Sensor Input (Terminal 1 to 4)

Uo :	5.88 V
Io :	145 mA
Po :	213 mW
Co :	43 μF
Lo :	1.6 mH

Specific Conditions of Use:

- Precautions shall be taken to minimize the risk from electrostatic discharge of non-metallic parts. When the equipment is used in hazardous locations, avoid any actions which generate electrostatic charges, such as rubbing with a dry cloth.
- The connector on the enclosure contains aluminum and is considered a potential risk of ignition caused by impact or friction. When the equipment is used in Zone 0, it must be installed such that, even in the event of rare incidents, ignition sources due to impact and/or friction sparks are excluded.
- Rigid type conduit shall not be used as the wiring method.

Rev.

Doc. No. : IFM045-A81 P.4

Yokogawa Electric Corporation

Model: FN510 series

Date: May 29, 2015

Notes:

1. As allowable connection values of an Intrinsically Safe Apparatus (2) or (3) and (4), the following conditions of (a) or (b) must be satisfied.
 (a) $\{(Li \times 100 \leq Lo) \text{ or } (Ci \times 100 \leq Co)\}$ and $\{Li \leq (Lo - Lcable) \text{ and } Ci \leq (Co - Ccable)\}$
 (b) $\{Li \leq (Lo / 2 - Lcable) \text{ and } Ci \leq (Co / 2 - Ccable)\}$ and
 $\{[(Ci + Ccable) \leq 600 \text{ nF for Group IIC}] \text{ or } [(Ci + Ccable) \leq 1\mu\text{F for Group IIA, IIB}]\}$
2. (For US) No revision to this drawing without prior approval of FM.
3. (For US) Installation must be in accordance with the National Electric Code (NFPA70), ANSI/ISA-RP12.06.01, and relevant local codes.
4. (For Canada) Installation must be in accordance with the Canadian Electrical Code Part I (C22.1), ANSI/ISA-RP12.06.01, and relevant local codes.
5. (For US) IS Apparatus (or Associated Apparatus) must be FM approved.
6. Control equipment connected to IS Apparatus (or Associated Apparatus) must not use or generate a voltage more than U_m of the control equipment.
7. The equipment satisfies the requirements for IP66 and Type 4X only when it is connected to a connector JR13WPI-5P (Hirose Electric) and tightened with a torque of 1.2-2.0 N·m. Appropriate type of plug must be used in accordance with the instructions.
8. The control drawing of IS Apparatus (or Associated Apparatus) must be followed when installing the equipment.
9. WARNING – POTENTIAL ELECTROSTATIC CHARGING HAZARD – WHEN THE EQUIPMENT IS USED IN HAZARDOUS LOCATIONS, AVOID ANY ACTIONS WHICH GENERATE ELECTROSTATIC CHARGES, SUCH AS RUBBING WITH A DRY CLOTH
10. WARNING – WHEN THE EQUIPMENT IS USED IN ZONE 0, IT MUST BE INSTALLED SUCH THAT, EVEN IN THE EVENT OF RARE INCIDENTS, IGNITION SOURCES DUE TO IMPACT AND FRICTION SPARKS ARE EXCLUDED
11. WARNING – TO PREVENT IGNITION OF FLAMMABLE OR COMBUSTIBLE ATMOSPHERES, READ, UNDERSTAND AND ADHERE TO THE MANUFACTURE'S LIVE MAINTENANCE PROCEDURE
12. WARNING – USE ONLY YOKOGAWA BATTERY PACK F9090FC or F9090GC
13. WARNING – THE BATTERY PACK CAN BE REPLACED IN A HAZARDOUS LOCATION. THE BATTERY PACK HAS SURFACE RESISTIVITY GREATER THAN 1G OHM AND MUST BE PROPERLY INSTALLED IN THE ENCLOSURE OF THE EQUIPMENT. CARE MUST BE TAKEN DURING TRANSPORTATION TO AND FROM THE POINT OF INSTALLATION TO PREVENT ELECTROSTATIC CHARGE BUILD-UP
14. WARNING – CELLS MUST BE CHANGED IN AN UNCLASSIFIED LOCATION ONLY
15. WARNING – SUBSTITUTION OF COMPONENTS MAY IMPAIR INTRINSIC SAFETY

Rev.

Doc. No. : IFM045-A81 P.5

Yokogawa Electric Corporation

F0208.ai

**WARNING**

- Be sure to use the specified battery pack and batteries. For details, refer to section 8.5 “Handling Batteries.”
- With an intrinsically safe Products, the battery pack is replaceable in a hazardous area. During the replacement work, make sure that dust and water droplets do not enter inside the products. For details on how to replace the battery pack, refer to section 8.3 “Replacing the Battery Pack.”

2.6.2 FM Approval (Canada)**(1) Technical Data**

Caution for FM Approval (Canada) Intrinsically safe type.

Note 1. Model FN510 Field Wireless Multi-Function Module with optional code /CS17 for potentially explosive atmospheres:

- Applicable Standards:
CAN/CSA-C22.2 No. 0-10 (R2015),
CAN/CSA-C22.2 No. 94.1-07 (R2012),
CAN/CSA-C22.2 No. 94.2-07 (R2012),
CAN/CSA-C22.2 No. 60079-0:11,
CAN/CSA-C22.2 No. 60079-11:14,
CAN/CSA-C22.2 No. 60529-05 (R2015),
CAN/CSA-C22.2 No. 61010-1-12
- Ex ia [ia IIC] IIB T4 Ga
- Intrinsically safe for Class I, II, III, Division 1, Groups C, D, E, F & G
- Enclosure: Type 4X and IP66
- Temperature Class: T4
- Ambient Temperature: –40 to 70 °C (–40 to 158 °F)
- For connection to Class I, II, III, Division 1, Groups A, B, C, D, E, F & G

Note 2. Electrical Parameters
(Refer to the Control Drawing)

Note 3. Installation

- Installation should be in accordance with local installation requirements.
(Refer to the Control Drawing)

Model: FN510 series

Date: May 29, 2015

Control Drawing of FN510 (FN510-xx-AxxA, US / Canada)

DIDO

Hazardous (Classified) Location
 Class I, Division 1,
 Groups A, B, C, D
 Class II, Division 1,
 Groups E, F, G
 Class III, Division 1
 or
 Class I, Zone 0, Group IIC

Hazardous (Classified) Location
 Class I, Division 1,
 Groups C, D
 Class II, Division 1,
 Groups E, F, G
 Class III, Division 1
 or
 Class I, Zone 0, Group IIB
 Temperature Class: T4

Hazardous (Classified) Location
 Class I, Division 1,
 Groups A, B, C, D
 Class II, Division 1,
 Groups E, F, G
 Class III, Division 1
 or
 Class I, Zone 0, Group IIC

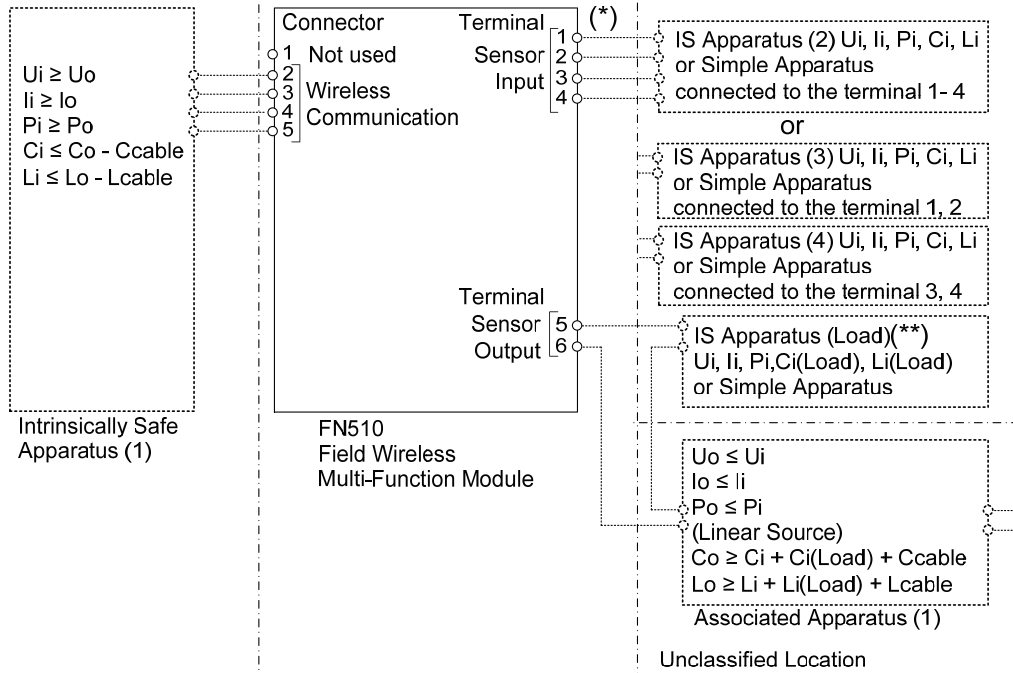

Wireless Communication (Connector)	Sensor Input (Terminal 1 to 4)	Sensor Output (Terminal 5, 6)
Uo : 5.88 V	Uo : 5.88 V	Ui : 30 V
Io : 483 mA	Io : 145 mA	li : 200 mA
Po : 779 mW	Po : 213 mW	Pi : 1 W
Co : 5.82 μF	Co : 43 μF	Ci : 10 nF
Lo : 25 μH	Lo : 1.6 mH	Li : 0 μH

(*) If the Intrinsically Safe Apparatus are connected to Terminal 1- 4, entity parameters shall be satisfied as shown below:

Ui ≥ Uo, li ≥ lo, Pi ≥ Po, Ci, Li: See Note 1

(**) "Load" is a solenoid valve, a relay coil, or a lamp.

Rev.

Doc. No. : IFM045-A81 P.1

Yokogawa Electric Corporation

Model: FN510 series

Date: May 29, 2015

AI (1)

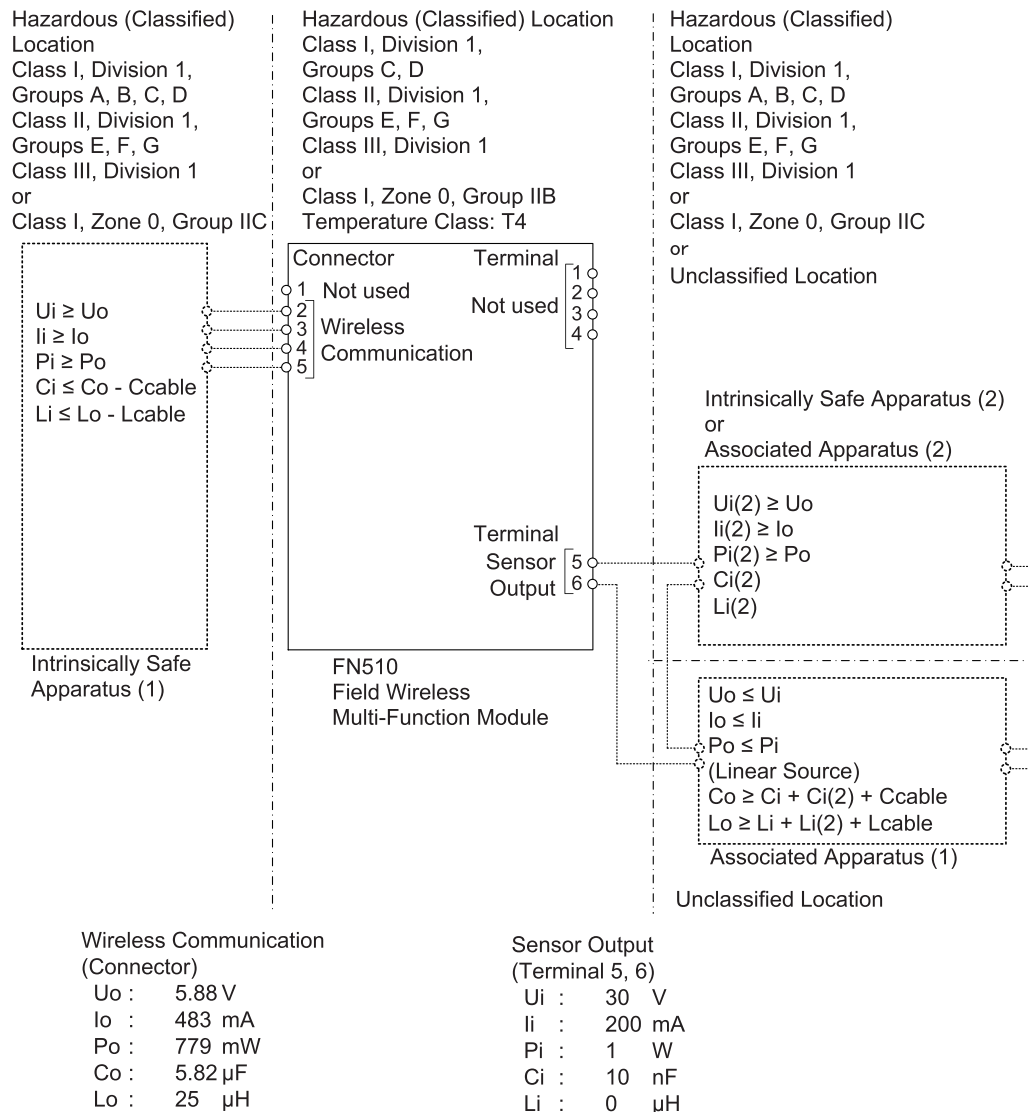

Rev.

Doc. No. : IFM045-A81 P.2

Yokogawa Electric Corporation

Model: FN510 series

Date: May 29, 2015

AI (2)

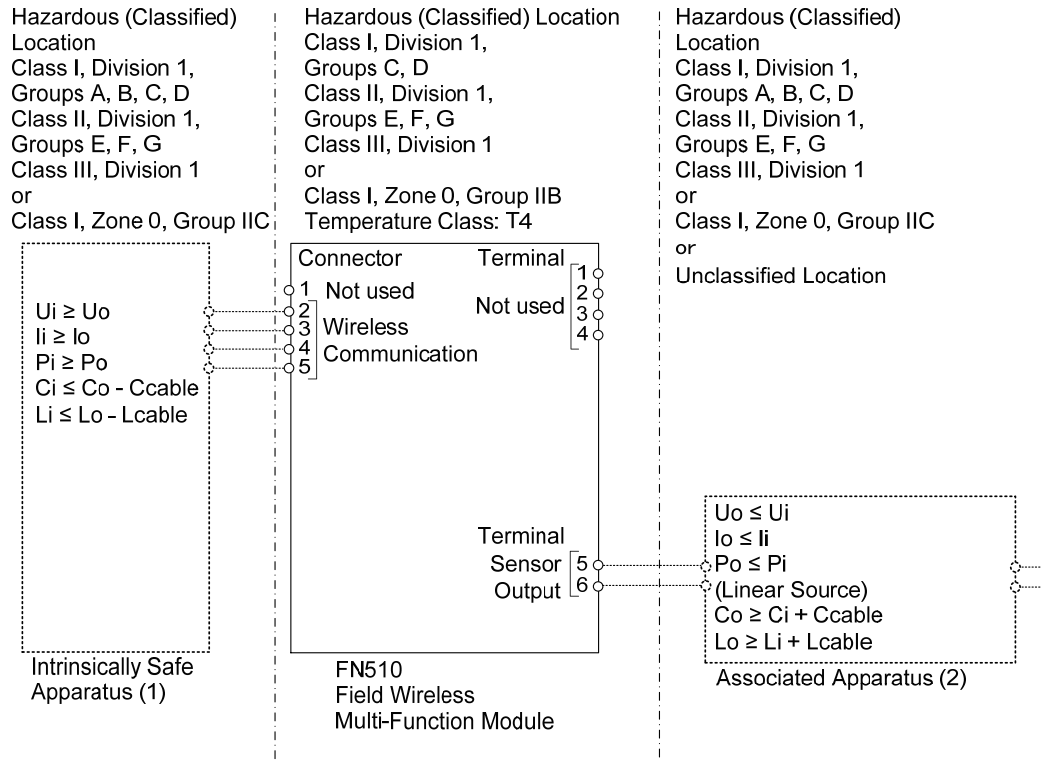

Wireless Communication (Connector)
 U_o : 5.88 V
 I_o : 483 mA
 P_o : 779 mW
 C_o : 5.82 μ F
 L_o : 25 μ H

Sensor Output (Terminal 5, 6)
 U_i : 30 V
 I_i : 200 mA
 P_i : 1 W
 C_i : 10 nF
 L_i : 0 μ H

Rev.

Doc. No. : IFM045-A81 P.3

Yokogawa Electric Corporation

Model: FN510 series

Date: May 29, 2015

PULSE

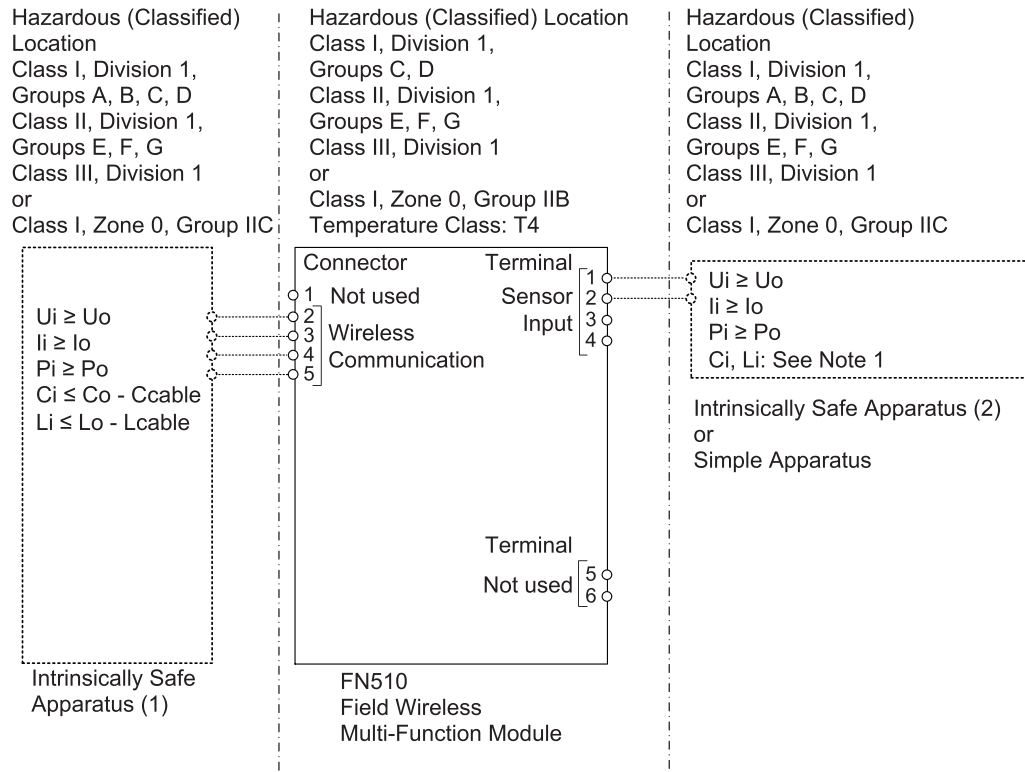

Wireless Communication (Connector)	
Uo :	5.88 V
Io :	483 mA
Po :	779 mW
Co :	5.82 μF
Lo :	25 μH

Sensor Input (Terminal 1 to 4)	
Uo :	5.88 V
Io :	145 mA
Po :	213 mW
Co :	43 μF
Lo :	1.6 mH

Specific Conditions of Use:

- Precautions shall be taken to minimize the risk from electrostatic discharge of non-metallic parts. When the equipment is used in hazardous locations, avoid any actions which generate electrostatic charges, such as rubbing with a dry cloth.
- The connector on the enclosure contains aluminum and is considered a potential risk of ignition caused by impact or friction. When the equipment is used in Zone 0, it must be installed such that, even in the event of rare incidents, ignition sources due to impact and/or friction sparks are excluded.
- Rigid type conduit shall not be used as the wiring method.

Rev.

Doc. No. : IFM045-A81 P.4

Yokogawa Electric Corporation

Model: FN510 series

Date: May 29, 2015

Notes:

1. As allowable connection values of an Intrinsically Safe Apparatus (2) or (3) and (4), the following conditions of (a) or (b) must be satisfied.
 (a) $\{(Li \times 100 \leq Lo) \text{ or } (Ci \times 100 \leq Co)\}$ and $\{Li \leq (Lo - Lcable) \text{ and } Ci \leq (Co - Ccable)\}$
 (b) $\{Li \leq (Lo / 2 - Lcable) \text{ and } Ci \leq (Co / 2 - Ccable)\}$ and
 $\{[(Ci + Ccable) \leq 600 \text{ nF for Group IIC}] \text{ or } [(Ci + Ccable) \leq 1\mu\text{F for Group IIA, IIB}]\}$
2. (For US) No revision to this drawing without prior approval of FM.
3. (For US) Installation must be in accordance with the National Electric Code (NFPA70), ANSI/ISA-RP12.06.01, and relevant local codes.
4. (For Canada) Installation must be in accordance with the Canadian Electrical Code Part I (C22.1), ANSI/ISA-RP12.06.01, and relevant local codes.
5. (For US) IS Apparatus (or Associated Apparatus) must be FM approved.
6. Control equipment connected to IS Apparatus (or Associated Apparatus) must not use or generate a voltage more than U_m of the control equipment.
7. The equipment satisfies the requirements for IP66 and Type 4X only when it is connected to a connector JR13WPI-5P (Hirose Electric) and tightened with a torque of 1.2-2.0 N·m. Appropriate type of plug must be used in accordance with the instructions.
8. The control drawing of IS Apparatus (or Associated Apparatus) must be followed when installing the equipment.
9. WARNING – POTENTIAL ELECTROSTATIC CHARGING HAZARD – WHEN THE EQUIPMENT IS USED IN HAZARDOUS LOCATIONS, AVOID ANY ACTIONS WHICH GENERATE ELECTROSTATIC CHARGES, SUCH AS RUBBING WITH A DRY CLOTH
10. WARNING – WHEN THE EQUIPMENT IS USED IN ZONE 0, IT MUST BE INSTALLED SUCH THAT, EVEN IN THE EVENT OF RARE INCIDENTS, IGNITION SOURCES DUE TO IMPACT AND FRICTION SPARKS ARE EXCLUDED
11. WARNING – TO PREVENT IGNITION OF FLAMMABLE OR COMBUSTIBLE ATMOSPHERES, READ, UNDERSTAND AND ADHERE TO THE MANUFACTURE'S LIVE MAINTENANCE PROCEDURE
12. WARNING – USE ONLY YOKOGAWA BATTERY PACK F9090FC or F9090GC
13. WARNING – THE BATTERY PACK CAN BE REPLACED IN A HAZARDOUS LOCATION. THE BATTERY PACK HAS SURFACE RESISTIVITY GREATER THAN 1G OHM AND MUST BE PROPERLY INSTALLED IN THE ENCLOSURE OF THE EQUIPMENT. CARE MUST BE TAKEN DURING TRANSPORTATION TO AND FROM THE POINT OF INSTALLATION TO PREVENT ELECTROSTATIC CHARGE BUILD-UP
14. WARNING – CELLS MUST BE CHANGED IN AN UNCLASSIFIED LOCATION ONLY
15. WARNING – SUBSTITUTION OF COMPONENTS MAY IMPAIR INTRINSIC SAFETY

Rev.

Doc. No. : IFM045-A81 P.5

Yokogawa Electric Corporation



WARNING / AVERTISSEMENT

- DANGER POTENTIEL DE CHARGES ÉLECTROSTATIQUES
 - QUAND LE MATÉRIEL EST UTILISÉ DANS DES ENDROITS DANGEREUX, ÉVITER TOUTE ACTION QUI GENERENT CHARGES ELECTROSTATIQUES, COMME FROTTANT AVEC UN CHIFFON SEC
- QUAND LE MATÉRIEL EST UTILISÉ DANS LA ZONE 0, IL DOIT ÊTRE INSTALLÉE TELLE QUE, MÊME EN CAS D'INCIDENTS RARE, SOURCES D'ALLUMAGE DUE AUX IMPACTS ET SPARKS FRICTION EST EXCLUE
- POUR ÉVITER ALLUMAGE DES ATMOSPHÈRES INFLAMMABLES OU COMBUSTIBLES, LISEZ, COMPRENDRE ET RESPECTER ELS PROCÉDURES D'ENTRETIEN DU CONSTRUCTEUR
- UTILISER UNIQUEMENT DES ACCUMULATEUR F9090FC OU F9090GC (YOKOGAWA)
- LA BATTERIE PEUT ÊTRE REMPLACÉ DANS DES ENDROITS DANGEREUX. BATTERIE POSSÈDE UNE RÉSISTANCE DE SURFACE QUI EST SUPÉRIEURE À 1 G OHM ET DOIT ÊTRE INSTALLÉ DANS L'ENVELOPPE DE L'ÉQUIPEMENT, SOIN PENDANT LE TRANSPORT ET DEPUIS LE POINT DE L'INSTALLATION POUR ÉVITER CHARGE ÉLECTROSTATIQUE BUILD-UP
- CELLULES DOIVENT ÊTRE CHANGÉ DANS UN ENDROIT UNCLASSIFIED SEULEMENT
- SUBSTITUTION DE COMPOSANTS PEUT IMPAIR LA SÉCURITÉ INTRINSÈQUE
- Be sure to use the specified battery pack and batteries. For details, refer to section 8.5 "Handling Batteries."
- With an intrinsically safe products, the battery pack is replaceable in a hazardous area. During the replacement work, make sure that dust and water droplets do not enter inside the products. For details on how to replace the battery pack, refer to section 8.3 "Replacing the Battery Pack."

2.6.3 ATEX Certification

(1) Technical Data

Caution for ATEX Intrinsically safe type.

Note 1. Model FN510 Field Wireless Multi-Function Module with optional code /KS27 for potentially explosive atmospheres:

- No. FM15ATEX0071X
- Applicable Standards: EN 60079-0:2012/A11:2013, EN 60079-11:2012, EN 60079-28:2015
- Type of Protection and Marking code: Ex ia op is [ia IIC] IIB T4 Ga
- Group: II
- Category: 1 G
- Amb. Temp.: -40 to 70°C (-40 to 158 °F)
- Enclosure: IP66 according to EN 60529:1991/A1:2000/A2:2013

Note 2. Electrical Parameters (Refer to the Control Drawing)

Note 3. Installation

- Installation should be in accordance with local installation requirements. (Refer to the Control Drawing)

[Control Drawing, IFM045-A84 for ATEX Certification]

- DIDO

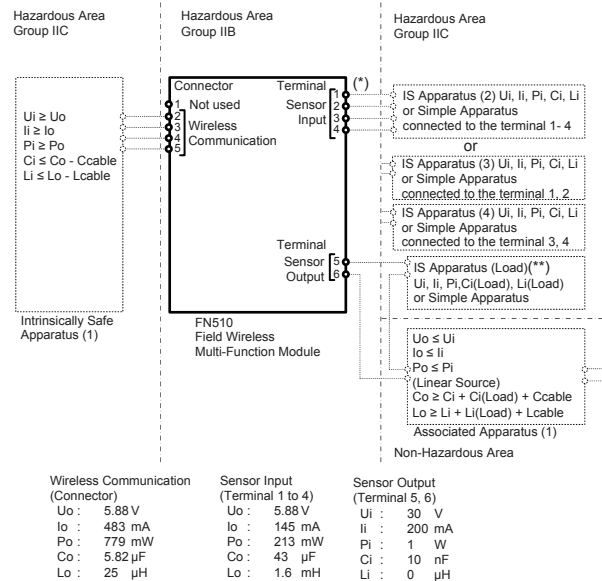

(*) If the Intrinsically Safe Apparatus are connected to Terminal 1- 4, entity parameters shall be satisfied as shown below:
 $U_i \geq U_o$, $I_i \geq I_o$, $P_i \geq P_o$, C_i , L_i : See *1

(**) "Load" is a solenoid valve, a relay coil, or a lamp.

• AI(1)

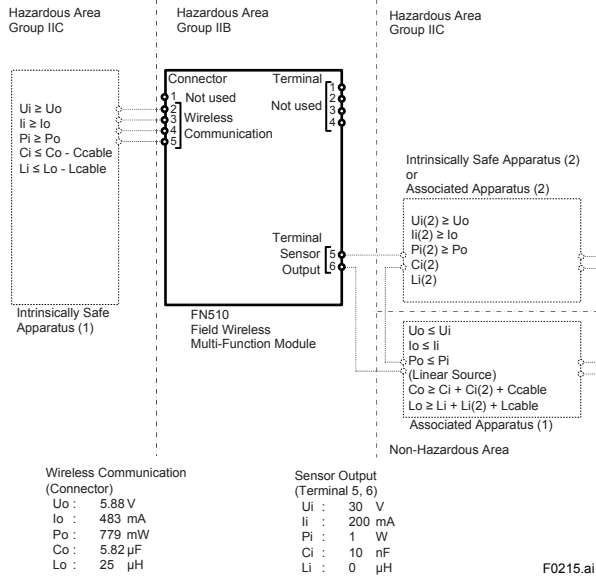

• AI(2)

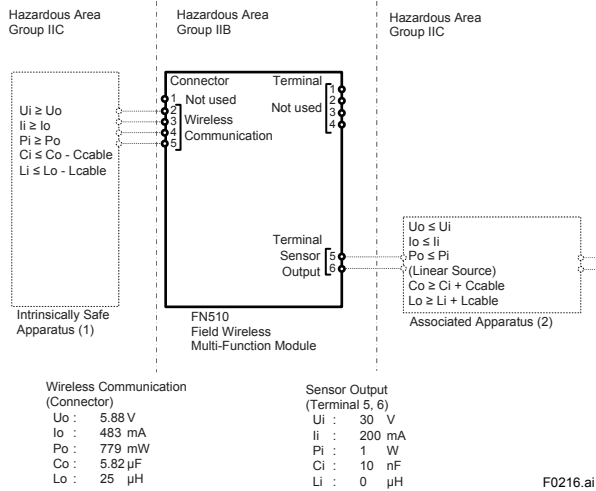

• Pulse

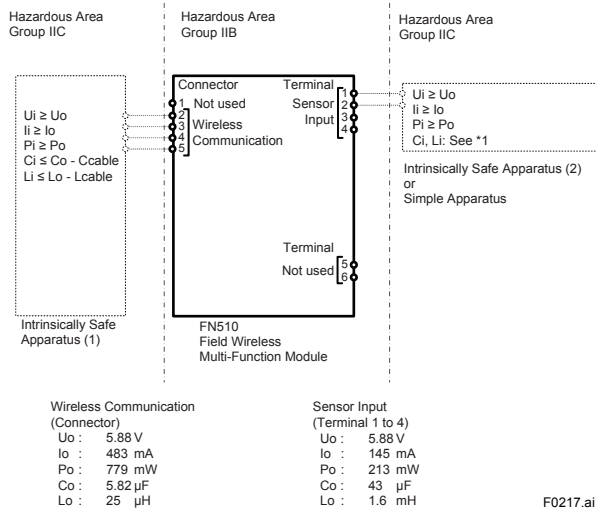

- *1 As allowable connection values of an Intrinsically Safe Apparatus (2) or (3) and (4), the following conditions of (a) or (b) must be satisfied.
- (a) $\{(Li \times 100 \leq Lo) \text{ or } (Ci \times 100 \leq Co)\}$ and $\{Li \leq (Lo - Lcable) \text{ and } Ci \leq (Co - Ccable)\}$
 - (b) $\{Li \leq (Lo / 2 - Lcable) \text{ and } Ci \leq (Co / 2 - Ccable)\}$ and $\{[(Ci + Ccable) \leq 600 \text{ nF for Group IIC}] \text{ or } [(Ci + Ccable) \leq 1\mu\text{F for Group IIA, IIB}]\}$

Note 4. Battery Pack

- Use only YOKOGAWA battery pack F9090FC or F9090GC.



WARNING

- Be sure to use the specified battery pack and batteries. For details, refer to section 8.5 "Handling Batteries."
- With an intrinsically safe Products, the battery pack is replaceable in a hazardous area. During the replacement work, make sure that dust and water droplets do not enter inside the Products. For details on how to replace the battery pack, refer to section 8.3 "Replacing the Battery Pack."

Note 5. Special conditions for Safe Use

- Precautions shall be taken to minimize the risk from electrostatic discharge of nonmetallic parts. When the equipment is used in hazardous locations, avoid any actions which generate electrostatic charges, such as rubbing with a dry cloth.
- The connector (FN110 terminal) on the enclosure contains aluminum and is considered a potential risk of ignition caused by impact or friction. When the connector is used in a potentially explosive atmosphere requiring equipment category 1 G, it must be installed such that, even in the event of rare incidents, ignition sources due to impact and/or friction sparks are excluded.

(2) Operation



WARNING

Take care not to generate mechanical sparking when access to the instrument and peripheral devices in a hazardous location.

(3) Maintenance and repair



The instrument modification or parts replacement by other than an authorized Representative of Yokogawa Electric Corporation is prohibited and will void the certification.

(4) Name Plate

- Name Plate

MODEL	FN510	SUFFIX	
STYLE			
S/N			
DATE		SUPPLY	----- VDC

Read IM 01W03E01-01
YOKOGAWA
 Yokogawa Electric Corporation
 TOKYO 180-8750 JAPAN
 Made in Japan

MSIP-REM-YHQ-EEN372
 172608

F0218.ai

- Name Plate for intrinsically safe type

0344 	II 1 G Ex ia op is [ia IIC] IIB T4 Ga -40°C ≤ Ta ≤ +70°C IP66 FM 15ATEX0071X INSTALL AS PER IFM045-A84	510A KS27
	<p>WARNING POTENTIAL ELECTROSTATIC CHARGING HAZARD - READ IM 01W03E01-01 USE ONLY BATTERY PACK F9090FC OR F9090GC (YOKOGAWA)</p>	

F0219.ai

2.6.4 IECEx Certification

(1) Technical Data

Caution for IECEx Intrinsically safe type.

Note 1. Model FN510 Field Wireless Multi-Function Module with optional code /SS27 for potentially explosive atmospheres:

- No.: IECEx FMG 15.0042X
- Applicable Standards:
IEC 60079-0:2011, IEC 60079-11:2011, IEC 60079-28:2015,
- Type of Protection and Marking code:
Ex ia op is [ia IIC] IIB T4 Ga
- Enclosure: IP66 according to IEC60529:2013
- Ambient Temperature: -40 to 70 °C (-40 to 158 °F)

Note 2. Electrical Parameters
(Refer to the Control Drawing)

Note 3. Installation

- Installation should be in accordance with local installation requirements.
(Refer to the Control Drawing)

[Control Drawing, IFM045-A84 for IECEx Certification]

- DIDO

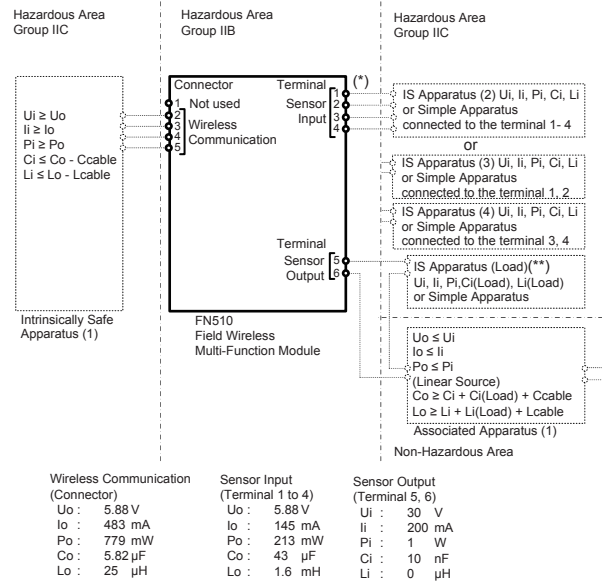

(*) If the Intrinsically Safe Apparatus are connected to Terminal 1- 4, entity parameters shall be satisfied as shown below:

Ui ≥ Uo, Ii ≥ Ii, Pi ≥ Po, Ci, Li: See *1

(**) "Load" is a solenoid valve, a relay coil, or a lamp.

F0220.ai

- AI(1)

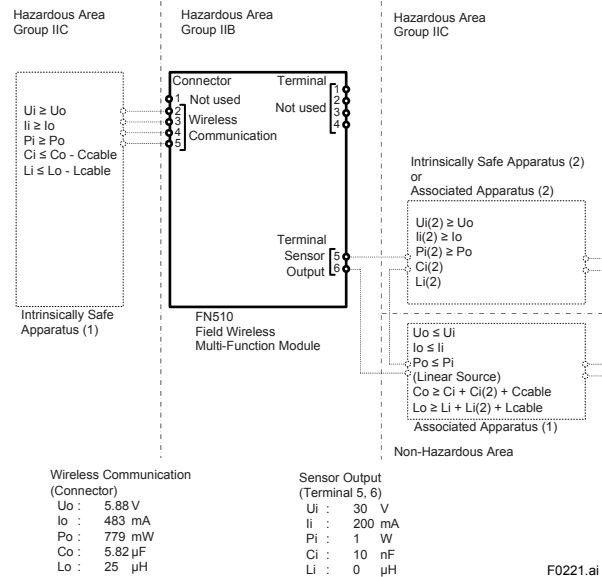

F0221.ai

• AI(2)

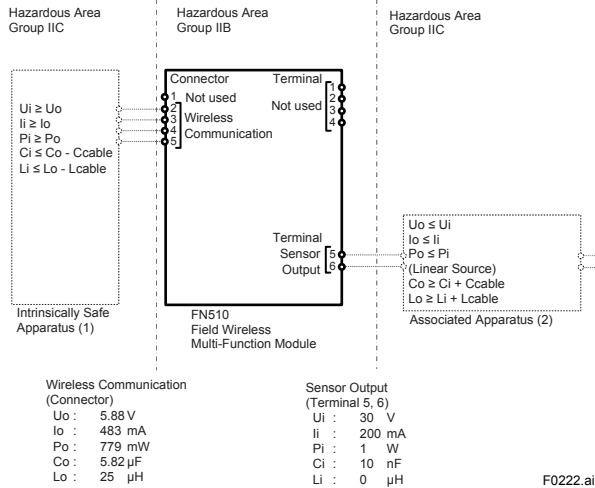

• Pulse

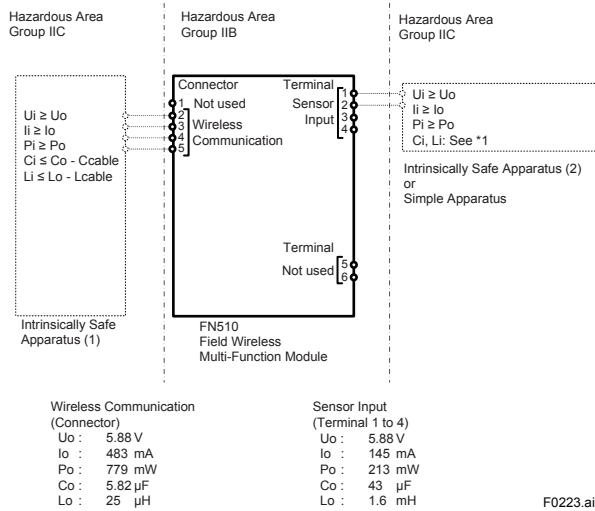

- *1 As allowable connection values of an Intrinsic Safe Apparatus (2) or (3) and (4), the following conditions of (a) or (b) must be satisfied.
- (a) $\{(Li \times 100 \leq Lo) \text{ or } (Ci \times 100 \leq Co)\}$ and $\{Li \leq (Lo - Lcable) \text{ and } Ci \leq (Co - Ccable)\}$
 - (b) $\{Li \leq (Lo / 2 - Lcable) \text{ and } Ci \leq (Co / 2 - Ccable)\}$ and $\{(Ci + Ccable) \leq 600 \text{ nF for Group IIC}\}$ or $\{(Ci + Ccable) \leq 1 \mu\text{F for Group IIA, IIB}\}$

Note 4. Battery Pack

- Use only YOKOGAWA battery pack F9090FC or F9090GC.



- Be sure to use the specified battery pack and batteries. For details, refer to section 8.5 "Handling Batteries."
- With an intrinsically safe products, the battery pack is replaceable in a hazardous area. During the replacement work, make sure that dust and water droplets do not enter inside the products. For details on how to replace the battery pack, refer to section 8.3 "Replacing the Battery Pack."

Note 5. Special conditions for Safe Use

- Precautions shall be taken to minimize the risk from electrostatic discharge of nonmetallic parts. When the equipment is used in hazardous locations, avoid any actions which generate electrostatic charges, such as rubbing with a dry cloth.
- The connector (FN110 terminal) on the enclosure contains aluminum and is considered a potential risk of ignition caused by impact or friction. When the connector is used in a potentially explosive atmosphere requiring EPL Ga, it must be installed such that, even in the event of rare incidents, ignition sources due to impact and/or friction sparks are excluded.

(2) Operation



Take care not to generate mechanical sparking when access to the instrument and peripheral devices in a hazardous location.

(3) Maintenance and repair



The instrument modification or parts replacement by other than an authorized representative of Yokogawa Electric Corporation is prohibited and will void the certification.

2.7 EMC Conformity Standards

EN61326-1 Class A Table 2, EN55011 Class A



This instrument is a Class A product, and it is designed for use in the industrial environment. Please use this instrument in the industrial environment only.

3. Component Names

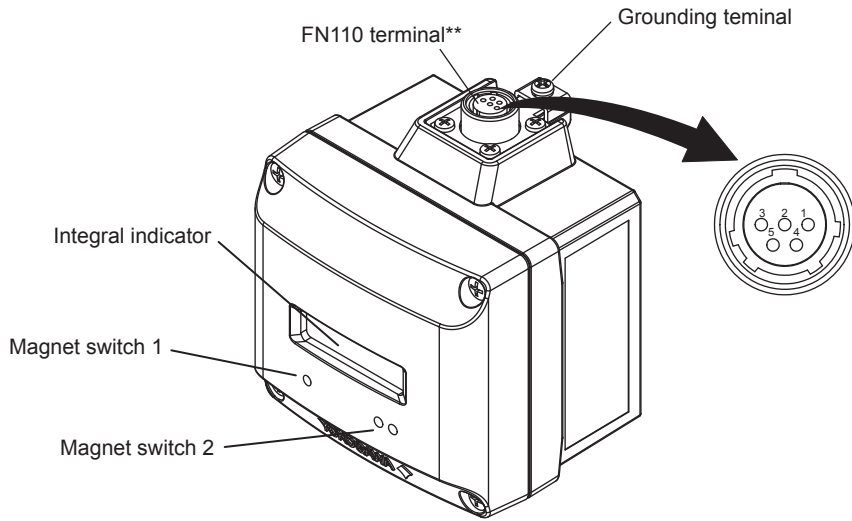

Pin	Signal
1	Frame Ground *
2	Signal Ground
3	Power Supply
4	Transmit/Receive Data positive
5	Transmit/Receive Data negative

* Wired to the grounding terminal inside the FN510 housing.
 ** Connector type of FN510: JR13WRI-5S (connector mating with type of JR13WPI-5P)

F0301.ai

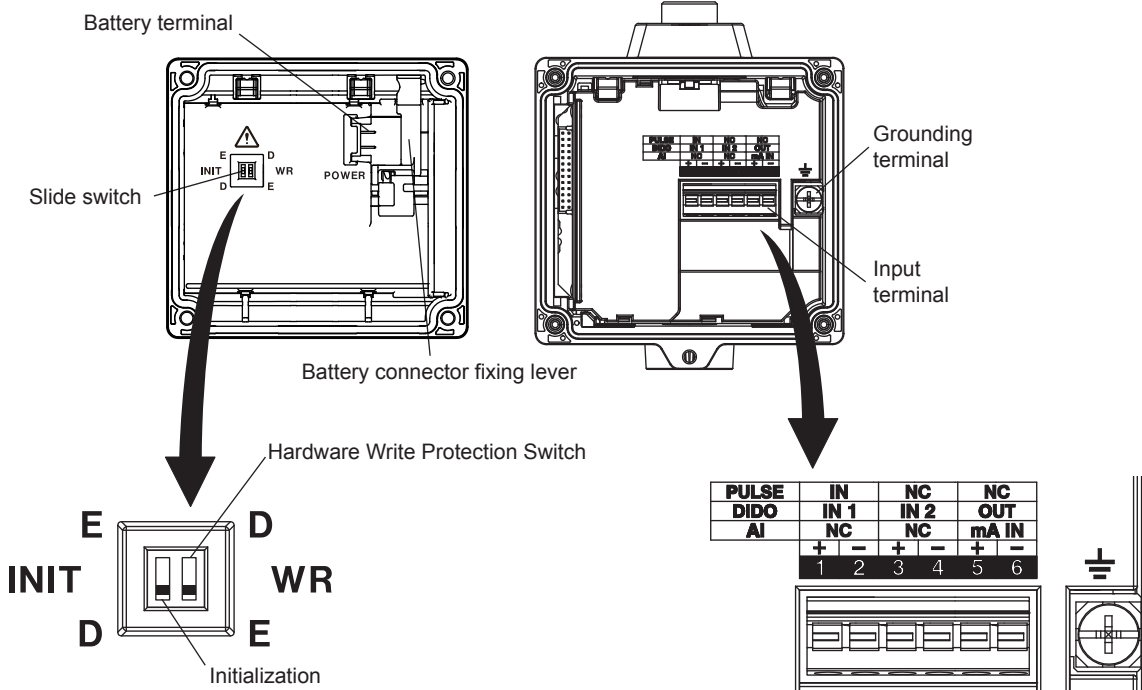

F0302.ai

Hardware Write Protection Switch (WR)		
Write Protection Switch Position *1		
Write Protection	No (Write enabled)	Yes *2 (Write disabled)

*1: Initialization switch is not used. Set to D side (disabled) always.
 *2: When the switch is D side (write protection setting), provisioning is acceptable. For details of provisioning, refer to subsection 6.3 "Connecting to the Field Wireless Network".

Terminal	Signal		
	AI	DIDO	PULSE
1	No Connection	Input Signal1 +	Input Signal +
2	No Connection	Input Signal1 -	Input Signal -
3	No Connection	Input Signal2 +	No Connection
4	No Connection	Input Signal2 -	No Connection
5	Input Signal +	Output Signal +	No Connection
6	Input Signal -	Output Signal -	No Connection
⏏	Frame Ground		

4. Installation

4.1 Precautions

- Before installing FN510, read the cautionary notes in subsection 2.4 “Selecting the Installation Location”.
- For additional information on the ambient conditions allowed at the installation location, refer to subsection 10.1 “Standard Specifications”.



IMPORTANT

Connector Protection

The FN110 terminal is covered with a cap during shipping. Keep the cap attached until connecting the FN110 or remote antenna cable to protect the inside connection part. The unscrewed cap should be stored in order to replace it immediately after the FN110 or remote antenna cable is removed. If there is a possibility that get wet with water, order FN510 with optional specification for a protection cap.

Installation Work

- When performing on-site pipe fitting work that involves welding, use case to prevent the welding current to damage the FN510.
- Do not use the FN510 as a foothold.



NOTE

- Before using FN510, install FN110. For detail on how to install FN110, refer to subsection 4.2.1 “Installation of FN110”.
- To connect FN510 to the field wireless network, information for connecting to the field wireless devices needs to be set beforehand. Refer to subsection 6.3 “Connecting to the Field Wireless Network”.

4.2 Mounting

FN510 is installed on a 50A (2-inch) pipe with mounting bracket. Refer to subsection 4.2.2 “Mounting of FN510” for details. For detail on how to install FN110, refer to subsection 4.2.1 “Installation of FN110”. For using remote antenna cable, refer to subsection 5.3 “Installation and Connection of FN110”.

4.2.1 Installation of FN110

Install FN110 to the FN110 terminal of FN510. Before installation, remove the unscrewed cap attached to the connector and remove the battery pack from FN510.

The installation procedure is as follows.

1. Check the direction of the pin, connect FN110 to FN510.
 2. Tighten the lock nut to torque of 1.2 N•m.
- Removal is the reverse procedure of the installation.

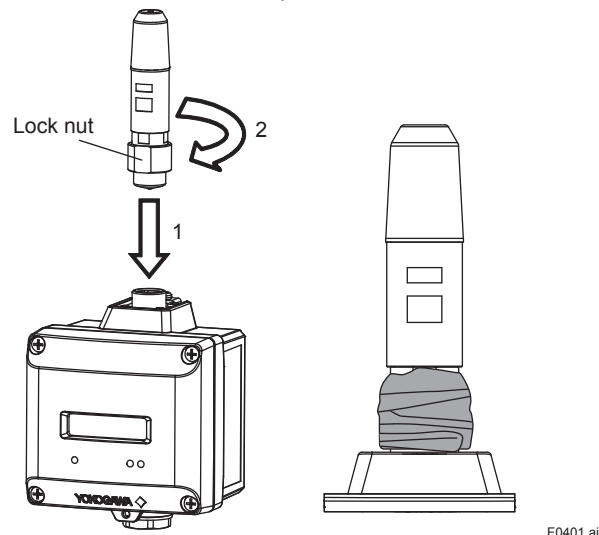

Figure 4.1 Installation of FN110 and Sealing of the Connector

CAUTION

- To maintain a good connection between the modules, protect the connector from the corrosive atmosphere by the following treatment.
 1. Clean the connection to be protected.
 2. Wind the butyl rubber self-bonding tape around the connection. See the manual of the tape about the winding.
 3. To protect the butyl rubber self-bonding tape from the environment such as ultraviolet rays and so on, wind vinyl tape (or a vinyl type self-bonding tape) on it.
 4. When the tape is necessary, prepare appropriate tape for the installing environment.

Do not cover the nameplate by the tapes.

- When a remote antenna cable is used for installing FN110, refer to subsection 5.3 “Installation and Connection of FN110”.
- Remove the battery pack before installing FN110. Refer to subsection 8.3 “Replacing the Battery Pack” for the battery pack removing.
- When installing FN110, fix the FN110 by tightening the lock nut. Screwing by holding the FN110 housing may cause failure such as cable disconnection. The same manner should be taken when removing the FN110.

4.2.2 Mounting of FN510

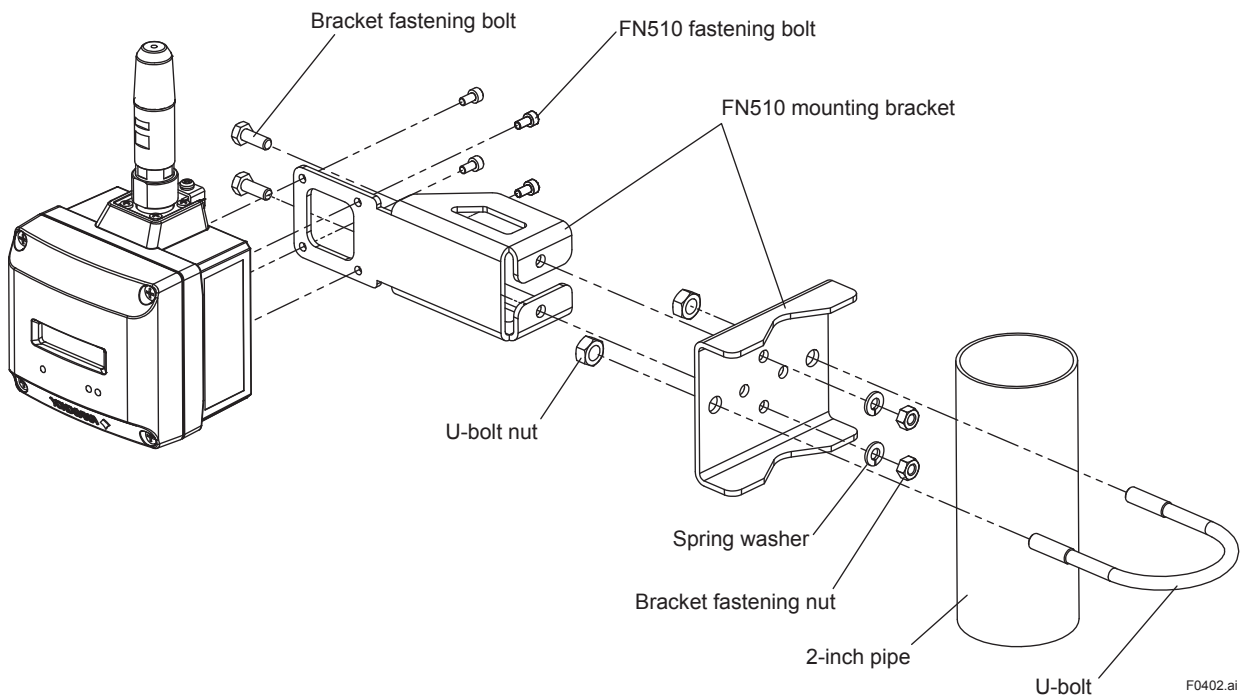
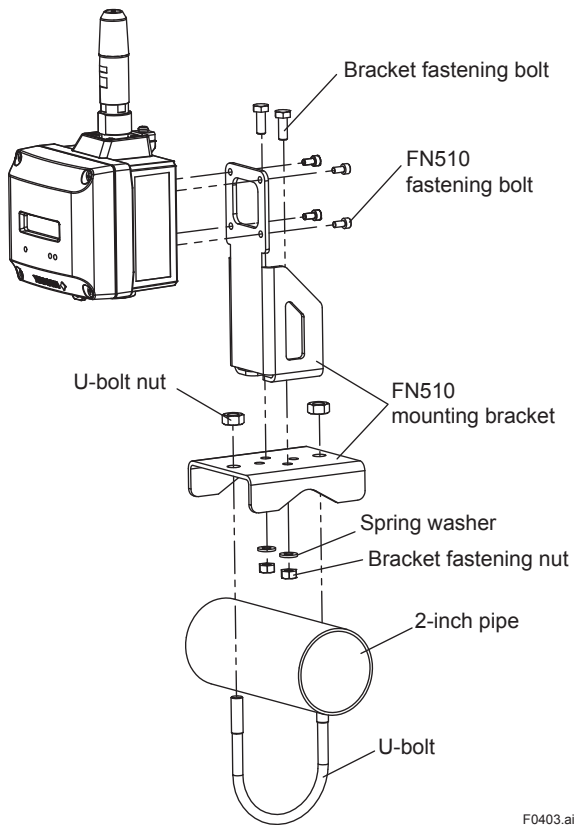

Figure 4.2 Vertical Pipe Mounting



F0403.ai

Figure 4.3 Horizontal Pipe Mounting

■ **To install FN510 on a 50A (2-inch) pipe, follow the procedure below.**

- 1) Assemble the FN510 mounting bracket.
- 2) Install FN510 to the mounting bracket using provided bolt (4) with a torque 1.4 N•m.
- 3) Install FN510 mounting bracket to the 2-inch pipe by U-bolt.

5. Wiring

5.1 Notes on Wiring



IMPORTANT

- Apply a waterproofing sealant to the threads of the connection port. (It is recommended that you use non-hardening sealant made of silicon resin for waterproofing.)
- Lay wiring as far away as possible from electrical noise sources such as large transformers, motors and power supplies.
- Remove the wiring connection dust-caps before wiring.
- When you open the front panel, pay great attention to the environmental conditions in order to prevent dust and water droplets entering inside the product.
- To run wiring to the sensor, pay sufficient attention to the wiring parameters described in section 2.6 “Installation of an Explosion Protected Instrument.”
- To prevent electrical noise, the signal cable and the power cable must not be housed in the same conduit.



NOTE

- When wiring where the ambient temperature is high or low, use the cable or wire that appropriate to that place.
- When the maximum operating temperature is more than 60°C, use the cable of 85°C or higher temperature rating.

5.2 Cable Selection

For wiring the sensor and the FN510, use a shielded multi-core cable of AWG22 to 14.

■ Applicable Cables

Cables for industrial equipment such as;

- Control cables: JIS C 3401

Use the following grounding cable.

■ Applicable Cables

Insulated cables for industrial equipment such as;

- 600V polyvinyl chloride insulated wires (IV); JIS C3307
- Polyvinyl chloride insulated wires for electrical apparatus (KIV); JIS C3316
- 600V grade heat-resistant polyvinyl chloride insulated wires (HIV); JIS C3317
- Heatproof vinyl insulated wires VW-1 (UL1015/UL1007) Wire size
- Core: AWG14 to 13 (2mm² to 2.6mm²)

Termination

- Use a ring tongue terminal for M4 terminals: with an insulation sleeve

5.3 Installation and Connection of FN110



IMPORTANT

The FN110 terminal is covered with a cap at the time of delivery. Keep the cap attached until connecting the FN110 or remote antenna cable to protect the inside connection part. The unscrewed cap should be stored in order to replace it immediately after the FN110 or remote antenna cable is removed. If there is a possibility that get wet with water, order FN510 with optional specification for a protection cap.

5.3.1 Installation of FN110

■ Location of FN110

Mount the FN110 at the proper location according to the wireless environment described in subsection 2.4 “Selecting the Installation Location”. The mounting to the pipe such as 50A (2-inch) pipe needs to secure the enough strength to endure a strong wind, vibration and so on. The FN110 must be mounted vertically.

■ Fixing of FN110

Fix the FN110 on a 50A (2-inch) pipe with the mounting bracket provided as the remote antenna cable option.

■ To install FN110 with mounting bracket, follow the procedure below.

- 1) Assemble the mounting bracket and fix it on a 50A (2-inch) pipe.
- 2) Connect the remote antenna cable to the FN110.
- 3) Protect the connection as necessary. For details of the protection, refer to subsection 4.2.1 “Installation of FN110”.
- 4) Fix the FN110 to the mounting bracket.

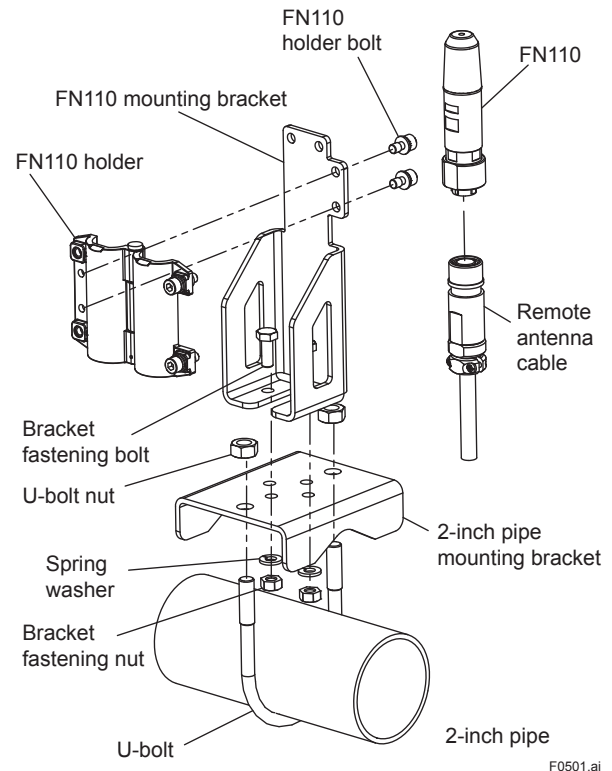

F0501.ai

Figure 5.1 Horizontal Pipe Mounting of FN110

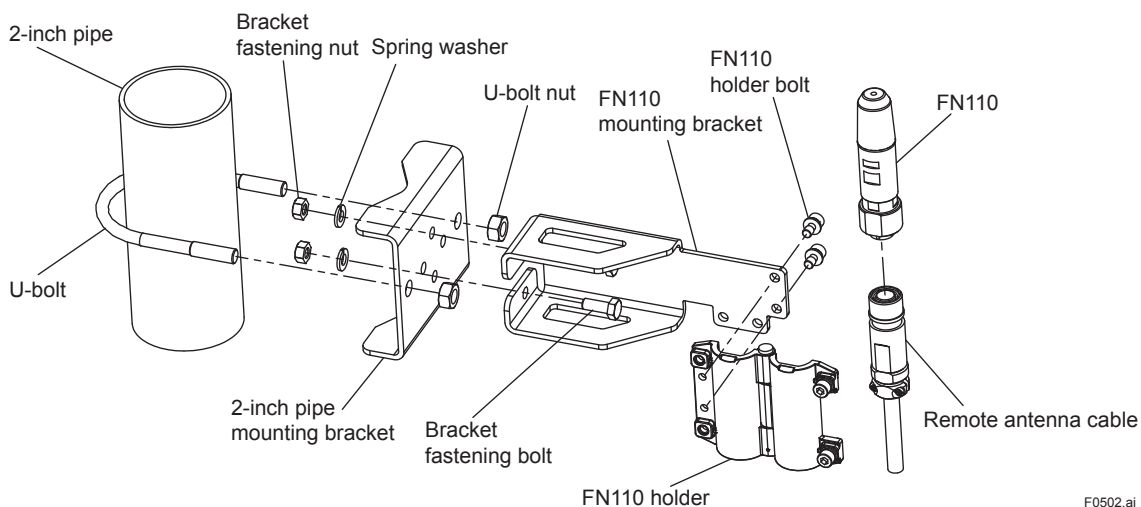

F0502.ai

Figure 5.2 Vertical Pipe Mounting of FN110

5.3.2 Connection of FN110

■ To install FN110 with remote antenna cable, follow the procedure below.

Remove the battery pack from FN510 before connecting the remote antenna cable.

1. Connect the FN110 and the FN510 with the dedicated remote antenna cable. Tighten the connector of the remote antenna cable with a torque of 1 to 1.2 N•m. The minimum bending radius should be more than 100 mm.
2. Protect the connectors of the FN110 and remote antenna cable as necessary. For details of the protection, refer to subsection 4.2.1 “Installation of FN110”.
3. Fix the remote antenna cable to an appropriate structure to protect the cable from the vibration, wind, and so on. The minimum bending radius for fixing in the state maintained for a long period should be more than 100 mm.

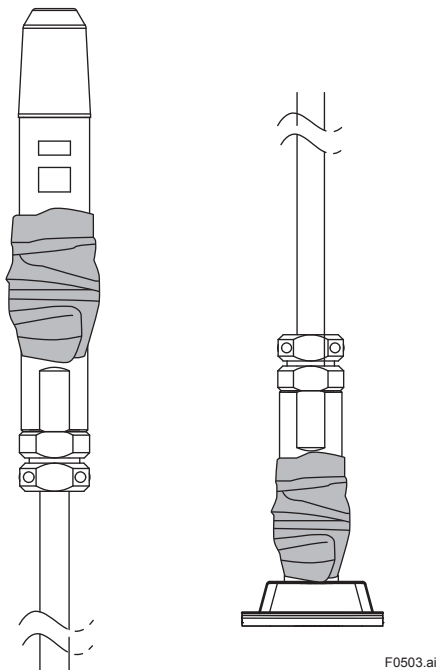

Figure 5.3 Sealing of the Remote Antenna Cable

CAUTION

- Use the dedicated remote antenna cable provided by Yokogawa as accessories for FN110.
- The remote antenna cable and other cables should not be bundled together.
- Remove the battery pack before installing FN110. Refer to subsection 8.3 “Replacing the Battery Pack” for the battery pack removing.

5.4 Connecting Input Signal Cable

Strip the insulated cover of the cable end.

5.4.1 Connecting Input Terminal and Grounding Terminal

■ Vertical Connection

After stripping the insulated cover, keep a length of about 50mm for input signal cables, and about 65mm for grounding cable.

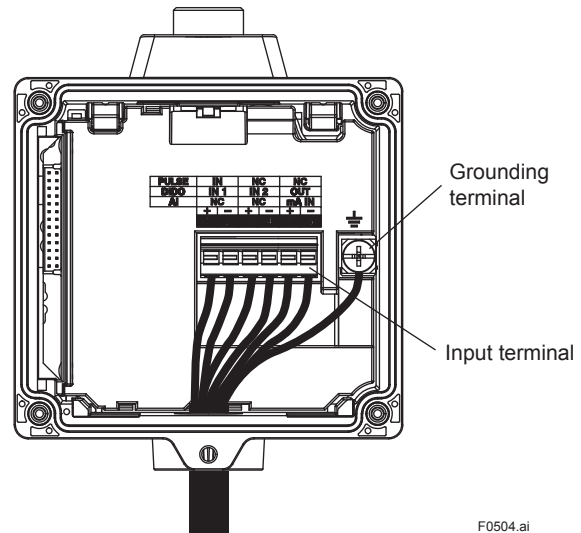

Figure 5.4 Connection example when using DIDO Function

The cable gland is not included. Prepare a cable gland with a flat gasket matching the electrical connection.

When M20 female is selected for vertical connection, tighten the cable gland with a torque of 2 N•m. When G 1/2 female or 1/2 NPT female is selected for vertical connection, fix the hexagonal shape part by tool and tighten the cable gland as shown in Figure 5.5.

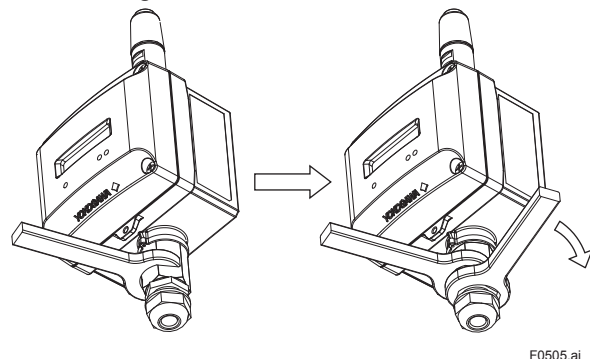

Figure 5.5 Tightening the Cable Gland



IMPORTANT

When using a cable gland, apply a water proofing sealant to the threads of the cable gland. (It is recommended that you use non-hardening sealant made of silicon resin for waterproofing.)

Input Terminal

Input terminal is a spring terminal. When using a solid conductor cable or with sleeve, connect the cable to the input terminal. When using a standard conductor, push down the top of a cable inlet and insert the cable. To unplug the cable, push down the top of a cable inlet and unplug the cable.

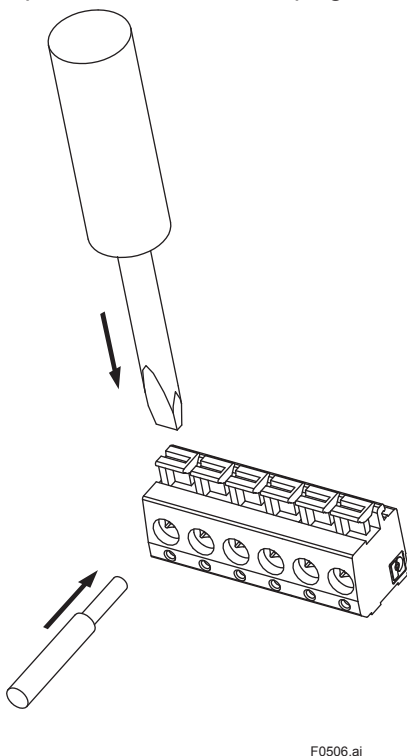

F0506.ai

Figure 5.6 Connecting to the Input Terminal

Wiring to Input Terminals:1 (with sleeve)

The sleeve can prevent cable leads from untwist when you connect the cable. Select a sleeve to match the cable size. If the length of cable leads does not match the length of sleeve (l_2), strip the cable to the correct length. Strip the cable for a length so that the core wire slightly extends from the metal tube of the sleeve. If this causes the length of the metal tube of the sleeve to be slightly shorter than the stripping length, this is no problem.

The wiring cables and applicable sleeves are listed in the table below. Use the same manufacturer for sleeves and tools.

Example of tool: Phoenix Contact's CRIMPFOX6
For details on sleeves and crimp tools, contact to Phoenix Contact Inc.

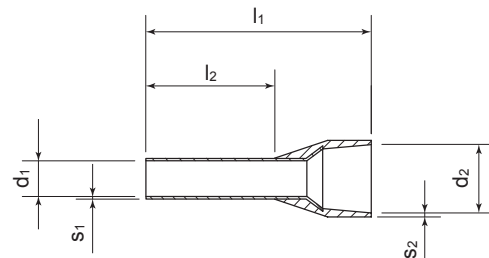

F0507.ai

Figure 5.7 Sleeve Length

Wiring to Input Terminals:2 (without sleeve)

- When using a solid conductor cable, strip the insulated cover and connect it. Strip the insulated cover for 8mm.
- When using a stranded conductor, strip the insulated cover and twist and connect it. Strip the insulated cover for 8mm. Never solder the stranded conductor when connecting cables. Be careful not to cause the loosely stranded conductor to come in contact with adjacent terminals or others. Insert the cable leads into the terminal block securely.

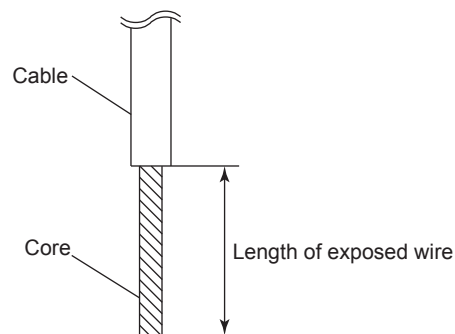

F0508.ai

Figure 5.8 Length of Exposed Wire

Table 5.1 Corresponding Sleeve and Input Cables

Cable		Dimensions (mm)						Phoenix Contact's type
AWG	Strip length (mm)	l ₁	l ₂	d ₁	S ₁	d ₂	S ₂	
24	8	10.5	6	0.8	0.15	2	0.25	AI 0.25-6 BU
22	8	12.5	8	0.8	0.15	2	0.25	AI 0.34-8 TQ
20	8	14	8	1.1	0.15	2.5	0.25	AI 0.5-8 WH
18	8	14	8	1.3	0.15	2.8	0.25	AI 0.75-8 GY
18	8	14	8	1.5	0.15	3	0.3	AI 1-8 RD
16	8	14	8	1.8	0.15	3.4	0.3	AI 1.5-8 BK
14	8	14	8	2.3	0.15	4.2	0.3	AI 2.5-8 BU

Connect external device as Figure 5.9.

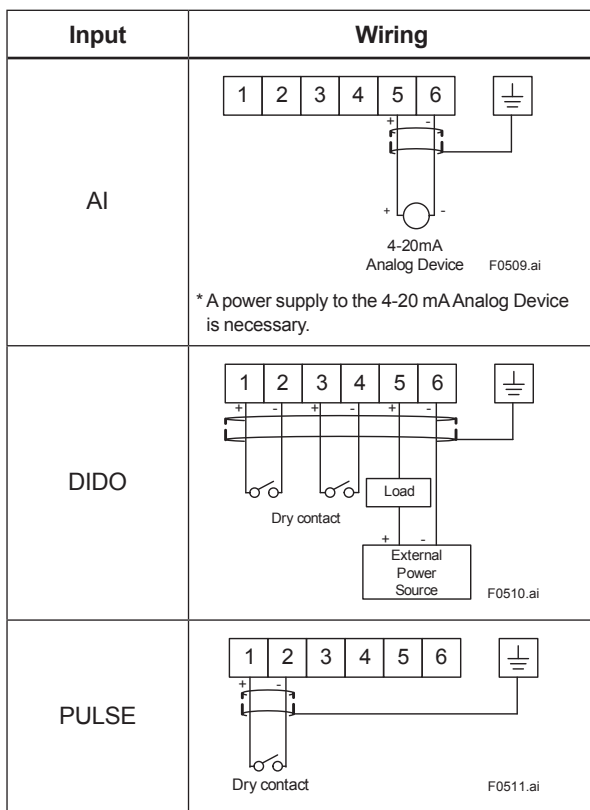

Figure 5.9 Input Terminal Wire Connection Diagram



IMPORTANT

- Do not apply external voltage to the DI, DO and PULSE terminals.
- The DO output is an open drain output. Ensure that the applied current or voltage to the DO terminals is within the specification range.



CAUTION

- Remove the battery pack before wiring. Refer to subsection 8.3 “Replacing the Battery Pack” for the battery pack removing.
- Connect the devices to the correct terminals. Operating with incorrect connection may cause damage to FN510 or connected devices.



NOTE

Strip the insulated cover of the input cable inside the FN510 so as not to interfere with the battery pack.

■ **Wiring to Ground Terminal**

Protect the cable of the ground terminal by using heat-shrink tubing, etc. Use a ring tongue terminal for M4 terminals with an insulation sleeve.

5.5 Grounding

Class D grounding with the grounding resistance of 100Ω or less is necessary. To connect the grounding cable to FN510 directly, use the ground terminal on the top of the housing.

Do not share the ground wiring with other devices.

■ Ground Wiring

Connect the grounding cable to ground terminal on the top of the housing.

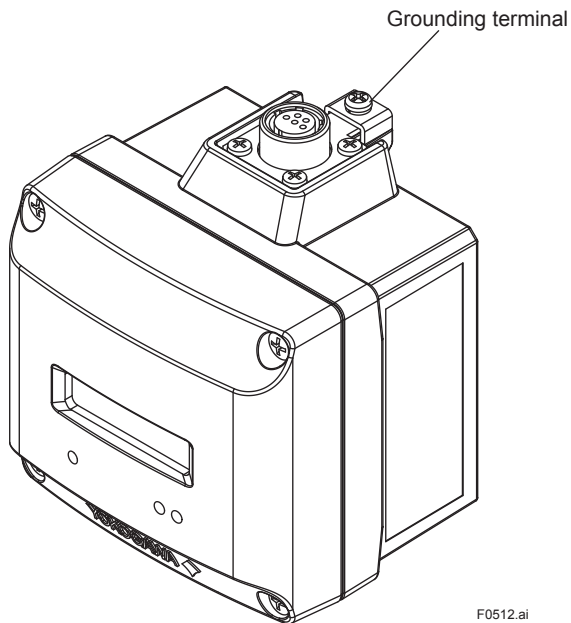

F0512.ai

Figure 5.10 Grounding Terminal



CAUTION

Grounding is required for safe operation.

■ Input Cable Wiring

The input cable shield should be connected to grounding terminal inside of the housing.

- The input cable shield should not be connected to grounding terminal inside of the connected sensor.
- Connection to the ground terminal of the connected device housing, refer to the User's Manual.

6. Operation

6.1 Preparation for Starting Operation



NOTE

- Before using FN510, connect FN110. For detail on how to install the FN110, refer to subsection 4.2.1 “Installation of FN110”.
- It is required to set security and network information to enable this product to be connected to the field wireless network. For more details, refer to subsection 6.3 “Connecting to the Field Wireless Network”.

(1) Checking Installation and Wiring

Ensure that the FN510, FN110 and the connected device are installed correctly according to the procedures described in section 4 “Installation”, and section 5 “Wiring”.

(2) Power On and Connecting to the Field Wireless Network

Insert batteries into the battery case, and install to the FN510. For details of installation of battery, refer to subsection 8.3 “Replacing the Battery Pack” and subsection 8.4 “Replacing the Batteries”. Provisioning is to set the security and network information. For details of provisioning, refer to section 6.3 “Connecting to the Field Wireless Network”.

(3) Checking the parameter of the FN510

Use the device configuration tool and confirm that the connected device and the FN510 operate properly. Check parameter values or change the setpoints as necessary.



IMPORTANT

Use the device configuration tool and confirm that the Sensor Type parameter setting in TRANCEDUCER block matches the input wiring. If the parameter is not properly set, change the parameter to match the input type. After changing the parameter, FN510 will restart automatically.

The integral indicator can be used to confirm that this product is operating properly. For details on how to confirm this, refer to subsection 7.4 “Self-Diagnostics”.

ISA100 devices display self-diagnostic information in an easy-to-understand manner using four categories (Function check, Maintenance required, Failure, and Out of specification) according to NAMUR NE107*

* NAMUR NE107 “Self-Monitoring and Diagnosis of Field Devices”

■ Confirm operation status by integral indicator

If the FN510 is faulty, an error code is displayed.

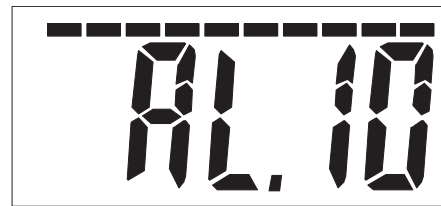

F0601.ai

Figure 6.1 Integral Indicator with Error Code



NOTE

If any of the above errors are indicated on the display of the integral indicator or the device configuration tool, refer to subsection 8.10.3 “Errors and Countermeasures” for the corrective action.

■ Verify and Change the FN510 Setting and Values

The followings are the required settings of the FN510. These parameters must be set before starting operation.

- TRANSDUCER block:Sensor Type
Select from DIDO, DI Pulse Count, 4-20 mA or “Not Used” the type of the device to be connected to FN510. Connect the device to the proper terminals of FN510 depending on the selection.
Select “Not Used” when using as a routing device without the connected device.

6.2 Starting Operation

Ensure that the installation, the wiring, the network connection, and the behavior of the FN510 are correct before starting operation.



IMPORTANT

Close the front panel. Tighten each screws to a torque of 0.7 N•m.

6.3 Connecting to the Field Wireless Network

■ Preparation Work Prior to Connecting to a Field Wireless Network

FN510 does not need to be connected with a physical wire. Instead of physical wiring, to set security and field network information is required. This procedure is called a provisioning. FN510 supports provisioning via infrared communication using a provisioning device and can be securely connected to a network. If the provisioning information is not set, the FN510 cannot be connected to the field wireless network.



NOTE

Before provisioning, connect the FN110. For detail on how to install the FN110, refer to subsection 4.2.1 “Installation of FN110”.

For details on provisioning using a provisioning device, connecting to a field wireless network and the setting procedure, refer to the User’s Manual, FieldMate Versatile Device Management Wizard (IM 01R01A01-01E), YFGW710 Field Wireless Integrated Gateway (IM 01W01F01-01EN), and YFGW410 Field Wireless Management Station (IM 01W02D01-01EN).

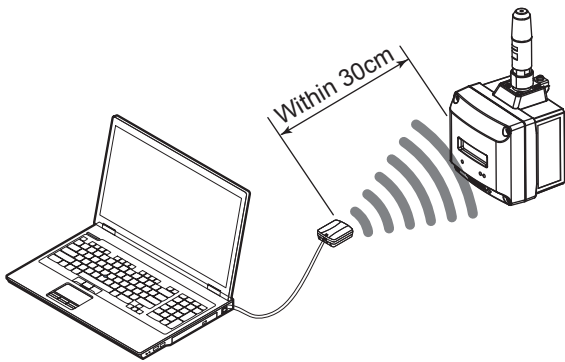

F0602.ai

Figure 6.2 Provisioning Example

■ Provisioning Work

This subsection describes provisioning work using FieldMate as the provisioning device.

Provisioning work performs provisioning for each field wireless device using FieldMate and an infrared adapter.

When using the Yokogawa recommended near infrared adapter for the provisioning device, the distance between the front panel of this product and the infrared surface of the near infrared adapter should be within 30 cm. For details on the Yokogawa recommended infrared adapter, refer to subsection 8.2 “Recommended Products List”.

Perform the following provisioning tasks.

- Setting provisioning information
- Creating a provisioning information file

(1) Setting provisioning information

Set the device tag and Network ID using a FieldMate provisioning function. The device tag, Network ID, and join key are set in the field wireless device. It is not necessary to input a join key because FieldMate automatically generates it.

- Setting device tag
 - The device tag is used for the user to recognize the field wireless device.
- Setting Network ID
 - This is the Network ID for the field wireless network to which the field wireless device is connected. Set a value from 2 to 65535.

The field wireless device is connected to the field wireless network corresponding to the Network ID set by provisioning work.

(2) Creating a provisioning information file

The following provisioned information is stored in the provisioning information file.

- Network ID
- Device tag
- EUI64
- Join key
- Provisioner (name of the user who performed provisioning work by Field Mate)
- Date (Time and date when provisioning was performed by FieldMate)

This provisioning information file is required to load from the field wireless configurator to the field wireless integrated gateway. Store the file carefully.

■ Connecting to a Field Wireless Network

The action after installing the battery pack varies depending on the silence setting. Mounting the battery pack automatically starts a search for the field wireless network and the device goes into the join state when the field wireless gateway is found. If the field wireless gateway is not found and a specified time based on the silence mode has elapsed, a cycle of 18-minute pause and 36-second search is repeated until the device can join the field wireless network. For details on the silence setting, refer to subsection 7.3.10 “Switching to the Silence Mode”.

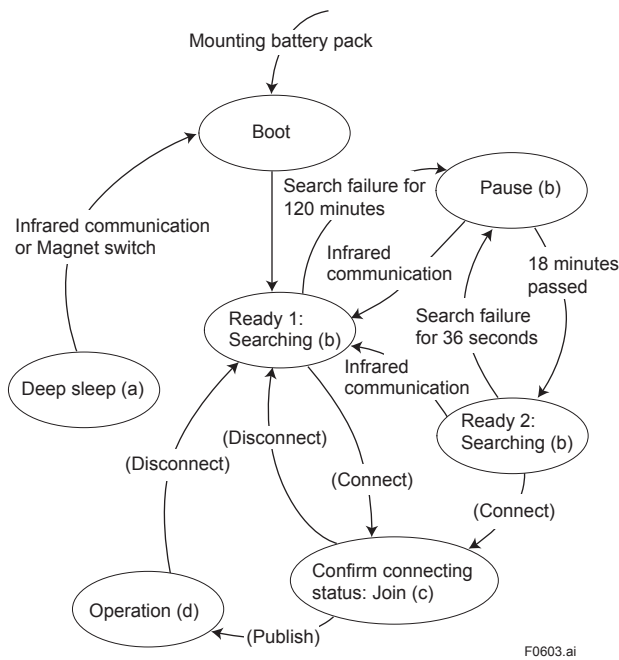

* By using a magnet switch or field device configuration tool, transitions to the Deep sleep state from any state.

Figure 6.3 Wireless Status Transition

(a) Deep Sleep



Figure 6.4 Display showing Deep Sleep State

Displays for 2 seconds in deep sleep setting, and then turns off.

(b) Ready and Pause



Figure 6.5 Display showing Ready and Pause State

(c) Confirm Connecting Status



Figure 6.6 Display showing Confirm Connecting Status State

(d) Join



Figure 6.7 Display showing Join State



NOTE

If the FN510 searches the field wireless network for long time low ambient temperature condition, sometimes error “AL.20 LOWBAT” is displayed on the integral indicator. It occurs because of battery characteristics even when using new batteries. After joining to the field wireless network, this error will be cleared within one hour if battery has no failure.

6.4 Display Contents of the Integral Indicator

■ Write Protect Status



When the write protection is enabled, the lock icon is displayed in the upper left corner of the integral indicator. For details on how to enable write protection, refer to subsection 7.3.8 “Write Protect”.

■ Wireless Communication Status

The status of wireless communication is indicated by the segments on the top of the integral indicator. Possible status are shown in Table 6.1.

Table 6.1 Wireless Communication Status List

Integral Indicator	Wireless Communication Status
No display	<ul style="list-style-type: none"> • RePause (Silence mode) • ReOperation (Published)
-	<ul style="list-style-type: none"> • Ready • Joining
- - - - -	<ul style="list-style-type: none"> • Confirm connecting status
- - - - -	<ul style="list-style-type: none"> • Startup • Alert

■ Process Value

The process value obtained from the sensor is displayed. For detail information about the display settings, refer to section 7 “Setting Parameters”.

When sensor data is more than five orders of magnitude, scroll automatically after 2 seconds.



F0608.ai

Figure 6.8 Example of Data Scrolling

When publish is not configured, following is displayed.

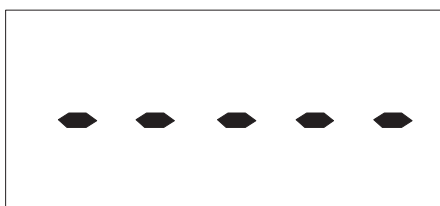

F0609.ai

Figure 6.9 Display when Publish is not Configured

■ Startup

When the FN510 powers on or recovers from the deep sleep mode, the following is displayed for 2 seconds.

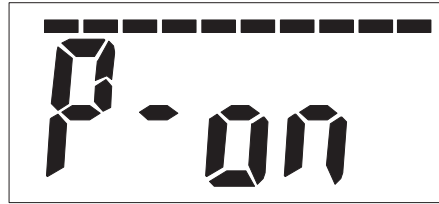

F0610.ai

Figure 6.10 Display after Power On

■ Setting the Find Device

When UAPMO.Find Device is set from FieldMate or PRM, following is displayed. The duration the display can be changed. For detail on how to display, refer to section 7 “Setting Parameters”.

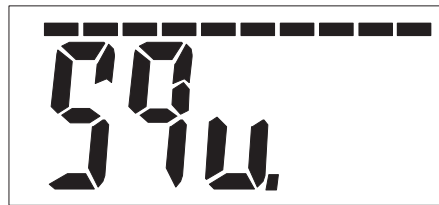

F0611.ai

Figure 6.11 Display when Find Device is set

6.5 Shutting Down

When shut down the FN510, remove the battery pack or set the FN510 to deep sleep mode by the device configuration tool or magnet switch.



NOTE

- Refer to subsection 8.3 “Replacing the Battery Pack” for the battery pack removing.
- When storing the FN510 with a battery pack inserted, it is recommended to put the FN510 into deep sleep mode to conserve battery power. For details on how to switch to deep sleep mode, refer to subsection 7.3.9 “Switching to the Deep Sleep Mode”.

7. Setting Parameters

FN510 can remotely handle sensor type changes, Tag No. setup, monitoring of self-diagnostic results, according to communication with the field wireless configuration tool or the device configuration tool.

7.1 Preparation for Parameter Setting

This product can be set parameters via infrared port or field wireless network.

When setting parameters via field wireless network, connect this product to the field wireless network.

For details on how to connect to the field wireless network, refer to subsection 6.3 “Connecting to the Field Wireless Network”.

When setting parameters via infrared port, use the infrared port on front of this product.

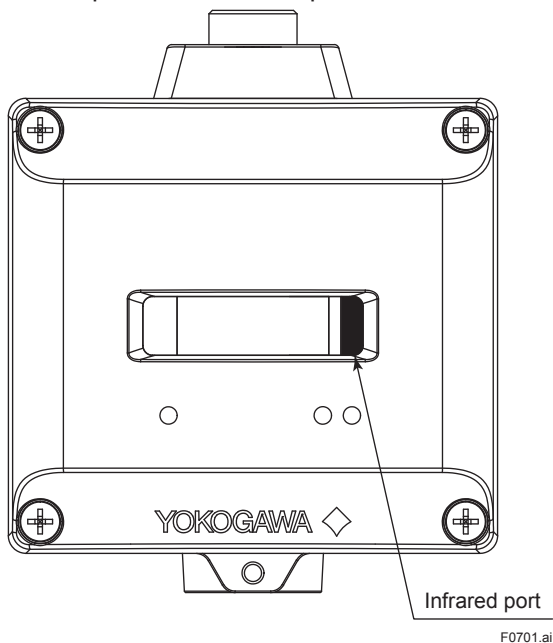

Figure 7.1 Connecting the Configuration Tool

7.2 Preparing Software

7.2.1 Softwares for the Field Wireless Configuration Tool and the Device Configuration Tool

Before using the device configuration tool, confirm that CF/DD and DeviceDTM for this product are installed in the device configuration tool.

Refer to the following website for the latest information on CF/DD and DeviceDTM.

<<http://www.field-wireless.com/>>

CF(Capabilities File)/DD(Device Description)

A CF file contains information, such as the vendor of the field device, its model and revision, available types of process data (flow rate, temperature, pressure, etc.), and number of data items. A DD file contains the information on parameters, such as data structures and attributes.

DeviceDTM

DeviceDTM, (Device Type Manager) is driver software for field devices provided based on the FDT (Field Device Tool) technology.

The field wireless configuration tool or the device configuration tool allows to read the device information.

Refer to subsection 8.2 “Recommended Products List” for the field wireless configuration tool or the device configuration tool of our recommendation.

Refer to the following website for the latest configuration tool and DeviceFile.

<<http://www.field-wireless.com/>>

7.2.2 Software Download

Software download function allows to update wireless field device software via ISA100.11a wireless communication. For details, refer to YFGW710 Field Wireless Integrated Gateway (IM 01W01F01-01EN) or YFGW410 Field Wireless Management Station (IM 01W02D01-01EN).

7.3 Setting Parameters

7.3.1 Parameter Usage and Selection

Before setting a parameter, please see the following table for a summary of how and when each parameter is used.



IMPORTANT

After setting and sending data with the field wireless configuration tool or the device configuration tool, wait 30 seconds before turning off the FN510. If it is turned off too soon, the setting will not be stored in the FN510.

Table 7.1 Parameter Usage and Selection

Item	Description
Tag No.	Sets the Tag No. for Device Tag (software tag). The Tag No. can be set sixteen characters (alphanumeric characters, including –).
Output mode	Allows outputting process value and self-diagnostic information via field wireless network. Either or all of sensor value (AI1 block: Process Value, BI1/BI2 block: Process Value Binary, BO1 block: Read Back Value Binary), and self-diagnostic information (UAPMO block: Diagnostic Status) can be set output data.
Input mode	Allows inputting process value via field wireless network. Sensor value (BO1:Output Value Binary) can be set as input data.
Integral indicator display setting	Sets the process value to display on the LCD.
Software write protect	Prohibit writing the setting data.
Memo field	Memo field available to write the check date, checker and others (as an adjustment information), or anything.
Operational mode	Set the operational mode of the sensor and integral indicator, etc.



NOTE

Some of the parameter setting are in the dialogue form called method, by following the on-line instructions you can configure the parameters easily.

7.3.2 Function Block and Menu Tree

(1) Function Block

The function of FN310 is shown below. Some functions may not be available depending on the device configuration tool used. When the device configuration tool of our recommendation is used, the software attached to the Field Wireless Integrated Gateway or Field Wireless Management Station is necessary for setting the dotted line part. Refer to subsection 8.2 "Recommended Products List" for the field wireless configuration tool of our recommendation.

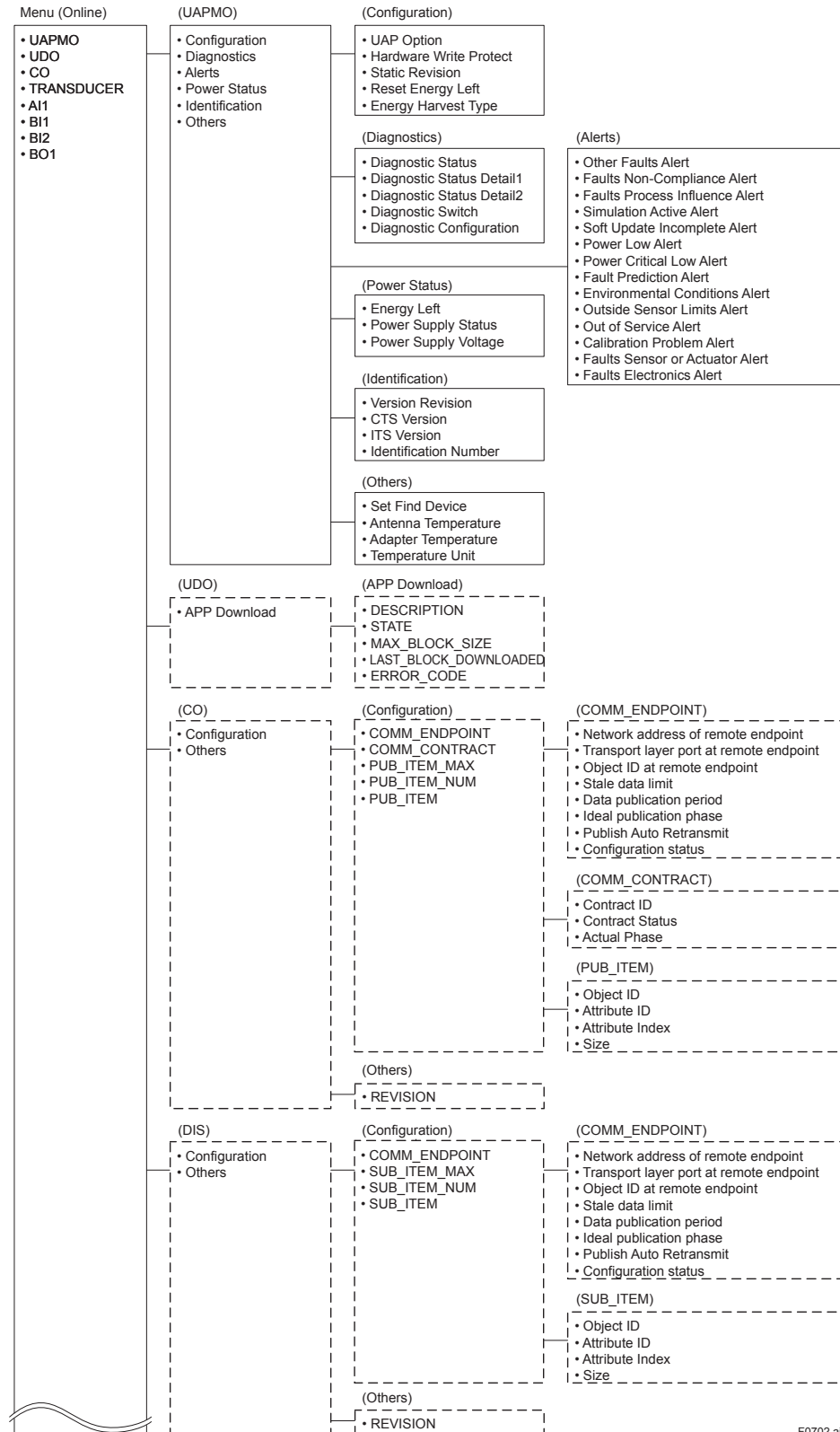

F0702.ai

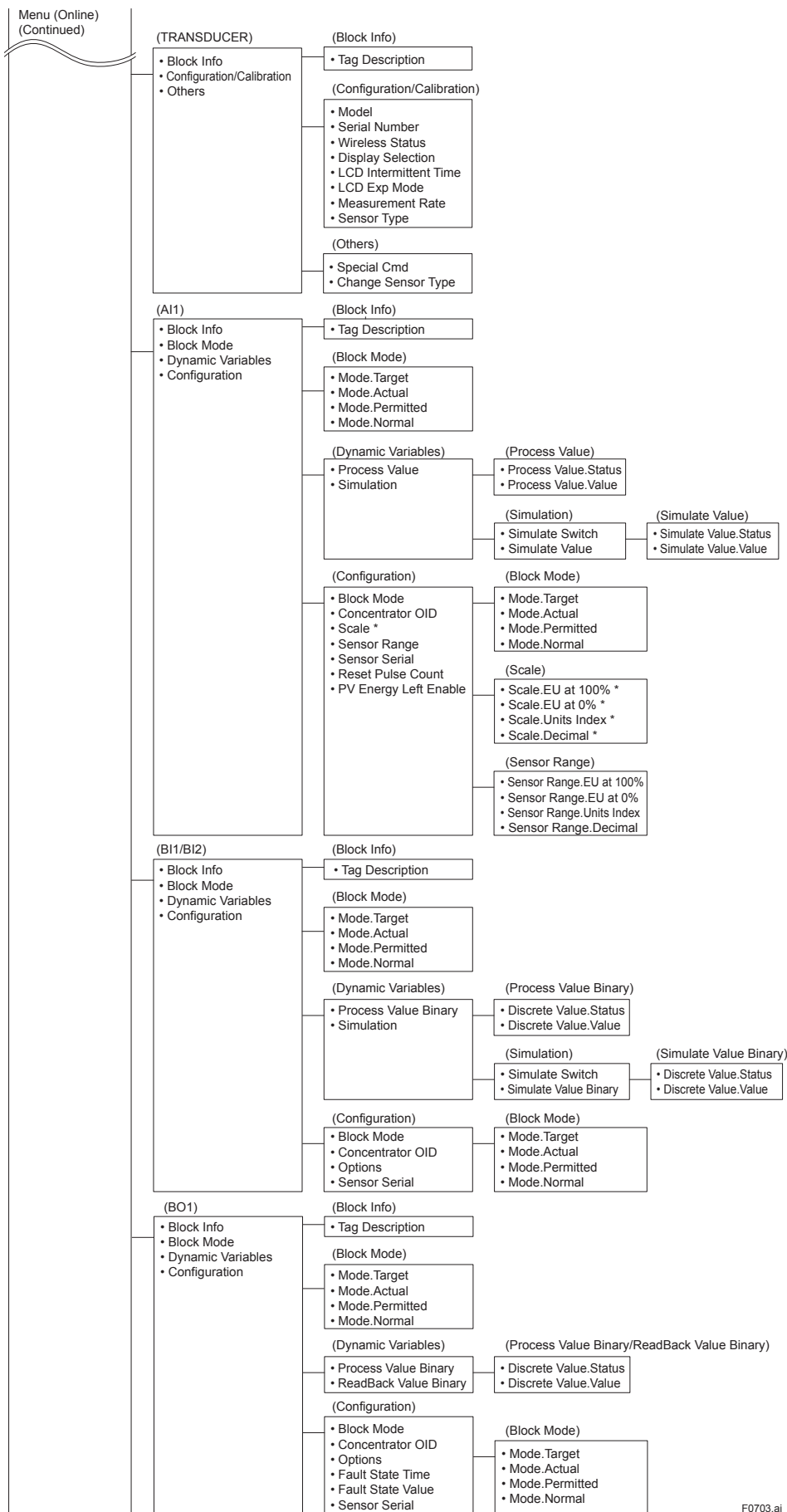

F0703.ai

* When the data of these parameters is rewritten, it is necessary to set the operational mode of the block to O/S (Out of Service).

(2) Menu Tree

The menu tree of our recommended device configuration tool is shown below. Refer to subsection 8.2 “Recommended products list” for the device configuration tool of our recommendation.

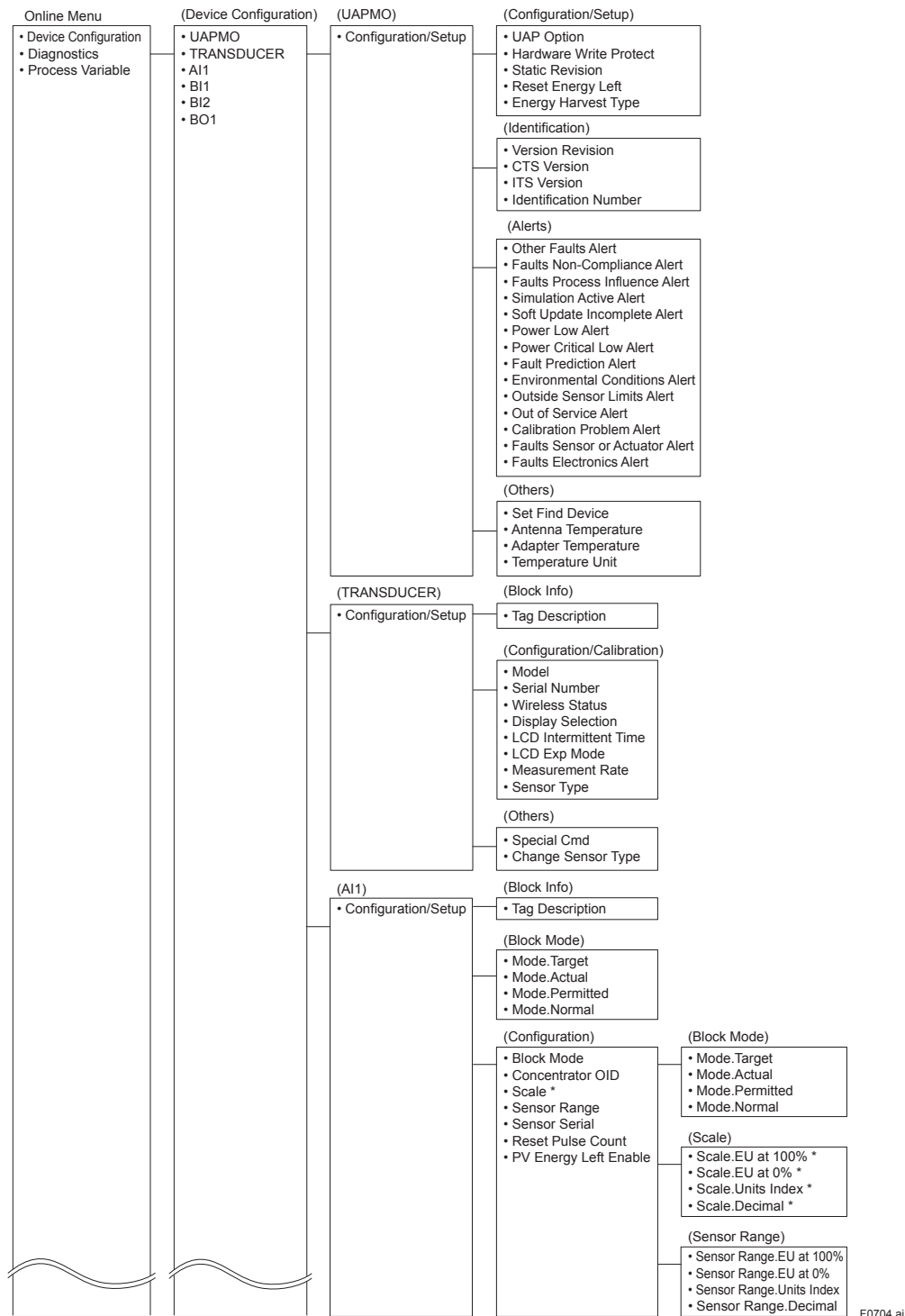

F0704.ai

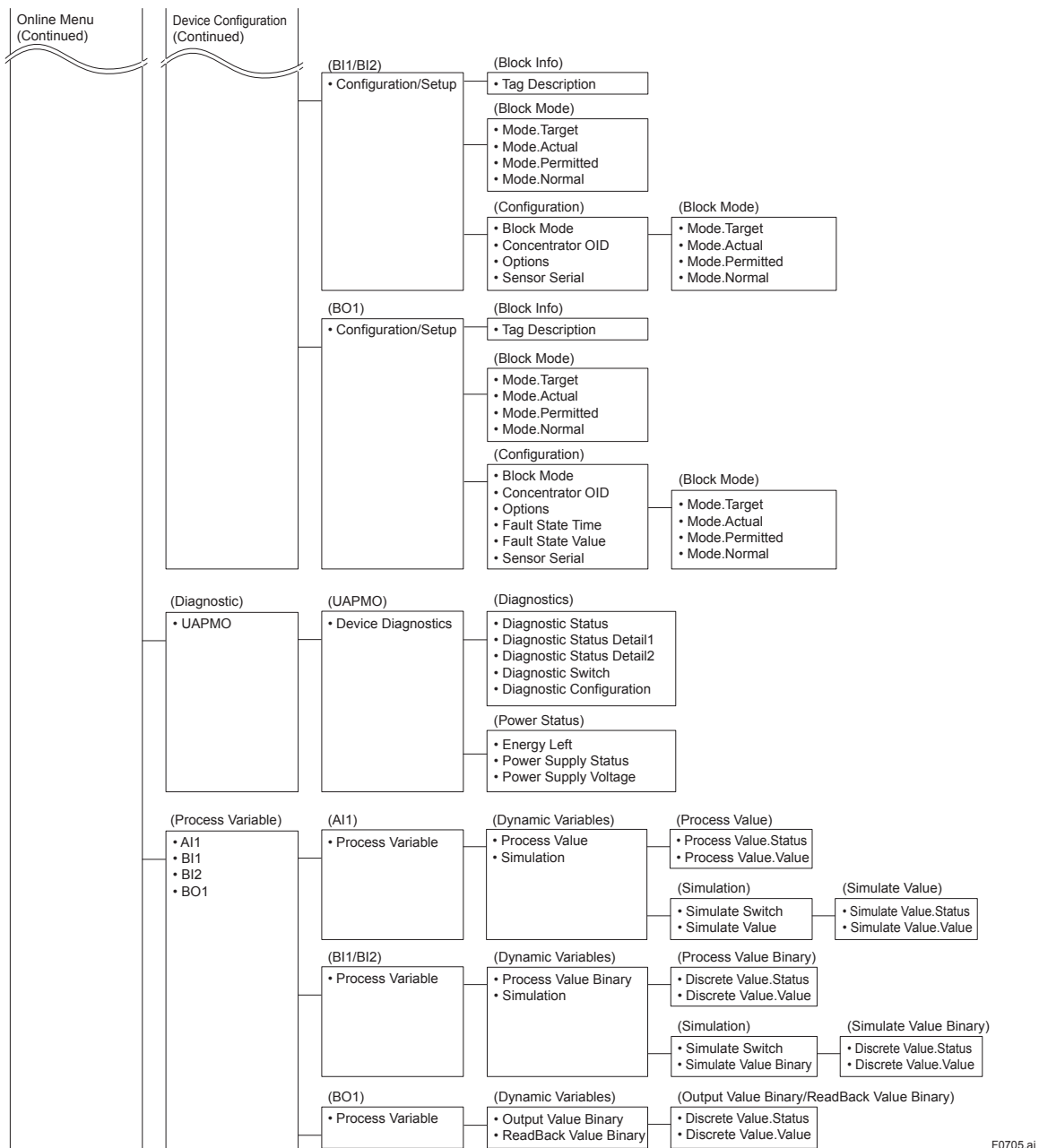

* When the data of these parameters is rewritten, it is necessary to set the operational mode of the block to O/S (Out of Service).

F0705.ai

7.3.3 Parameters for Wireless Communication

(1) Network Information

CO block: Configuration

The network-related information can be checked.

DIS block: Configuration

Information related to the communication handled by DO can be checked.

(2) Update Time

CO block: Data publication period

DIS block: Data publication period

For AI, DI Pulse Count, and DI, set the update time value to the data publication period in the CO block within the range of 1 to 3600 seconds. For DO, set the update time value to the data publication period in the DIS block within the range of 2 to 3600 seconds.



NOTE

If you want to use DI and DO together, the update time value of DI should be set to 2 seconds or more.

The setting affects the battery life.

When update time is set 0 second, FN510 stops updating process variables via the field wireless network. And it also stops the acquisition of process variables from the connected device.

(3) Remaining Battery Life

UAPMO block: Energy Left

The number of days of battery life remaining is indicated assuming ambient temperature condition as 23 °C. It takes several days for the value to be stabilized after the power on and initialization of the remaining battery life.

UAPMO block: Reset Energy Left

When changing batteries, the remaining battery life is initialized by Reset Energy Left parameter.

(4) LCD Display

TRANSDUCER block: LCD Intermittent Time

The integral indicator has three modes: Continuous, Intermittent, and Off. These modes are switched by LCD Intermittent Time parameter. The intermittent mode repeats on/off at defined seconds.

In any mode, current process value is displayed by magnet switch operation. After displaying current process value, returns to the configured mode. Refer to subsection 8.6 “Switching LCD Display” for details.



NOTE

When the FN510 detects AL.01, AL.02 and AL.03 error, the LCD display does not dim regardless of the status in LCD mode. See Table 8.4 for details.

7.3.4 Tag and Device Information

You can specify the Device Tag when ordering the corresponding FN110 Field Wireless Communication Module.

Device Tag and device information can be checked as follows.

■ Procedure to Read the Device Tag and Device Information

- Device Tag (Software Tag)
This is specified by writing characters (up to 16 characters) that differs from those specified in Tag No. to the module. For details how to confirm this, refer to subsection “Connecting to the Field Wireless Network”.
- Tag Description
This is a universal parameter to store the comment that describes the content of the tag located in the TRANSDUCER and AI1/BI1/BI2/BO1 blocks.

■ Limitation of Device Information

When changing the device information, input the information based on the following limitation on the number of characters.

- Message function (up to 32 characters)
TRANSDUCER block: Tag Description
AI1/BI1/BI2/BO1 block: Tag Description

7.3.5 Setup the Integral Indicator

TRANSDUCER block: LCD Exp Mode

Set the display method of the PV on the integral indicator. Index display or base display is selectable.

7.3.6 Sensor Type

Process values are assigned as shown in the table below depending on the Sensor Type.

Table 7.2 Block Assignment

Sensor Type	Assignment to Block
DIDO	BI1 block (IN1) BI2 block (IN2) BO1 block (OUT)
DI Pulse Count	AI1 block
4-20mA	AI1 block
Not Used	AI1 block (Energy Left *)

*: Valid if PV Energy Left Enable of AI1 block is set to Enable.

7.3.7 Parameters for Function

■ DI Pulse Count

AI1 block: Reset Pulse Count

When this parameter is set to Reset, DI Pulse Count value will be reset if the Sensor Type is set to DI Pulse Count. The count range is 0 to 999999.



NOTE

When restart FN510 by removing the battery pack, start counting from 0.

■ 4-20 mA

AI1 block: Scale

To change the scaling range, change the following parameters. Before changing these parameters, it is necessary to set the operational mode of AI1 block to O/S (Out of Service).

- Parameter for lower limit
AI1 block: Scale:EU at 0%
- Parameter for upper limit
AI1 block: Scale:EU at 100%

Specify the parameters for lower limit (EU at 0%) and upper limit (EU at 100%) in the unit set in the unit parameter (Units Index).

■ DI

BI1/BI2 block: Options

Output value will be inverted if Invert parameter is set.

■ DO

BO1 block: Output Value Binary

A value written via field wireless network will be stored.

BO1 block: Read Back Value Binary

The DO output value will be stored. This parameter can be specified as a parameter to be published to the field wireless network.

BO1 block: Options, Fault State Time, Fault State Value

Inverts the DO output, sets the DO output value at failure or startup and sets the time until that value will be valid.

DIS block: Stale data limit

Writing to BO1 block via field wireless network is not performed within the time multiplied by the Stale data limit in the Data publication period, FN510 sends alert.



IMPORTANT

- When restart FN510 by removing the battery pack, output value follows the specified Options parameter in the BO1 block.
- When switching to the deep sleep mode or silence mode, FN510 holds the output value set from field wireless gateway just before or specified Options parameter in the BO1 block.
- To minimize the consumption of the battery, set the output value of BO1 block Off (Open), and then switch to the deep sleep mode.
- When stopping the use of BO1 block, delete the settings related to BO1 block from field wireless gateway, and then restart the FN510 by removing the battery pack.

■ Routing Device

AI block: PV Energy Left Enable

FN510 can be used as a routing device if Sensor Type is set to Not Used. In this setting, Energy Left can be stored in AI1.PV.Value, and then published to the field wireless network.

7.3.8 Write Protect

Hardware write protection and software write protection functions are available for FN510.

■ Hardware Write Protection

Hardware Write Protection is set by slide switch on the front panel back.

■ Software Write Protection

Software Write Protection is set by the parameter of software write protect of UAP Option in UAPMO block.

For the relationship between hardware write protection and software write protection, refer to section 9 "Parameter Summary".

7.3.9 Switching to the Deep Sleep Mode

When the FN510 will not be used for a long time, switch the FN510 to the deep sleep mode to conserve battery power. There are two methods of switching to the deep sleep mode. To switch to deep sleep mode, follow the procedure below.

■ **Magnet Switch Operation**

Procedures for switching to the deep sleep mode using a magnet switch are as follows.

1. Touch the magnet switch 1 for 5 seconds by a magnet (LCD displays "SLEEP" flashing).
2. Touch the magnet switch 1 for an additional 5 seconds by a magnet (LCD displays "SLEEP").
3. Touch the magnet switch 2 within next 5 seconds by a magnet.

■ **Write Parameter**

TRANSDUCER block: Special Cmd
Set deep sleep mode to Special Cmd parameter.

There are three methods to start from the deep sleep mode.

■ **Restart**

Restart by re-connection of the battery pack.

■ **Infrared Communication**

Start by receiving infrared communication. Use the wireless field device configuration tool (for infrared) or device provisioning tool.

■ **Magnet Switch Operation**

Start by touching a magnet to magnet switch 1 for 10 seconds.



CAUTION

After setting the deep sleep mode by infrared device configuration tool, keep the infrared port of device away from any other infrared signals.



NOTE

- After switching to deep sleep mode, the FN510 stops any field wireless communication. For this reason, there is the case that an error is displayed on field wireless configuration tool.
 - To wake up from deep sleep mode by reconnection of battery pack, please pull battery pack and wait more than 30 seconds before attaching battery pack.
-

7.3.10 Switching to the Silence Mode

This is a function to pause the FN510 when it cannot join the field wireless network after a specified time has elapsed. This function is effective in conserving battery power when, for example, the installation of the Field Wireless Integrated Gateway is delayed compared to that of field wireless devices. When the FN510 fails to search the network for about 120 minutes, it switches to silence mode automatically. Thereafter, a cycle of 18 minutes pause and 36 seconds search is repeated until the FN510 can join the field wireless network. To minimize the consumption of the battery, the FN510 turns off the integral indicator and stops the measurement.

To start from the silence mode, either removes and inserts the battery pack, or receiving infrared communication. Use the device configuration tool (for infrared) or device provisioning tool.

7.4 Self-Diagnostics

7.4.1 Identify Problems by Using the Device Configuration Tool

The device configuration tool allows checking the self-diagnostic results and settings of the FN510. First, check Diagnostic Status of the self-diagnostic results.

■ Procedure to Call Up the Self-Diagnostic Parameter

UAPMO block: Diagnostic Status

Any of the four categories (Function check, Maintenance required, Failure, and Out of specification) according to NAMUR NE107 is supplied to Diagnostic Status of each diagnostic result.

Checking the Diagnostic Status category allows taking the proper action. The Diagnostic Status contents are common for all ISA devices, and the setting for the Diagnostic Status category can be changed. For further details, refer to Diagnostic Status Detail.

In Diagnostic Status Contents that can be diagnosed by the FN510, the alert category set in Out of Service can be changed to Function check. To do so, follow the procedures below.

1. UAPMO block: UAP Option Enable diagnostic status configuration select “enable”.
2. UAPMO block: Diagnostic Configuration change Out of Service from “Failure” to “Function check”.
3. UAPMO block: UAP Option Enable diagnostic status configuration select “disable”.

In Diagnostic Configuration setting, select one from the followings;

- F: Failure Status
- C: Function check status
- O: Out of specification status
- M: Maintenance required status

The contents of Diagnostic Status are defined either valid or invalid at Diagnostic Switch parameter.

Follow the example below to change “Out of Service” to invalid.

1. UAPMO block: UAP Option Enable diagnostic status configuration select “enable”.
2. UAPMO block: Diagnostic Switch turn “Off” for Out of Service.
3. UAPMO block: UAP Option Enable diagnostic status configuration select “disable”.



NOTE

Be careful when changing the alert category and turning detection on and off as described above. Be sure to set UAP Option Enable diagnostic status configuration to disable again to prevent setting errors.

7.4.2 Alert Report

FN510 generates alert information related to Diagnostic Status and automatically sends to a field wireless gateway. To use this function, the following alert setting is necessary. When “Out of Service” for Diagnostic Status alert is required, choose “FALSE” for [Out of Service. Alert Disable] in the UAPMO block. Refer to the field wireless gateway User’s Manual for the setting procedure to obtain the alert information from the gateway.

The alert report consists of the list of parameter name as shown Table 7.3.

Table 7.3 Contents of Alert Report

Parameter name	Description
DetectObjectTLPort	Alert detection port UAP (0xF0B2) fixed
DetectObject	Alert detection block UAPMO (1) fixed
DetectTime	Time stamp
AlertDirection	1: generated, 0: clear
AlertPriority	Alert priorities set by users
AlertType	Alert types, see Alert Type in Table 7.5
AlertValue	NAMUR107 category 0: Failure 1: Function Check 2: Out Of Specification 3: Maintenance Required



CAUTION

For a wireless gateway which does not support the alert report function, the alert setting in UAPMO block for this product must be set to “Disable”. Note that YFGW710 Field Wireless Integrated Gateway does not have the alert report function.

7.4.3 Checking with Integral Indicator



NOTE

If an error is detected by running self-diagnostics, an error number is displayed on the integral indicator. If there is more than one error, the error number changes at 2 seconds interval. See table 8.4 regarding the alarm codes.



Figure 7.2 Error Check with Integral Indicator

Table 7.4 Diagnostic Status

Bits	Contents	NAMUR NE107 Categorization*
Bit31(MSB)	F:Failure status	---
Bit30	C:Function check status	---
Bit29	O:Out of specification status	---
Bit28	M:Maintenance required status	---
Bit27	Faults in electronics	F
Bit26	Faults in sensor or actuator element	F
Bit25	Installation, calibration problem	C
Bit24	Out of service	C
Bit23	Outside sensor limits	O
Bit22	Environmental conditions out of device specification	O
Bit21	Fault prediction: Maintenance required	M
Bit20	Power is critical low: maintenance need short-term	M
Bit19	Power is low: maintenance need mid-term	M
Bit18	Software update incomplete	C
Bit17	Simulation is active	C
Bit16	Faults due to process influence	F
Bit15	Faults due to non-compliance with specified operating conditions	F
Bit14	Other faults	F
Bit13-Bit09	reserved by WCI	---
Bit08-Bit01	vendor specific area	---
Bit00	Detail information available	---
	1: available	
	0: no available	

* NAMUR NE107 "Self-Monitoring and Diagnosis of Field Devices"

Table 7.5 Diagnostic Results Summary

Diagnostic Status Contents	Alert Type	NAMUR NE107 Category*	Diagnostic Status Detail	Description
Faults in electronics	78	F	ADAPTER FAIL	FN510 failure
			ANTENNA FAIL	FN110 failure
			INTERNAL BUS FAIL	Communication failure between FN110 and FN510
Faults in sensor or actuator element	77	F	SENSOR FAIL	Communication failure between FN510 and connected devices
			mA_FAIL	mA value is in the following range, which is not within the specification. 1.0 ≤ mA < 3.6, 21 < mA
Out of service	75	C	AI1 OUT OF SERVICE	AI1 O/S Mode
			BI1 OUT OF SERVICE	BI1 O/S Mode
			BI2 OUT OF SERVICE	BI2 O/S Mode
			BO1 OUT OF SERVICE	BO1 O/S Mode
Process Value out of limits	74	O	mA_OUTSIDE_LIMIT	mA value is in the following range, which is not within the specification. 3.6 ≤ mA < 4.0, 20 < mA ≤ 21
Environmental conditions out of device specification	73	O	ADAPTER TEMP HI	FN510 temperature is above +85°C
			ADAPTER TEMP LO	FN510 temperature is below -40°C
			ANTENNA TEMP HI	FN110 temperature is above +85°C
			ANTENNA TEMP LO	FN110 temperature is below -40°C
Power is critical low: maintenance need short-term	71	M	CRITICAL LOWBAT	Low battery alert
Power is low: maintenance need mid-term	70	M	LOWBAT_ALM	Low battery
Simulation is active	68	C	AI1 SIMULATION ACTIVE	AI1 Simulation Mode
			BI1 SIMULATION ACTIVE	BI1 Simulation Mode
			BI2 SIMULATION ACTIVE	BI2 Simulation Mode
Faults due to process influence	67	F	BO_STALE_LIMIT_FAIL	Detect Stale Limit

* NAMUR NE107 "Self-Monitoring and Diagnosis of Field Devices"

8. Maintenance

8.1 General

This chapter describes the procedures of replacing batteries and the status check method required for maintenance of FN510.

Please carefully and thoroughly read the following sections for information on how to properly handle this product while performing maintenance.

8.2 Recommended Products List

Table 8.1 lists the recommended products of our equipment needed to set up and use the FN510.

Table 8.1 Recommended Products List

Yokogawa-recommended Instrument
Provisioning Device Tool <ul style="list-style-type: none"> FieldMate (R2.03 or later) Provisioning Device Tool Infrared Adapter certified by Yokogawa Supplier: ACTISYS Product name: IrDA InfraRed USB Adaptor Product number: IR224UN-LN96 (9600bps)
Field Wireless Configuration Tool <ul style="list-style-type: none"> Field Wireless Integrated Gateway attached Software Field Wireless Configurator Field Wireless Management Tool Field Wireless Management Station attached Software Field Wireless Management Console
Device Configuration Tool <ul style="list-style-type: none"> FieldMate (R3.01.11 or later) DeviceFile (R3.06.01 or later)
Field Wireless System related Product <ul style="list-style-type: none"> Plant Resource Manager (PRM) (R3.20 or later) DeviceFile (R3.06.10 or later)

8.3 Replacing the Battery Pack



WARNING

- To ensure the installation minimizes the risk from electrostatic discharge. To prevent electrostatic discharge caused by static charge built up on the operator, ground the operator through conductive shoes and floors and by wearing anti-static work clothes to prevent charge build-up. Avoid any actions that cause the generation of electrostatic charge, such as rubbing surface of Battery Pack and product with a dry cloth. If static electricity cannot be suppressed, check that the surrounding atmosphere does not contain explosive gas or steam before replacing the Battery Pack.
- Be sure to use a battery pack that is indicated as “Rev.1” for explosion protected instruments.

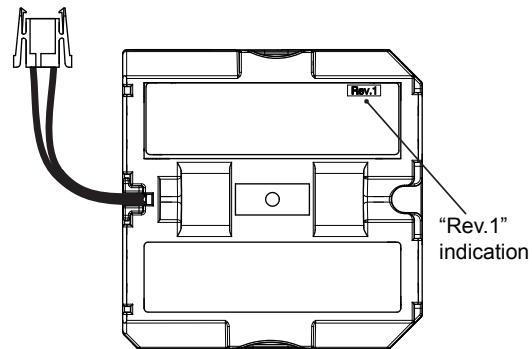

F0801.ai

The battery pack in an intrinsically safe explosion protected product can be replaced in the installed condition in a hazardous area.

■ Preparation

Initialize the value of remaining battery life. To initialize the battery life, set the Reset Energy Left parameter in UAPMO block. When the FN510 stop working because of low battery, initialize the remaining battery life immediately after replacing the battery pack. In the case of initialize the remaining battery life after replacing the battery pack, perform warm restart after initializing. For details on how to warm restart, refer to field wireless gateway User’s Manual (IM 01W02D01-01EN for YFGW410, IM 01W01F01-01EN for YFGW710).

■ Removing

1. Loosen the four screws on the front panel.
2. Pull the lever in the direction of the arrow in Figure 8.1.
3. Pull out the battery connector from the front panel back.
4. Pull the battery pack.

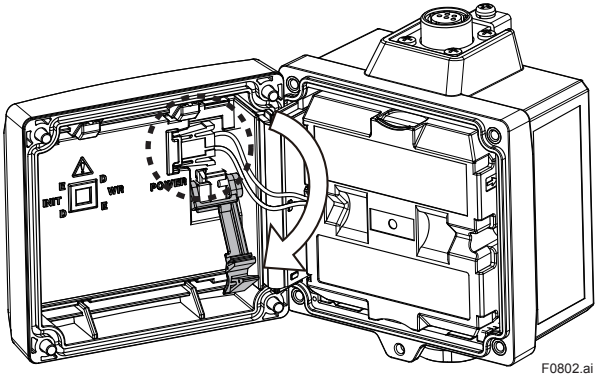

Figure 8.1 Removing the Battery Pack



After pulling out the battery connector, remove the battery pack.

■ Remounting

1. Insert the new battery pack. The orientation of the battery pack, "PART NO." display is the front and connector cable is left side.
2. Plug the battery connector into the terminal on the front panel back. Connect facing down the white surface of the connector. Push the connector until it touches the back of the front panel then slide it to the left.
3. Push the lever in the direction of the arrow in Figure 8.2.
4. Close the front panel and tighten the four screws to a torque of 0.7 N • m.

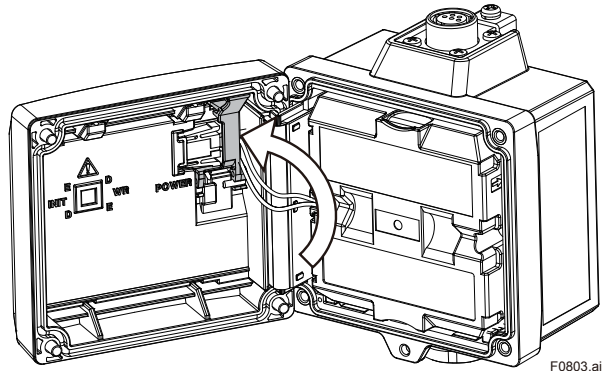

Figure 8.2 Remounting the Battery Pack

8.4 Replacing the Batteries

The batteries in the battery pack can be replaced. Batteries are not installed when shipped from the factory. Assemble the battery pack as follows.

WARNING

Be sure to replace the batteries or open and close the battery pack in a non-hazardous area. Doing so in a hazardous area could cause an explosion.

CAUTION

When replacing the batteries, be sure to replace the two batteries at the same time and do not use an old and a new battery together.

■ Disassembling

1. Loosen a battery case fixing screw.
2. Remove old batteries. Remove the battery by pushing up the negative side of the battery as shown in Figure 8.3.

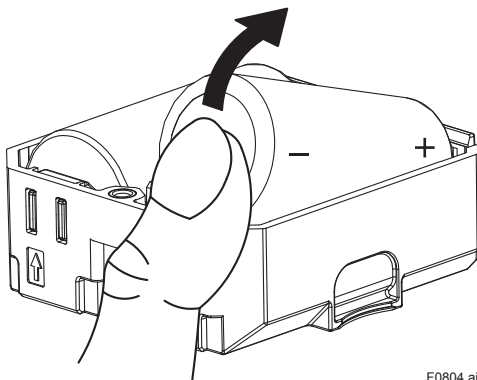

F0804.ai

Figure 8.3 Remove Batteries

■ Assembling

1. Insert new batteries into the battery case. Check the orientation of the battery and push straight.
2. As shown in Figure 8.4, engage the hooks on the opposite side of the screw.
3. Tighten the screw to a torque of 0.7 N • m.

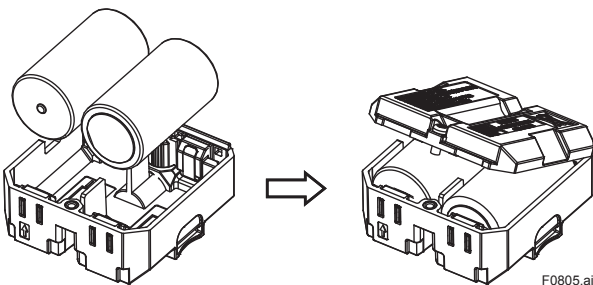

F0805.ai

Figure 8.4 Assembling the Battery Pack

8.5 Handling Batteries

This battery pack uses two primary lithium-thionyl chloride batteries. Each battery contains approximately 5 grams of lithium, for a total of 10 grams in each pack. Under normal conditions, the battery materials are self-contained and are not reactive as long as the batteries and the pack integrity are maintained. Care should be taken to prevent thermal, electrical or mechanical damage. Protect the electrode of the battery pack to avoid rapid electrical discharge. Discharged a battery may lead to fluid leakage and excessive heat. Batteries should be stored in a clean and dry area. For maximum battery life, storage temperature should not exceed 30°C.

WARNING

Handling the battery pack

The following precautions must be observed in order to safely and effectively use a battery pack. Improper use may lead to fluid leakage, excessive heat, ignition, or explosion.

- Never charge it.
- Do not short-circuit it.
- Do not disassemble, transform, or modify it.
- Do not heat it or throw it into a fire.
- Do not soak it in fresh water or seawater.

CAUTION

Observe the following precautions for the safe disposal of batteries.

- Do not incinerate the battery, and do not expose it to a high temperature of 100°C or more. This may lead to fluid leakage or explosion.
- Dispose of the battery according to laws and regulations.

Use the following dedicated parts for the battery pack and batteries.

■ Battery Pack

Part number: F9090FD^{*1} (with batteries)

Part number: F9090GD^{*2} (without batteries)

*1: If you need F9090FC, please purchase F9090FD. F9090FD is a set of F9090FC and instruction manual.

*2: If you need F9090GC, please purchase F9090GD. F9090GD is a set of F9090GC and instruction manual.

■ Batteries

Part number: F9915NR

Alternatively, following batteries may be purchased and used.

- Tadiran TL-5930/S or SL-2780/S
- VITZROCELL SB-D02

Transportation of products containing lithium batteries

Batteries used for this product contain lithium. Primary lithium batteries are regulated in transportation by the U.S. Department of Transportation, and are also covered by the International Air Transport Association (IATA), the International Civil Aviation Organization (ICAO), and the European Ground Transportation of Dangerous Goods (ARD). It is the responsibility of the shipper to ensure compliance with these or any other local requirements. Consult current regulations and requirements before shipping. When transporting this product with the battery pack inserted, keep it in deep sleep mode in order to conserve battery power. For details on how to switch to deep sleep mode, refer to subsection 7.3.9 “Switching to the Deep Sleep Mode”.

Procedure to replace and dispose of the batteries of the product

Below an explanation about the new EU Battery Directive (DIRECTIVE 2006/66/EC). This directive is only valid in the EU.

Batteries are used for this product. When you remove batteries from this product and dispose them, discard them in accordance with domestic law concerning disposal.

Take a right action on waste batteries, because the collection systems in the EU on waste batteries are regulated.

Battery type: Primary lithium-thionyl chloride battery
Crossed-out dustbin symbol



NOTE

The symbol (see above), which is marked on the batteries, means they shall be sorted out and collected as ordained in ANNEXII in DIRECTIVE 2006/66/EC

Procedure to remove the batteries safely

Refer to subsection 8.3 “Replacing the Battery Pack” and subsection 8.4 “Replacing the Batteries”.

8.6 Switching LCD Display

The process value and the wireless communication status are displayed on the LCD by touching a magnet to the magnet switch1. The contents of the display changes as follows every two seconds. If the Sensor Type in TRANSDUCER block is set to DIDO;

1. Wireless Communication Status. See Table 8.2.
2. Object Name (B1)
3. Process Value Binary of B1 block
4. Object Name (B2)
5. Process Value Binary of B2 block
6. Object Name (BO1)
7. Read Back Value Binary of BO1 block
8. Tag No. (If specified when ordering)

After display, return to normal display contents.

If the Sensor Type in TRANSDUCER block is set to other than DIDO;

1. Wireless Communication Status. See Table 8.2.
2. Object Name (A1)
3. Process Value of A1 block
4. Tag No. (If specified when ordering)

After display, return to normal display contents.

Table 8.2 Wireless Status

Integral Indicator	Description
<p style="text-align: right; font-size: small;">F0806.ai</p>	Searching for Backbone Router or Router to connect. It is not connected to the field wireless network.
<p style="text-align: right; font-size: small;">F0807.ai</p>	Discovering the connection destination, and is doing the Join process. It is not connected to the field wireless network.
<p style="text-align: right; font-size: small;">F0808.ai</p>	Complete the Join process and is doing the Publish settings.
<p style="text-align: right; font-size: small;">F0809.ai</p>	The publish setting is complete and has been sent the PV value to the field wireless network.
<p style="text-align: right; font-size: small;">F0810.ai</p>	Silence Mode. For more information about silence mode, refer to subsection 7.3.10 “Switching to the Silence Mode”.

8.7 Replacing the FN110

This subsection describes the procedure for replacing the FN110. Replace the FN110 as follows.

1. Back up the configuration of the FN510.
2. Remove the battery pack.
3. Remove the FN110, and install a new FN110.
4. Remounting the battery pack.
5. Restore the backed up configuration of the FN510.
6. Performing provisioning work.
7. Update the configuration of field wireless gateway.

To back up the configuration, use the device configuration tool, such as FieldMate. Performing provisioning work is necessary when replacing the FN110. Update the configuration information of the target device by using field wireless configuration tool. For details of provisioning, refer to subsection 6.3 "Connecting to the Field Wireless Network".

8.8 Replacing the FN510

This subsection describes the procedure for replacing the FN510. Replace the FN510 as follows.

1. Back up the configuration of the FN510.
2. Remove the battery pack.
3. Remove the FN110 and the connected device, and install them to the new FN510.
4. Remounting the battery pack.
5. Restore the backed up configuration of the FN510.

8.9 Replacing the Connected Device

This subsection describes the procedure for replacing the connected device.

- Replace the connected device as follows.
1. Remove the battery pack.
 2. Remove the connected device from the FN510
 3. Install a new one.
 4. Remounting the battery pack.

8.10 Troubleshooting

If any abnormality appears in the measured values, use the troubleshooting flow chart below to isolate and resolve the problem. Since some problems have complex causes, these flow charts may not identify all. If you have difficulty isolating or correcting a problem, contact Yokogawa service personnel.

8.10.1 Basic Troubleshooting Flow

First determine whether the process variable is actually abnormal or a problem exists in the measurement system. If the problem is in the measurement system, isolate the problem and decide what corrective action to take. FN510 is equipped with a self-diagnostic function which will be useful in troubleshooting, and this product is equipped with an integral indicator and it will show an alarm code as a result of self-diagnosis.

See subsection 8.10.3 "Errors and Countermeasures" for the list of alarms.

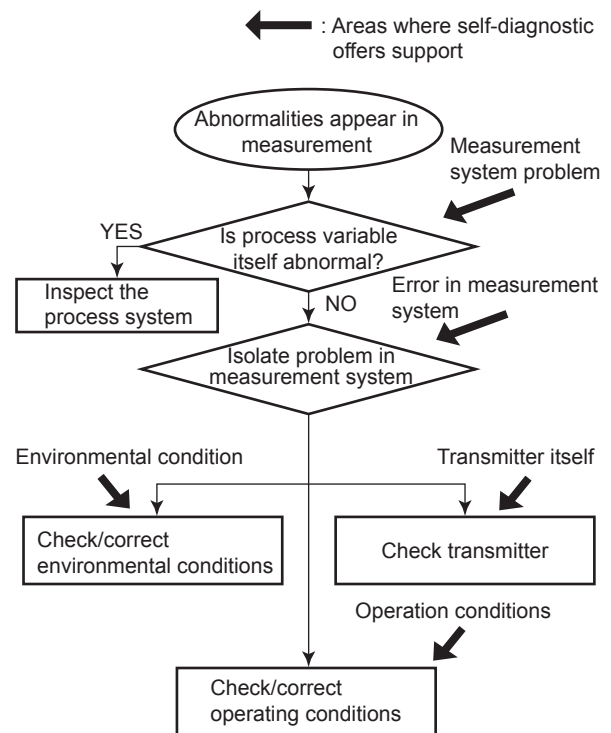

Figure 8.5 Basic Troubleshooting Flow

F0811.ai

8.10.2 Example of Troubleshooting Flow

The following shows an example of the flow for troubleshooting.

Refer to this example and Table 8.3. Locate the problem and take the corresponding countermeasure.

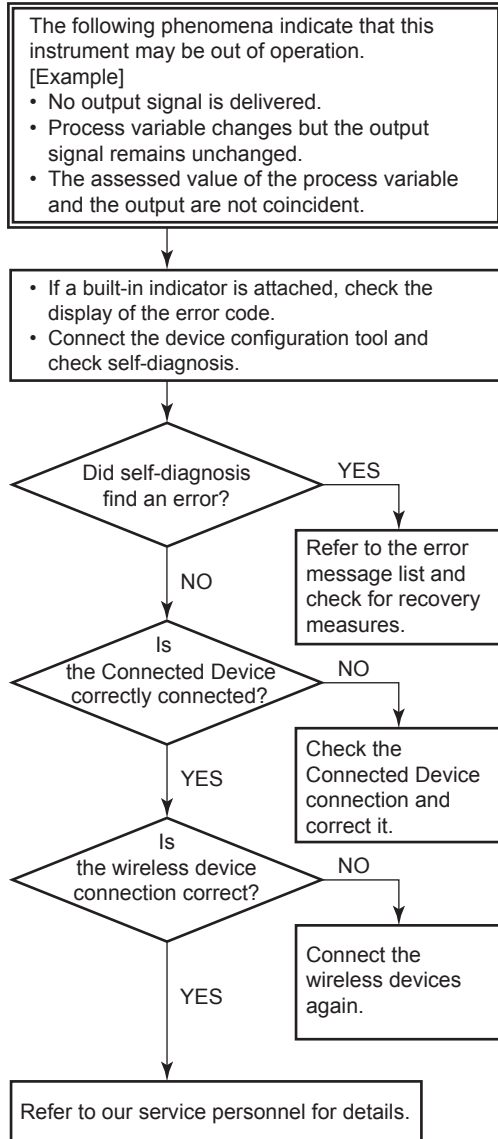

F0812.ai

Figure 8.6 Example of Troubleshooting Flow

Table 8.3 Cause and Countermeasure

Observed Problems	Possible Cause	Countermeasure	Related Parameter
Outputs fixed current.	The simulation function is set to ON.	Set the simulation function to OFF.	• Simulate Switch
Parameters cannot be changed.	This product is in write protect status.	Release write protect.	• UAP Option • Hardware Write Protect
The status of the output is Out of Service even if the Modo.Target is set to Auto.	Sensor Type is not properly set.	Set the Sensor Type properly.	• Sensor Type
Energy Left value does not increase after replacing the battery pack.	Reset Energy Left function has not been executed.	Execute the Reset Energy Left function.	• Reset Energy Left

8.10.3 Errors and Countermeasures

Table 8.4 Error Message Summary

Integral indicator	NAMUR NE107 category *1	Bit	Diagnostic Status	Diagnostic Status Detail	Cause	Release/recovery conditions (except restart) *2	Output Operation	Action
AL.01 *3	F	27	Faults in electronics	ADAPTER FAIL	FN510 failure	None	Output value: Hold previous value Output status: BAD Device Failure	Contact Yokogawa service personnel.
AL.02 *3				ANTENNA FAIL	FN110failure			
AL.03 *3				INTERNAL BUS FAIL	Communication failure between FN110 and FN510	Recovers communication between FN110 and FN510		
AL.10	F	26	Faults in sensor or actuator element	SENSOR FAIL	Disconnection or communication error, between the connected device and FN510	None	Output value: Hold previous value Output status: BAD Sensor Failure	Check if the connected device is properly connected to FN510. Replace the device if it is properly connected.
AL.11	F	16	Faults due to process influence	BO_STALE_LIMIT_FAIL	Detects Stale Limit in the communication to the BO1 block.	Recovers when write to BO1 block is successful	Normal action	Check writing to BO1 block via field wireless network has been successful.
AL.12	F	26	Faults in sensor or actuator element	mA_FAIL	mA value is in the following range, which is not within the specification $1.0 \leq \text{mA} < 3.6, .$ $21 < \text{mA}$	Recovers when the mA value returns within the specification	Output value: Normal Output status: BAD Sensor Failure	Check the input current
AL.20	M	20	Power is critical low: maintenance need short-term	CRITICAL LOWBAT	Low remaining battery voltage	None	Normal action	Replace the batteries.
		19	Power is low: maintenance need mid-term	LOWBAT ALM	Low remaining battery voltage			
AL.41	O	23	Process Value out of limits	mA_OUTSIDE_LIMIT	mA value is in the following range, which is not within the specification. $3.6 \leq \text{mA} < 4.0, 20 < \text{mA} \leq 21$	Recovers when the mA value returns within the specification	Output value: Normal Output status: Uncertain: Range Limits Exceeded	Check the input current

Integral indicator	NAMUR NE107 category *1	Bit	Diagnostic Status	Diagnostic Status Detail	Cause	Release/recovery conditions (except restart) *2	Output Operation	Action	
AL.45	O	22	Environmental conditions out of device specification	ADAPTER TEMP HI	FN510 temperature is above +85°C	Recovers when the temperature returns to +85°C below	Normal action	Check the ambient temperature of the FN510	
				ADAPTER TEMP LO	FN510 temperature is below -40°C	Recovers when the temperature returns to -40°C or more			
				ANTENNA TEMP HI	FN110 temperature is above +85°C	Recovers when the temperature returns to +85°C below		Check the ambient temperature of the FN110	
				ANTENNA TEMP LO	FN110 temperature is below -40°C	Recovers when the temperature returns to -40°C or more			
AL.60	C	24	Out of service	AI1 OUT OF SERVICE	AI1 block is O/S mode	Recover when the mode target of alert block is other than O/S	Output value: Hold previous value Output status: BAD Configuration Err	Check the AI1 block setting	
				BI1 OUT OF SERVICE	BI1 block is O/S mode			A Check the BI1 block setting	
				BI2 OUT OF SERVICE	BI2 block is O/S mode			Check the BI2 block setting	
				BO1 OUT OF SERVICE	BO1 block is O/S mode			Check the BO1 block setting	
AL.61	C	17	Simulation is active	AI1 SIMULATION ACTIVE	Simulate Switch of AI1 block is enabled	Recover when the Simulate Switch of target block is set to disable	Output Simulate Value of AI1 block	Check the AI1 block setting	
				BI1 SIMULATION ACTIVE	Simulate Switch of BI1 block is enabled			Output Simulate Value of BI1 block	Check the BI1 block setting
				BI2 SIMULATION ACTIVE	Simulate Switch of BI2 block is enabled			Output Simulate Value of BI2 block	Check the BI2 block setting

*1: "NAMUR NE107 category" refers to the four categories (C: Function check, M: Maintenance required, F: Failure, and O: Out of specification) according to NAMUR NE107 "Self-Monitoring and Diagnosis of Field Devices".

*2: Except for the restart

*3: When the device detects "AL.01", "AL.02", and "AL.03", integral indicator displays regardless of the LCD Mode.

9. Parameter Summary

Table 9.1 Parameter Summary

Object ID	Attribute ID	Label	Description	Default value	Handling *1																					
1. UAPMO block	1	Version Revision	Indicates the application revision of FN510. This revision changes when the application software is downloaded.	---	R																					
	10	Static Revision	Indicates the revision level of the fixed parameters of UAP. Used, for example, to check whether parameters have been changed.	---	R																					
	64	Identification Number	Indicates the vendor ID, model ID, and revision of the device.	---	R																					
	65	CTS Version	Indicates the version of the communication stack test system (CTS).	0	R																					
	66	ITS Version	Indicates the version of the interoperability test system (ITS).	0	R																					
	67	Diagnostic Status	Indicates the diagnostic results of the device based on the NAMUR NE107 *2 model. Setting Enable diagnostic status configuration in UAP Option to Enable allows turning OFF and ON the display of the diagnostic results for each summary, and changing Categorize.	---	R																					
	68	UAP Option	Allows setting the Diagnostic Status and write protection of UAP. 1. Software write protect 1: On, 0: Off (default) 2. Enable hardware write protect 1: Enable, 0: Disable (default) 3. Enable diagnostic status configuration 1: Enable, 0: Disable (default) The following table shows the relationship between the hardware write protection and software write protection.	1. Off 2. Disable 3. Disable	W(P)																					
				<table border="1"> <thead> <tr> <th>Enable hardware write protect</th> <th>Hardware write protect</th> <th>Software Write protect</th> <th>write protect</th> </tr> </thead> <tbody> <tr> <td>Disable</td> <td>Off or On</td> <td>Off</td> <td>No</td> </tr> <tr> <td>Disable</td> <td>Off or On</td> <td>On</td> <td>Protected</td> </tr> <tr> <td>Enable</td> <td>Off</td> <td>Off or On</td> <td>No</td> </tr> <tr> <td>Enable</td> <td>On</td> <td>Off or On</td> <td>Protected</td> </tr> </tbody> </table>	Enable hardware write protect	Hardware write protect	Software Write protect	write protect	Disable	Off or On	Off	No	Disable	Off or On	On	Protected	Enable	Off	Off or On	No	Enable	On	Off or On	Protected		
	Enable hardware write protect	Hardware write protect	Software Write protect	write protect																						
	Disable	Off or On	Off	No																						
Disable	Off or On	On	Protected																							
Enable	Off	Off or On	No																							
Enable	On	Off or On	Protected																							
69	Diagnostic Switch	Allows setting On/Off for each summary of Diagnostic Status when Enable diagnostic status configuration in UAP Option is set to Enable.	On	W(P)																						
70	Diagnostic Configuration	Allows Categorize for each summary of Diagnostic Status when Enable diagnostic status configuration in UAP Option is set to Enable. 0x08: F:Failure status 0x04: C:Function check status 0x02: O:Out of specification status 0x01: M:Maintenance required status	Refer to Table 9.2.	W(P)																						
71	Find Device	When set a value other than 0, FN510 displays "Squ." on the LCD. The value means the display duration. After displaying, this value returns to 0. Unit: second Range: 0 to 60	0	W																						

Object ID	Attribute ID	Label	Description	Default value	Handling ^{*1}
1. UAPMO block (continued)	102	Diagnostic Status Detail	Detailed information on Diagnostic Status.	Refer to Table 9.2	W
	103	Energy Left	Indicates the number of days of remaining battery life assuming ambient temperature condition as 23 degrees Celsius. Unit: day	---	R
	104	Reset Energy Left	Resets the remaining battery power calculation to restore it to a remaining battery power calculation which is based on new batteries. 0: Continue 1: Reset	0 (reading value is always 0)	W(P)
	105	Power Supply Status	Indicates remaining battery life and power supply of device. 0: line powered 1: battery powered, greater than 75% remaining capacity 2: battery powered, between 25% and 75% remaining capacity 3: battery powered, less than 25% remaining capacity	---	R
	106	Energy Harvest Type	Available to write note into this parameter.	---	W(P)
	107	Power Supply Voltage	Indicates the measured power supply voltage (V).	---	R
	110	Hardware Write Protect	Indicates the status of the hardware write protection switch. 0: Off 1: On	---	R
	111	Antenna Temperature	Indicates the temperature of the FN110.	---	R
	112	Adapter Temperature	Indicates the temperature of the FN510.	---	R
	113	Temperature Unit	Selects the temperature unit to be indicated on Antenna Temperature and Adapter Temperature. 1000: K 1001: °C (default) 1002: °F 1003: °R	°C	W(P)
	135	Other Faults Alert	The On/Off or priority for Other Faults Alert can be set. 1. On/Off setting 0: On, 255: Off (default) 2. Alert report priority: 0 to 15 (default: 15)	1. Off 2. 15	W(P)
	136	Faults Non-compliance Alert	The On/Off or priority for Faults Non-compliance Alert can be set. 1. On/Off setting 0: On, 255: Off (default) 2. Alert report priority: 0 to 15 (default: 15)	1. Off 2. 15	W(P)
	137	Faults Process Influence Alert	The On/Off or priority for Faults Process Influence Alert can be set. 1. On/Off setting 0: On, 255: Off (default) 2. Alert report priority: 0 to 15 (default: 15)	1. Off 2. 15	W(P)
138	Simulation Active Alert	The On/Off or priority for Simulation Active Alert can be set. 1. On/Off setting 0: On, 255: Off (default) 2. Alert report priority: 0 to 15 (default: 15)	1. Off 2. 15	W(P)	
139	Soft Update Incomplete Alert	The On/Off or priority for Soft Update Incomplete Alert can be set. 1. On/Off setting 0: On, 255: Off (default) 2. Alert report priority: 0 to 15 (default: 15)	1. Off 2. 15	W(P)	

Object ID	Attribute ID	Label	Description	Default value	Handling ^{*1}
1. UAPMO block (continued)	140	Power Low Alert	The On/Off or priority for Power Low Alert can be set. 1. On/Off setting 0: On, 255: Off (default) 2. Alert report priority: 0 to 15 (default: 15)	1. Off 2. 15	W(P)
	141	Power Critical Low Alert	The On/Off or priority for Power Critical Low Alert can be set. 1. On/Off setting 0: On, 255: Off (default) 2. Alert report priority: 0 to 15 (default: 15)	1. Off 2. 15	W(P)
	142	Fault Prediction Alert	The On/Off or priority for Fault Prediction Alert can be set. 1. On/Off setting 0: On, 255: Off (default) 2. Alert report priority: 0 to 15 (default: 15)	1. Off 2. 15	W(P)
	143	Environmental Conditions Alert	The On/Off or priority for Environmental Conditions Alert can be set. 1. On/Off setting 0: On, 255: Off (default) 2. Alert report priority: 0 to 15 (default: 15)	1. Off 2. 15	W(P)
	144	Outside Sensor Limits Alert	The On/Off or priority for Outside Sensor Limits Alert can be set. 1. On/Off setting 0: On, 255: Off (default) 2. Alert report priority: 0 to 15 (default: 15)	1. Off 2. 15	W(P)
	145	Out of Service Alert	The On/Off or priority for Out of Service Alert can be set. 1. On/Off setting 0: On, 255: Off (default) 2. Alert report priority: 0 to 15 (default: 15)	1. Off 2. 15	W(P)
	146	Calibration Problem Alert	The On/Off or priority for Calibration Problem Alert can be set. 1. On/Off setting 0: On, 255: Off (default) 2. Alert report priority: 0 to 15 (default: 15)	1. Off 2. 15	W(P)
	147	Faults Sensor or Actuator Alert	The On/Off or priority for Faults Sensor or Actuator Alert can be set. 1. On/Off setting 0: On, 255: Off (default) 2. Alert report priority: 0 to 15 (default: 15)	1. Off 2. 15	W(P)
	148	Faults Electronics Alert	The On/Off or priority for Faults Electronics Alert can be set. 1. On/Off setting 0: On, 255: Off (default) 2. Alert report priority: 0 to 15 (default: 15)	1. Off 2. 15	W(P)
2. UDO block	2	DESCRIPTION	Indicates the version and model information of the downloaded data.	---	R
	3	STATE	Indicates the status of UDO block. 0: Idle 1: Downloading 3: Applying 4: DL Complete 6: DL Error	---	R
	5	MAX_BLOCK_SIZE	Maximum block size. This value is smaller than the maximum data size of APDU.	---	R
	14	LAST_BLOCK_DOWNLOADED	Indicates the last downloaded block number. 0 means that no block has been downloaded.	---	R
	16	ERROR_CODE	Indicates the error codes for DL Error. 0: no Error 1: Timeout 2: Client Abort 64: Apply failure	---	R

Object ID	Attribute ID	Label	Description	Default value	Handling ^{*1}												
3. CO block	1	REVISION	Indicates the revision number such as COMM_ENDPOINT, etc.	---	R												
	2	COMM_ENDPOINT	Indicates the Endpoint information. The following shows the components. 1. Network address of remote endpoint 2. Transport layer port at remote endpoint 3. Object ID at remote endpoint 4. Stale data limit 5. Data publication period 6. Ideal publication phase 7. Publish Auto Retransmit 8. Configuration status	---	W												
	3	COMM_CONTRACT	Indicates the Contract information. The following shows the components. 1. ContractID 2. Contract_Status 3. Actual_Phase	---	R												
	4	PUB_ITEM_MAX	Maximum PUB_ITEM value.	9	R												
	5	PUB_ITEM_NUM	PUB_ITEM number.	0	R												
	6	PUB_ITEM	Indicates the PUB_ITEM information. The following shows the components. 1. ObjectID 2. AttributeID 3. AttributeIndex 4. Size	---	W												
4. TRANSDUCER block	1	Tag Description	Memo field available to write anything.	Transducer	W(P)												
	2	Model	Indicates the model name of the FN510.	---	R												
	3	Serial Number	Indicates the serial number of the FN510.	---	R												
	4	Display Selection	Select PV Value displaying on the integral indicator. Following value can be selected depending on the Sensor Type. <table border="1" data-bbox="608 1151 987 1368"> <thead> <tr> <th>SensorType</th> <th>Value</th> </tr> </thead> <tbody> <tr> <td rowspan="3">DIDO</td> <td>32:BI1(Default)</td> </tr> <tr> <td>33:BI2</td> </tr> <tr> <td>64:BO1</td> </tr> <tr> <td>DI Pulse Count</td> <td>0:AI1(Default)</td> </tr> <tr> <td>4-20mA</td> <td>0:AI1(Default)</td> </tr> <tr> <td>Not Used</td> <td>0:AI1(Default)</td> </tr> </tbody> </table>	SensorType	Value	DIDO	32:BI1(Default)	33:BI2	64:BO1	DI Pulse Count	0:AI1(Default)	4-20mA	0:AI1(Default)	Not Used	0:AI1(Default)	BI1	W(P)
	SensorType	Value															
DIDO	32:BI1(Default)																
	33:BI2																
	64:BO1																
DI Pulse Count	0:AI1(Default)																
4-20mA	0:AI1(Default)																
Not Used	0:AI1(Default)																
5	LCD Intermittent Time	Select the off time of the integral indicator. 0: Continuous mode 1: Intermittent mode (off: 5 seconds, display: 2 seconds) 2: Intermittent mode (off: 10 seconds, display: 2 seconds) 3: Intermittent mode (off: 30 seconds, display: 2 seconds) 4: Intermittent mode (default) (off: 60 seconds, display: 2 seconds) 5: Off mode	Intermittent mode (off: 60 seconds, display: 2 seconds)	W(P)													

Object ID	Attribute ID	Label	Description	Default value	Handling ^{*1}	
4. TRANSDUCER block (continued)	6	LCD Exp Mode	Select the notation of the integral indicator. 0: radix notation (default) 1: exponential notation	radix notation	W(P)	
	7	Wireless Status	Indicates the wireless communication status.	--	R	
			Bits	Contents		Value
			Bit7-3	reserved		---
			Bit2	Contract status (Client/Server)		0: Not established 1: Established
Bit1	Contract status (Publish)	0: Not established 1: Established				
Bit0	Join status	0: Idle 1: Joined				
8	Measurement Rate	Indicates the publish period. Unit: second	---	R		
10	Special Cmd	Special function parameter. 0: Normal mode (default) 1: Deep-sleep mode	Normal mode	W		
11	Sensor Type	Select the type of sensor to be connected to the FN510. 40: DIDO (default) 41: DI Pulse Count 44: 4-20 mA 45: Not Used	DIDO	W(P)		
5. DIS block	1	REVISION	Indicates the revision number such as COMM_ENDPOINT, etc.	---	R	
	2	COMM_ENDPOINT	Indicates the Endpoint information. The following shows the components. 1. Network address of remote endpoint 2. Transport layer port at remote endpoint 3. Object ID at remote endpoint 4. Stale data limit 5. Data publication period 6. Ideal publication phase 7. Publish Auto Retransmit 8. Configuration status	---	W	
	3	SUB_ITEM_MAX	Maximum SUB_ITEM value.	8	R	
	4	SUB_ITEM_NUM	SUB_ITEM number.	0	R	
	5	SUB_ITEM	Indicates the SUB_ITEM information. The following shows the components. 1. ObjectID 2. AttributeID 3. AttributeIndex 4. Size	---	W	

Object ID	Attribute ID	Label	Description	Default value	Handling ^{*1}
20. AI1 block	1	Process Value	Output object of AI1(DI Pulse Count or 4-20 mA). 1. Value: output value of the object. 2. Status: indicates the status of the object's output value.	1. --- 2. ---	R
	2	Block Mode	Select the block's operation status. O/S and Auto can be selected. 1. Target: Specify object mode of the object. 2. Actual: Indicates current mode of the object. 3. Permitted: Indicates the mode selected by Target of the object. 4. Normal: Indicate normal status mode of the object.	1. Auto 2. Auto 3. O/S Auto 4. Auto	W(P)
	3	Concentrator OID	Indicates the Concentrator object value that corresponds to the data update of the PV value.	---	R
	4	Scale	Allows specifying the upper or lower limit for the PV scaling, unit code, etc. When the data of these parameters is rewritten, it is necessary to set the operational mode of the block to O/S (Out of Service). 1. EU at 100%: Indicate the upper limit of the PV value 2. EU at 0%: Indicate the lower limit of the PV value 3. Units Index: Indicate the setting unit used for the PV value 4. Decimal: Indicate the digit number below the decimal point displayed in the integral indicator	1. 100 2. 0 3. % 4. 2	W(P)
	102	Tag Description	A universal parameter to store the comment that describes the tag. Up to 32 characters can be used.	AI1	W(P)
	103	Simulate Switch	A simulation function switch for the object. 1: Disable (default) 2: Enable	Disable	W(P)
	104	Simulate Value	When Simulate Switch is set to Enable, this value is used as the input value for the object. The input value can be changed. When Simulate Switch is set to Disable, the output value of the device connected to mAIn port is used as the input value for the object.	---	W(P)
	105	Sensor Range	Indicates the information about the measurement range. 1. EU at 100%: Indicate the upper limit of the input value 2. EU at 0%: Indicate the lower limit of the input value 3. Units Index: Indicate the unit used for the input value 4. Decimal: Indicate the digit number below the decimal point displayed in the integral indicator	1. 20 2. 4 3. mA 4. 2	R
	106	PV Energy Left Enable	Allows assign the Energy Left to AI1.PV.Value when Sensor Type in TRANSDUCER block is set to "Not Used". 0: Disable (default) 1: Enable		W(P)
	107	Sensor Serial	Indicates the serial number of the sensor, which corresponds to its tag.	---	W(P)
108	Reset Pulse Count	Resets the output value to AI1 when Sensor Type in TRANSDUCER block is set to "DI Pulse Count".	Normal	W(P)	

Object ID	Attribute ID	Label	Description	Default value	Handling ^{*1}
10. BI1 block 11. BI2 block	1	Process Value	Output object of BI1 and BI2. 1. Discrete Value: output value of the object. 0: Off(Open), 255: On(Close) 2. Discrete Status: indicates the status of the object's output value.	1. --- 2. ---	R
	2	Block Mode	Select the block's operation status. O/S and Auto can be selected. 1. Target: Specify object mode of the object. 2. Actual: Indicates current mode of the object. 3. Permitted: Indicates the mode selected by Target of the object. 4. Normal: Indicate normal status mode of the object.	1. Auto 2. Auto 3. O/S Auto 4. Auto	W(P)
	3	Concentrator OID	Indicates the Concentrator object value that corresponds to the data update of the PV value.	---	R
	102	Tag Description	A universal parameter to store the comment that describes the tag. Up to 32 characters can be used.	BI1:BI1 BI2:BI2	W(P)
	103	Simulate Switch	A simulation function switch for the object. 1: Disable (default) 2: Enable	Disable	W(P)
	104	Simulate Value	When Simulate Switch is set to Enable, this value is used as the input value for the object. When Simulate Switch is set to Disable, the output values of the devices connected to IN1/IN2 ports are used as the input values for the objects.	---	W(P)
	105	Options	Option parameter for the object 1. Invert 0: Normal(default), 1: Invert(Inverts the output value)	Normal	W(P)
107	Sensor Serial	Indicates the serial number of the sensor, which corresponds to its tag.	---	W(P)	
30. BO1 block	1	Output Value Binary	Input object of BO1. 1. Discrete Value: input value of the object. 0: Off(Open), 255: On(Close) 2. Discrete Status: indicates the status of the object's output value.	---	W
	2	Block Mode	Select the block's operation status. O/S and Auto can be selected. 1. Target: Specify object mode of the object. 2. Actual: Indicates current mode of the object. 3. Permitted: Indicates the mode selected by Target of the object. 4. Normal: Indicate normal status mode of the object.	1. Auto 2. Auto 3. O/S Auto 4. Auto	W(P)
	4	Read Back Value Binary	Read Back Value of BO1. 1. Discrete Value: Read Back value of the object. 0: Off(Open), 255: On(Close) 2. Discrete Status: indicates the status of the object's output value.	---	R
	5	Concentrator OID	Indicates the Concentrator object value that corresponds to the data update of the Read Back value.	---	R
	102	Tag Description	A universal parameter to store the comment that describes the tag. Up to 32 characters can be used.	BO	W(P)

Object ID	Attribute ID	Label	Description	Default value	Handling *1
30. BO1 Block (continued)	103	Options	Option parameter for the object 1. Invert 0: Normal(default), 1: Invert(Inverts the output value) 2. Fault State supported 0: Off(default), 1: On(Sets Fault Status Value to the input on detection of device failure or Stale Limit) 3. Use Fault State Value 0: Off(default), 1: On(Sets Fault Status Value to the input at startup.)	1.Normal 2.Off 3.Off	W(P)
	104	Fault State Time	If Fault State supported is set to On, the time from the detection of the Fault State until the Fault Status Value is applied is specified by this parameter.	0	W(P)
	105	Fault State Value	If Fault State supported is set to On, this value is used as an input value to the object when Fault State is detected. 1: Off (Open), 255:On(Close)	Off	W(P)
	107	Sensor Serial	Indicates the serial number of the sensor, which corresponds to its tag.	---	W(P)

*1: R: Read only, W: Read and Write, (P): Target of the write protection
 *2: NAMUR NE 107 "Self-Monitoring and Diagnosis of Field Devices"

■ AI Object (AI1 block)

Scale function is valid if the Sensor Type in the TRANSDUCER block is set to 4-20 mA.

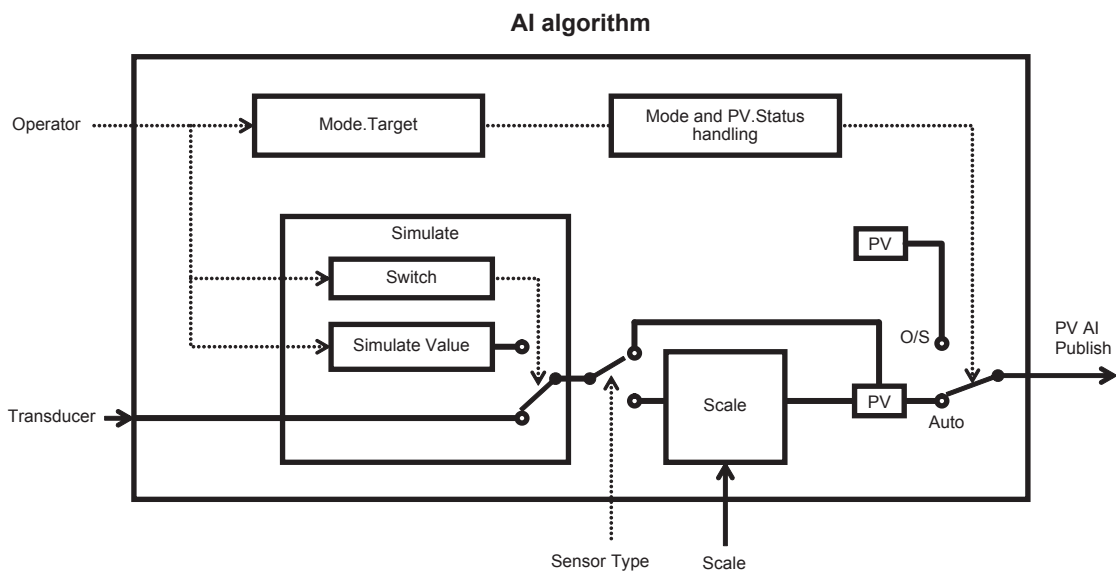

F0901.ai

Figure 9.1 Example schema of Analog Input Object

■ BI Object (BI1/BI2 block)

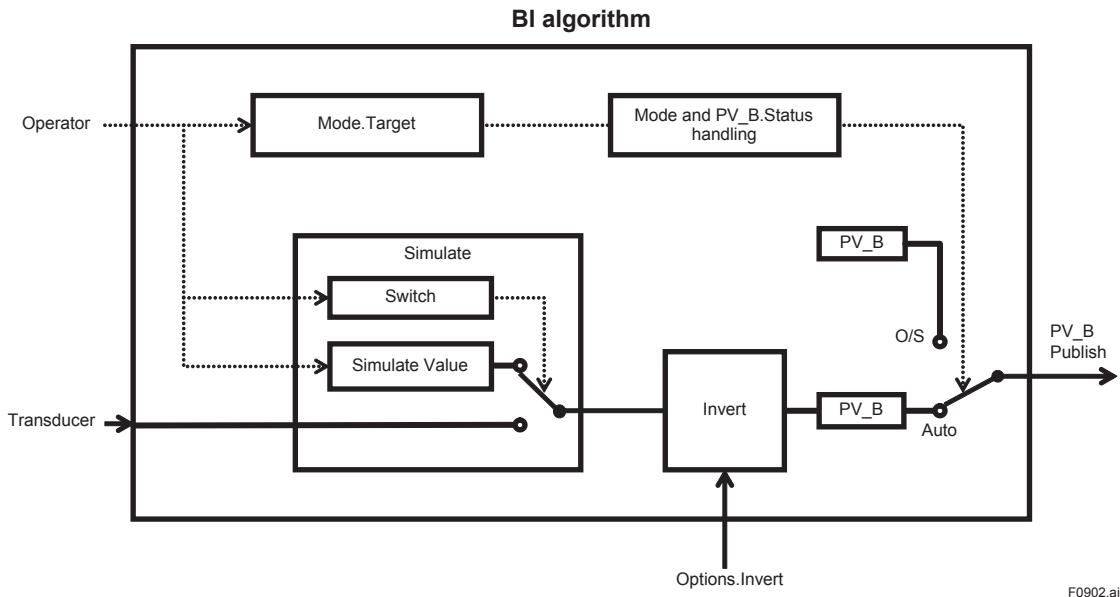

Figure 9.2 Example schema of Binary Input Object

■ BO Object (BO1 block)

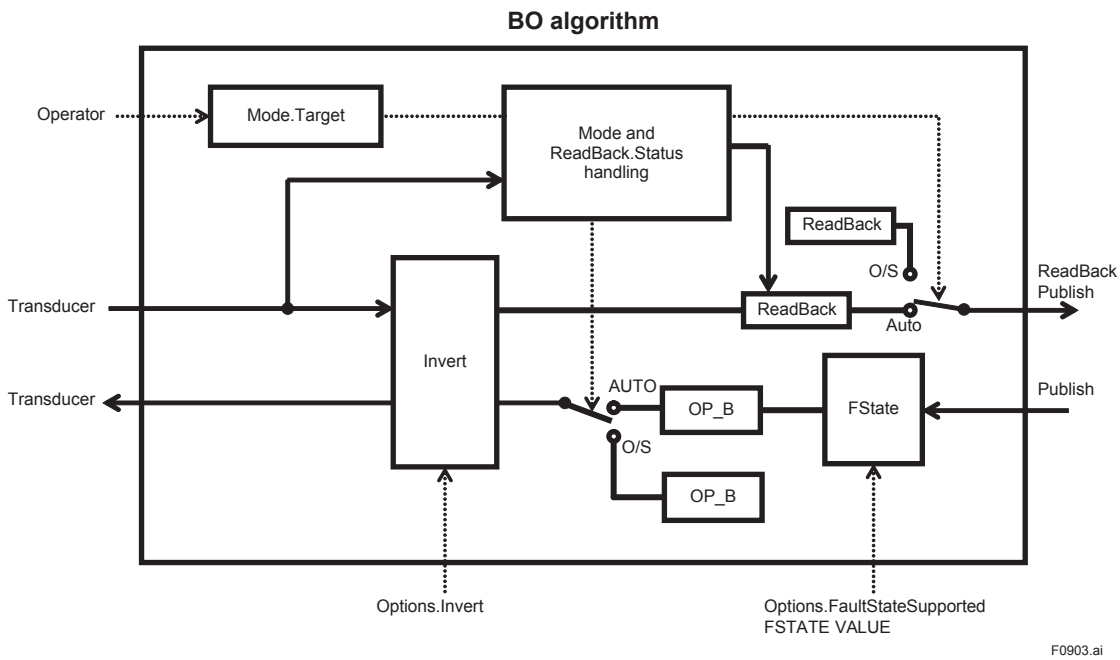

Figure 9.3 Example schema of Binary Output Object

Table 9.2 Diagnostic Status Detail

Bit	Diagnostic Status Detail	Description	Diagnostic status assignment bit	NAMUR NE107 Category *
Diagnostic Status Detail.1				
31	ADAPTER FAIL	FN510 failure	Bit27	F
30	ANTENNA FAIL	FN110 failure	Bit27	F
28	INTERNAL BUS FAIL	Communication failure between FN110 and FN510	Bit27	F
27	SENSOR FAIL	Disconnection or communication error, between the connected device and FN510	Bit26	F
23	BO_STALE_LIMIT_FAIL	Detect Stale Limit	Bit16	F
9	LOWBAT_ALM	Low remaining battery voltage	Bit19	M
8	CRITICAL LOWBAT	Low remaining battery voltage	Bit20	M
7	ADAPTER TEMP HI	FN510 temperature is above +85°C	Bit22	O
6	ADAPTER TEMP LO	FN510 temperature is below -40°C	Bit22	O
5	ANTENNA TEMP HI	FN110 temperature is above +85°C	Bit22	O
4	ANTENNA TEMP LO	FN510 temperature is below -40°C	Bit22	O
1	mA_FAIL	mA value is in the following range, which is not within the specification. 1.0 ≤ mA < 3.6, 21 < mA	Bit26	O
0	mA_OUTSIDE_LIMIT	mA value is in the following range, which is not within the specification. 3.6 ≤ mA < 4.0, 20 < mA ≤ 21	Bit23	O
Diagnostic Status Detail.2				
31	A11 OUT OF SERVICE	A11 O/S Mode	Bit24	C
27	B11 OUT OF SERVICE	B11 O/S Mode	Bit24	C
26	B12 OUT OF SERVICE	B12 O/S Mode	Bit24	C
25	BO1 OUT OF SERVICE	BO1 O/S Mode	Bit24	C
15	A11 SIMULATION ACTIVE	A11 Simulate Mode	Bit17	C
11	B11 SIMULATION ACTIVE	B11 Simulate Mode	Bit17	C
10	B12 SIMULATION ACTIVE	B12 Simulate Mode	Bit17	C

* NAMUR NE 107 "Self-Monitoring and Diagnosis of Field Devices"

10. General Specifications

Please refer to GS 01W03E01-01EN for the latest information.

10.1 Standard Specifications

□ POWER SUPPLY SPECIFICATIONS

Battery:

Dedicated battery pack.
Rated voltage: 7.2 V
Rated capacity: 19 Ah

Battery Pack:

2x primary lithium-thionyl chloride batteries
With battery case (batteries sold separately)

□ PERFORMANCE SPECIFICATIONS

Update Period:

1 to 3600 s selectable*

*: When using the digital output, more than 2 s is accepted.

Battery Characteristics:

Typical battery life when using analog input or digital input is 10 years*¹ or 7 years*² and when using digital output with always on is 3 years*³ or 2 years*¹ in the following conditions.*⁴

- Ambient temperature: 23 ±2°C
- Device role: IO mode
- LCD display: off

*1: Update period: 10 s

*2: Update period: 5 s

*3: Update period : 30 s

*4: Environmental condition such as vibration and the type of connected device may affect the battery life.

Accuracy:

See Table 10.1.

□ FUNCTIONAL SPECIFICATIONS

Input:

See Table 10.1.

Output:

Communication specifications between this product and FN110 are below.

Communication Mode: Half-duplex
communication
(RS485 compliant)

Communication Speed: 9600 bps

Connector: 5-pin round connector dedicated

Cable: Max 20 m (dedicated cable)

Power Supply:

Power supply to the FN110

Supply voltage: 3.5 V

Supply current: 50 mA

Integral Indicator (LCD display):

5-digit numerical and status display. Display contents and display on/off can be controlled with a magnet (not included).

The indicator displays the following information:

Wireless communication status, device status, write protection, sensor data and alarm message

Diagnosis Functions:

Power failures, wired communication failures, firmware internal errors, memory errors, battery alarm, abnormal temperature

Software Download Function:

Software download function permits to update wireless field device software via ISA100 Wireless communication.

□ INSTALLATION ENVIRONMENT

Ambient Temperature Limits:

Operating: -40 to 85°C (altitude up to 3000 m)
-30 to 80°C (LCD visible range)

Storage: -40 to 85°C

Ambient Humidity Limits:

Operating: 0 to 100%RH (non-condensation)

Storage: 0 to 100%RH (non-condensation)

Ambient Temperature Gradient:

Operating: ±10°C/h or less

Storage: ±20°C/h or less

Vibration Resistance:

0.21 mm P-P (10 - 60 Hz), 3G (60 - 2 kHz)

Shock Resistance:

50 G 11 ms

□ REGULATORY COMPLIANCE STATEMENTS

This product satisfies the following standards.

* Please confirm that an installation region fulfills an applicable standard. If additional regulatory information and approvals are required, contact a Yokogawa representative.

CE Conformity:

EMC: EN61326-1 Class A Table 2,
EN55011 Class A
Safety: EN61010-1 (Indoor/Outdoor use)

Canadian Safety Standards:

CAN/CSA-C22.2 No.61010-1
CAN/CSA-C22.2 No.94.1,
CAN/CSA-C22.2 No.94.2
IEC 60529

Degrees of Protection:

IP66, IP67 and Type 4X apply when the connector is properly tightened.

□ PHYSICAL SPECIFICATIONS

Connections:

Refer to “MODEL AND SUFFIX CODES”

Housing Material:

Plastic (Polycarbonate)

Weight:

500 g (without mounting bracket and battery)

Mounting:

2-inch pipe mounting

Table 10.1 Input / Output Function Summary

Function	Item	Specifications
4-20 mA Analog Input (AI) *1	Number of input channels	1
	Input signal	4 to 20 mA DC
	Range	0 to 25 mA
	Internal shunt resistor	10 ohm
	Accuracy	±16 uA
	Temperature coefficient	±3.2 uA/10°C
Digital Input (DI) *1 *2	Number of input channels	2
	Input signal	Dry contact input
	Maximum on resistance	200 Ω
	Minimum off resistance	50 kΩ
	Current value when contact is on	IN1 IN2
Digital Output(DO) *1 *3	Number of output channels	1
	Output signal	Dry contact output
	Maximum load current	125 mA DC
	Maximum load voltage	30 V DC
Pulse Input (PULSE) *1 *2	Number of input channels	1
	Input signal	Dry contact input *2
	Maximum on resistance	200 Ω
	Minimum off resistance	50 kΩ
	Minimum detection time *4	5 ms
	Maximum input frequency	100 Hz
	Counter range	0 to 999999

*1: The input channels are non-isolated and share one common ground.

*2: Do not apply a voltage to a DI or PULSE from the outside.

*3: The digital output terminal is configured as open-drain. The voltage and current applied to a digital output terminal should be within the specified range.

*4: Minimum time required to detect an external contact becomes off.

10.2 Model and Suffix Codes

Model	Suffix Code		Descriptions
FN510		Field Wireless Multi-Function Module
General Specification	Inter module communication	-A1	Digital communication for FN series
	---	-A	Always A
	Housing material	0	Plastic (Polycarbonate)
	Electrical connection	0	Horizontal connection: blind plug, Vertical connection: G 1/2 female *1
		1	Horizontal connection: blind plug, Vertical connection: 1/2 NPT female *1
		2	Horizontal connection: blind plug, Vertical connection: M20 female *1
		6	Horizontal connection: blind plug, Vertical connection: blind plug *2
	Measurement *3	A	One analog input, two digital input, one digital output, one pulse input
	Integral indicator	-D	Digital indicator
	Mounting bracket	J	316 SST 2-inch pipe mounting (for horizontal piping)
		K	316 SST 2-inch pipe mounting (for vertical piping)
		N	None
	---	A	Always A
	---	A	Always A
---	-A	Always A	
---	A	Always A	
Option codes			/ <input type="checkbox"/> Optional specifications

*1: Cable gland is not included. Prepare the cable gland with a flat gasket.

*2: Select when use as a routing device.

*3: Analog input and pulse input are able to use exclusively with other functions.

10.3 Optional Specification (For Explosion Protected Type)

Item	Description	Code
Factory Mutual (FM)	<p>United States</p> <p>FM Intrinsically safe Approval (United States) Applicable Standards: Class 3600:2011, Class 3610:2010, Class 3810:2005, ANSI/ISA-60079-0-2013, ANSI/ISA-60079-11-2014, NEMA 250-2003, ANSI/IEC-60529-2004 (R2011)</p> <p>Intrinsically safe for Class I, II, III, Division 1, Groups C, D, E, F & G, Class I, Zone 0, in Hazardous Locations, AEx ia IIB Enclosure: IP66 and Type 4X, Temperature Class: T4, Amb. Temp. : -40 to 70 °C (-40 to 158 °F) For connection to Class I, II, III, Division 1, Groups A, B, C, D, E, F & G, Class I, Zone 0, in Hazardous Locations, AEx ia IIC</p> <p>Electrical Parameters: Wireless Communication (Connector) Uo = 5.88 V, Io = 483 mA, Po = 779 mW, Co = 5.82 µF, Lo = 25 µH Sensor Input (Terminal 1 to 4) Uo = 5.88 V, Io = 145 mA, Po = 213 mW, Co = 43 µF, Lo = 1.6 mH Sensor Output (Terminal 5, 6) Ui = 30 V, Ii = 200 mA, Pi = 1 W (linear source), Ci = 10 nF, Li = 0 µH Dielectric Strength: 500 V a.c. r.m.s., 1 minute</p>	<p>FS17</p>
	<p>Canada</p> <p>FM Intrinsically safe Approval (Canada) Applicable Standards: CAN/CSA-C22.2 No. 0-10 (R2015), CAN/CSA-C22.2 No. 94.1-07 (R2012), CAN/CSA-C22.2 No. 94.2-07 (R2012), CAN/CSA-C22.2 No. 60079-0:11, CAN/CSA-C22.2 No. 60079-11:14, CAN/CSA-C22.2 No. 60529-05 (R2015), CAN/CSA-C22.2 No. 61010-1-12</p> <p>Ex ia [ja IIC] IIB T4 Ga Intrinsically safe for Class I, II, III, Division 1, Groups C, D, E, F & G Enclosure: IP66 and Type 4X, Temperature Class: T4, Amb. Temp.: -40 to 70 °C (-40 to 158°F) For connection to Class I, II, III, Division 1, Groups A, B, C, D, E, F & G</p> <p>Electrical Parameters: Wireless Communication (Connector) Uo = 5.88 V, Io = 483 mA, Po = 779 mW, Co = 5.82 µF, Lo = 25 µH Sensor Input (Terminal 1 to 4) Uo = 5.88 V, Io = 145 mA, Po = 213 mW, Co = 43 µF, Lo = 1.6 mH Sensor Output (Terminal 5, 6) Ui = 30 V, Ii = 200 mA, Pi = 1 W (linear source), Ci = 10 nF, Li = 0 µH Dielectric Strength: 500 V a.c. r.m.s., 1 minute</p>	<p>CS17</p>
ATEX	<p>ATEX Intrinsically safe Approval Applicable Standards: EN 60079-0:2012/A11:2013, EN 60079-11:2012, EN 60079-28:2015</p> <p>Certificate: FM 15ATEX0071X II 1 G Ex ia op is [ja IIC] IIB T4 Ga Degrees of protection: IP66 according to EN 60529:1991/A1:2000/A2:2013 Amb. Temp. (Tamb): -40 to 70 °C (-40 to 158 °F)</p> <p>Electrical Parameters: Wireless Communication (Connector) Uo = 5.88 V, Io = 483 mA, Po = 779 mW, Co = 5.82 µF, Lo = 25 µH Sensor Input (Terminal 1 to 4) Uo = 5.88 V, Io = 145 mA, Po = 213 mW, Co = 43 µF, Lo = 1.6 mH Sensor Output (Terminal 5, 6) Ui = 30 V, Ii = 200 mA, Pi = 1 W (linear source), Ci = 10 nF, Li = 0 µH Dielectric Strength: 500 V a.c. r.m.s., 1 minute</p>	<p>KS27</p>
IECEX	<p>IECEX Intrinsically safe Approval Applicable Standards: IEC60079-0:2011, IEC60079-11:2011, IEC60079-28:2015</p> <p>Certificate: IECEX FMG 15.0042X Ex ia op is [ja IIC] IIB T4 Ga Degrees of protection: IP66 according to IEC60529:2013 Amb. Temp. (Tamb): -40 to 70 °C (-40 to 158 °F)</p> <p>Electrical Parameters: Wireless Communication (Connector) Uo = 5.88 V, Io = 483 mA, Po = 779 mW, Co = 5.82 µF, Lo = 25 µH Sensor Input (Terminal 1 to 4) Uo = 5.88 V, Io = 145 mA, Po = 213 mW, Co = 43 µF, Lo = 1.6 mH Sensor Output (Terminal 5, 6) Ui = 30 V, Ii = 200 mA, Pi = 1 W (linear source), Ci = 10 nF, Li = 0 µH Dielectric Strength: 500 V a.c. r.m.s., 1 minute</p>	<p>SS27</p>

10.4 Optional Specifications

Item	Description	Code
Protection cap *	Metal waterproof cap	CP
Wired tag plate	316 SST tag plate wired onto module	N4

*: When protection cap is not specified, dust-cap is attached.

10.5 Optional Accessories

Item	Parts Number	Description
Battery pack assembly	F9090FD *1	Battery case, Lithium-thionyl chloride batteries *2 2 pieces
Batteries *3	F9915NR	Lithium-thionyl chloride batteries *2, 2pieces
Battery case	F9090GD *4	Battery case only
Magnet	F9840PA	For magnet switch operation

*1: If you need F9090FC, please purchase F9090FD. F9090FD is a set of F9090FC and instruction manual.

*2: Tadiran TL-5930/S

*3: Alternatively, Tadiran SL-2780/S, TL-5930/S or VITZROCELL SB-D02 batteries can be purchased from your local distributor.

*4: If you need F9090GC, please purchase F9090GD. F9090GD is a set of F9090GC and instruction manual.

10.6 Dimensions

□ 2-inch pipe mounting (for horizontal piping)

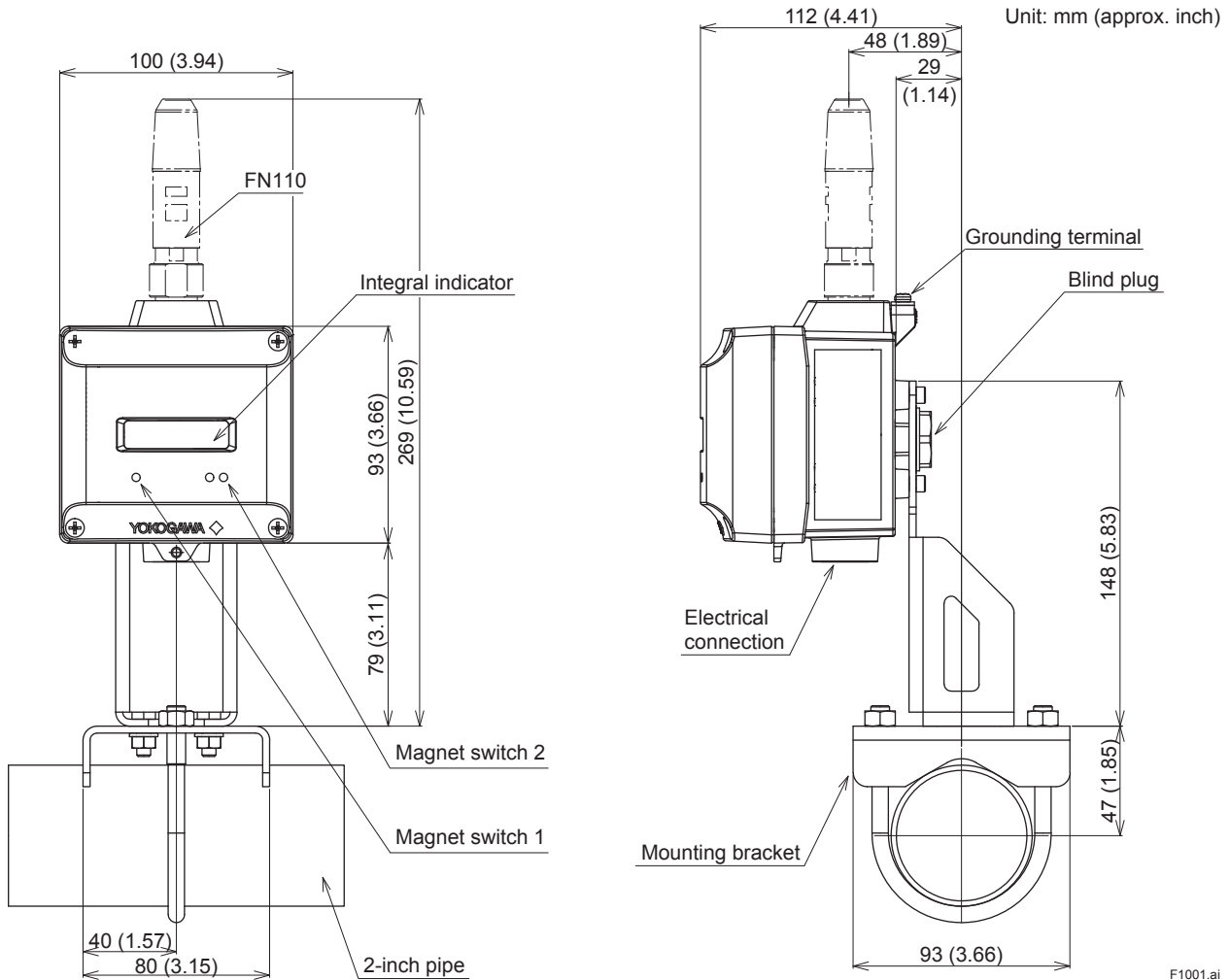





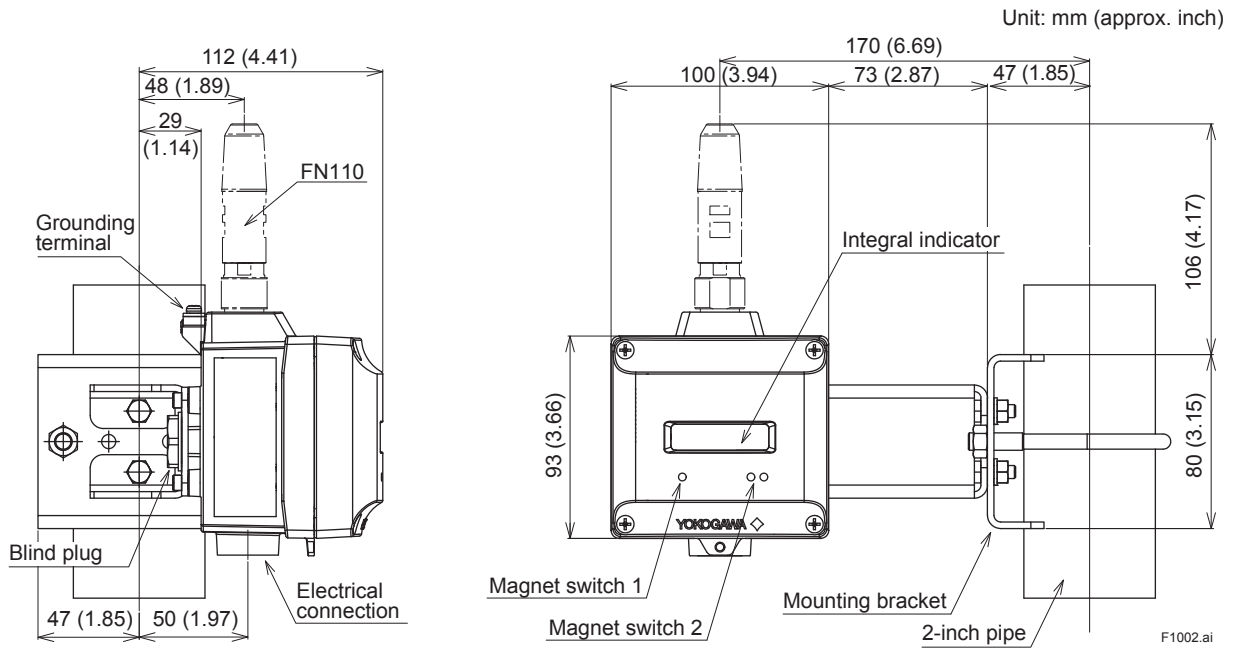





















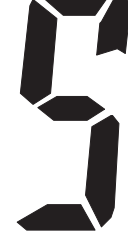









F1001.ai

□ 2-inch pipe mounting (for vertical piping)

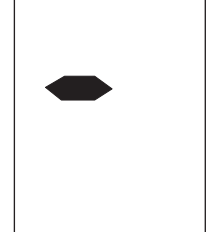

10.7 LCD Display Character List

A	B	C	D	E	F	G	H
							
I	J	K	L	M	N	O	P
							
Q	R	S	T	U	V	W	X
							
Y	Z	1	2	3	4	5	6
							
7	8	9	0	.(Period)	-(Minus)		
							

F1009.ai

Revision Information

Title : FN510 Field Wireless Multi-Function Module

Manual No. : IM 01W03E01-01EN

Edition	Date	Page	Revised item
1st	Dec. 2014	—	New Publication
2nd	May 2016	—	Add FM Approvals (United States and Canada) and IECEx Certification.
3rd	July 2016	—	Add ATEX Certification and Canadian Safety Standards