

# digitalYEWFLO Series Vortex Flowmeter Installation Manual

IM 01F06A01-01EN

vigilantplant.®



Integral Type  
Vortex Flowmeter



Remote Type  
Vortex Flowmeter Detector



Remote Type  
Vortex Flow Converter

1. INTRODUCTION	1
2. HANDLING PRECAUTIONS	2
3. INSTALLATION	3
4. WIRING	4
5. BASIC OPERATING PROCEDURES (DISPLAY)	5
6. PARAMETERS	6
7. COMMUNICATION (BRIN / HART)	7
8. OPERATION	8
9. ERRORS AND COUNTERMEASURES FOR DISPLAY UNIT AND BRIN PROTOCOL	9
10. EXPLOSION PROTECTED TYPE INSTRUMENT	10
11. COMMUNICATION (FIELDBUS)	11
12. EXPLOSION PROTECTED TYPE INSTRUMENT FOR FIELDBUS COMMUNICATION TYPE	12
13. PED (PRESSURE EQUIPMENT DIRECTIVE)	13

## INSTALLATION AND OPERATING PRECAUTIONS FOR TIIS FLAMEPROOF EQUIPMENT

This book is a manual that extract the contents related to the installation and wiring from the manuals below.  
There are some differences, but does not affect the safety of the product performance and use.

Document No.	Title
IM 01F06A00-01EN	digitalYEWFLO Series Vortex Flowmeter
IM 01F06F00-01EN	digitalYEWFLO Series Vortex Flowmeter FOUNDATION Fieldbus Communication Type

# digitalYEWFO Series Vortex Flowmeter Installation Manual

IM 01F06A01-01EN 2nd Edition

## Contents

<b>1. INTRODUCTION.....</b>	<b>3</b>	<b>8. OPERATION .....</b>	<b>31</b>
1.1 Using This Instrument Safely.....	4	8.1 Adjustment.....	31
1.2 Warranty .....	5	8.1.1 Zero Adjustment .....	31
1.3 ATEX Documentation.....	6	8.1.2 Span Adjustment .....	31
<b>2. HANDLING PRECAUTIONS .....</b>	<b>7</b>	8.1.3 Loop Test .....	31
2.1 Checking Model and Specifications .....	7	8.1.4 Totalizer Start and Totalizer Reset.....	32
2.2 Transportation and Storage Precautions .....	7	8.1.5 Setting of Pulse Output (Scaling) .....	32
<b>3. INSTALLATION .....</b>	<b>8</b>	8.1.6 Setting of Burnout Switch .....	32
3.1 Installation Precautions.....	8	8.1.7 Setting of Write Protect Switch .....	33
3.2 Piping Precautions.....	8	8.1.8 Power Failure .....	33
3.3 Maintenance of Piping .....	12	<b>8.2 Adjustment for Manual Mode.....</b>	<b>33</b>
3.4 Cryogenic and High Process Temperature Version Insulation .....	13	8.2.1 Low Cut Adjustment .....	33
3.5 Mounting Procedures .....	13	8.2.2 Zero Tuning .....	33
<b>4. WIRING .....</b>	<b>17</b>	<b>9. ERRORS AND COUNTERMEASURES FOR DISPLAY UNIT AND BRAIN PROTOCOL .....</b>	<b>35</b>
4.1 Load Resistance of Output Condition .....	17	9.1 Large Errors or Unstable Output.....	35
4.2 Selection of Wires .....	18	9.2 The Indication Goes to Zero at Certain Time.....	35
4.3 Connection.....	18	9.3 No Output When The Fluid is Flowing .....	36
4.4 Connection of DYC Remote Type Signal Cable.....	21	9.4 Output is Indicated at Zero Flow.....	37
4.5 End Processing Method of DYC Remote Type Signal Cable .....	22	9.5 Multi-Variable Type (/MV) .....	38
4.5.1 For Remote Type Vortex Flowmeter (DY-N).....	22	<b>10. EXPLOSION PROTECTED TYPE INSTRUMENT.....</b>	<b>39</b>
4.5.2 For DYA Remote Type Converter.....	23	10.1 ATEX .....	39
4.6 Wiring Procedures and Precautions .....	24	10.2 FM.....	43
4.7 Grounding .....	25	10.3 IECEx .....	47
<b>5. BASIC OPERATING PROCEDURES (DISPLAY).....</b>	<b>26</b>	10.4 CSA .....	50
5.1 Display Configuration.....	26	10.5 TIIS .....	53
<b>6. PARAMETERS .....</b>	<b>27</b>	<b>11. COMMUNICATION (FIELD BUS) .....</b>	<b>54</b>
6.1 digitalYEWFO Parameters .....	27	11.1 Amplifier for Fieldbus Communication Type ..	54
6.2 Parameter Configuration .....	27	11.2 Connection of Devices.....	54
6.3 Self-Diagnostic (Error Code List) .....	28	11.3 Host Setting .....	55
<b>7. COMMUNICATION (BRAIN / HART).....</b>	<b>29</b>	11.4 Power-on of digitalYEWFO and Bus.....	56
7.1 Connection Method for the BT200.....	29	11.5 Generation of Alarm .....	56
7.2 Connection Method for the HART Configuration Tool .....	30	11.5.1 Indication of Alarm .....	56
		11.5.2 Alarms and Events .....	58
		11.6 Simulation Function.....	58

---

<b>12. EXPLOSION PROTECTED TYPE INSTRUMENT FOR FIELDBUS COMMUNICATION TYPE .....</b>	<b>59</b>
12.1 ATEX .....	59
12.2 FM.....	64
12.3 IECEX .....	67
<b>13. PED (PRESSURE EQUIPMENT DIRECTIVE).....</b>	<b>69</b>
<b>INSTALLATION AND OPERATING PRECAUTIONS FOR TIIS FLAMEPROOF EQUIPMENT .....</b>	<b>70</b>

**Revision Information**

# 1. INTRODUCTION

Thank you for purchasing the digital YEW FLO Series Vortex flowmeter.

This manual provides the basic guidelines for installation and wiring procedures of integral type vortex flowmeter, remote type vortex flow detector, and remote type vortex flow converter through the communication tool.

It does not provide the product specific functional specifications and explanations, maintenance, troubleshooting. For the items which are not covered in this manual, read the applicable user's manuals on the front page. These manuals can be downloaded from the website of Yokogawa. To ensure correct use of the instrument, read these manuals thoroughly and fully understand how to operate the instrument before operating it.

Website address: <http://www.yokogawa.com/fld/doc/>

## ■ Regarding This Manual

- This manual should be provided to the end user.
- The contents of this manual may be changed without prior notice.
- All rights are reserved. No part of this manual may be reproduced in any form without Yokogawa's written permission.
- Yokogawa makes no warranty of any kind with regard to this material, including, but not limited to, implied warranties of merchantability and suitability for a particular purpose.
- All reasonable effort has been made to ensure the accuracy of the contents of this manual. However, if any errors or omissions are found, please inform Yokogawa.
- The specifications covered by this manual are limited to those for the standard type under the specified model number break-down and do not cover custom-made instruments.
- Please note that this manual may not be revised for any specification changes, construction changes or operating part changes that are not considered to affect function or performance.
- Yokogawa assumes no responsibilities for this product except as stated in the warranty.
- If the customer or any third party is harmed by the use of this product, Yokogawa assumes no responsibility for any such harm owing to any defects in the product which were not predictable, or for any indirect damages.

## ■ Safety and Modification Precautions

- The following general safety precautions must be observed during all phases of operation, service, and repair of this instrument. Failure to comply with these precautions or with specific WARNINGS given elsewhere in this manual violates safety standards of design, manufacture, and intended use of the instrument. Yokogawa assumes no liability for the customer's failure to comply with these requirements. If this instrument is used in a manner not specified in this manual, the protection provided by this instrument may be impaired.
- The following safety symbol marks are used in this manual and instrument.



### WARNING

A WARNING sign denotes a hazard. It calls attention to procedure, practice, condition or the like, which, if not correctly performed or adhered to, could result in injury or death of personnel.



### CAUTION

A CAUTION sign denotes a hazard. It calls attention to procedure, practice, condition or the like, which, if not correctly performed or adhered to, could result in damage to or destruction of the product.



### IMPORTANT

An IMPORTANT sign denotes that attention is required to avoid damage to the instrument or system failure.



### NOTE

A NOTE sign denotes information necessary for essential understanding of operation and features.

## 1.1 Using This Instrument Safely

### (1) Installation



#### WARNING

- Installation of the vortex flowmeter must be performed by expert engineer or skilled personnel. No operator shall be permitted to perform procedures relating to installation.
- The vortex flowmeter must be installed within the specification conditions.
- The vortex flowmeter is a heavy instrument. Be careful that no damage is caused to personnel through accidentally dropping it, or by exerting excessive force on the vortex flowmeter. When moving the vortex flowmeter, always use a trolley and have at least two people carry it.
- When the vortex flowmeter is processing hot fluids, the instrument itself may become extremely hot. Take sufficient care not to get burnt.
- Where the fluid being processed is a toxic substance, avoid contact with the fluid and avoid inhaling any residual gas, even after the instrument has been taken off the piping line for maintenance and so forth.
- Do not apply excessive weight, for example, a person stepping on the vortex flowmeter.
- Do not open the cover in wet weather or humid environment. When the cover is open, stated enclosure protection is not applicable.
- When opening the cover, wait for more than 2 minutes after turning off the power.
- All procedures relating to installation must comply with the electrical code of the country where it is used.

### (2) Wiring



#### WARNING

- The wiring of the vortex flowmeter must be performed by expert engineer or skilled personnel. No operator shall be permitted to perform procedures relating to wiring.
- When connecting the wiring, check that the supply voltage is within the range of the voltage specified for this instrument before connecting the power cable. In addition, check that no voltage is applied to the power cable before connecting the wiring.

### (3) Operation



#### WARNING

- Do not open the cover in wet weather or humid environment. When the cover is open, stated enclosure protection is not applicable.
- When opening the cover, wait for more than 2 minutes after turning off the power.

### (4) Maintenance



#### WARNING

- Maintenance of the vortex flowmeter should be performed by the trained personnel having knowledge of safety standard. No operator shall be permitted to perform any operations relating to maintenance.
- Do not open the cover in wet weather or humid environment. When the cover is open, stated enclosure protection is not applicable.
- When opening the cover, wait for more than 2 minutes after turning off the power.
- Always conform to maintenance procedures outlined in this manual. If necessary, contact Yokogawa.
- When maintaining the instrument, read user's manual as listed on the front page. If necessary, contact Yokogawa.

**(5) Explosion Protected Type Instrument**



**WARNING**

- The instruments are products which have been certified as explosion protected type instruments. Strict limitations are applied to the structures, installation locations, external wiring work, maintenance and repairs, etc. of these instruments. Sufficient care must be taken, as any violation of the limitations may cause dangerous situations. Be sure to read Chapter 10 “EXPLOSION PROTECTED TYPE INSTRUMENT” or Chapter 12 “EXPLOSION PROTECTED TYPE INSTRUMENT FOR FIELDBUS COMMUNICATION TYPE” before handling the instruments. For TIIS flameproof type instruments, be sure to read “INSTALLATION AND OPERATING PRECAUTIONS FOR TIIS FLAMEPROOF EQUIPMENT” at the end of this manual.
- Only trained persons use this instrument in the industrial location.
- Take care not to generate mechanical spark when access to the instrument and peripheral devices in hazardous locations.

**(6) European Pressure Equipment Directive (PED)**



**WARNING**

- When using the instrument in compliance with PED, be sure to read Chapter 13 “PED (PRESSURE EQUIPMENT DIRECTIVE)” before use.

**(7) Modification**

Yokogawa will not be liable for malfunctions or damage resulting from any modification made to this instrument by the customer.

**(8) Product Disposal**

The instrument should be disposed of in accordance with local and national legislation/ regulations.

**(9) Authorized Representative in EEA**

In relation to the CE Marking, The authorized representative for this product in the EEA (European Economic Area) is:  
Yokogawa Europe B.V.  
Euroweg 2, 3825 HD Amersfoort,  
The Netherlands

**(10) CE Marking**

CE Marking is indicated on the name plate of non-explosion protected type and ATEX explosion protected type.

**1.2 Warranty**

- The terms of this instrument that are guaranteed are described in the quotation. We will make any repairs that may become necessary during the guaranteed term free of charge.
- Please contact our sales office if this instrument requires repair.
- If the instrument is faulty, contact us with concrete details about the problem and the length of time it has been faulty, and state the model and serial number. We would appreciate the inclusion of drawings or additional information.
- The results of our examination will determine whether the meter will be repaired free of charge or on an at-cost basis.

**■ The guarantee will not apply in the following cases:**

- Damage due to negligence or insufficient maintenance on the part of the customer.
- Problems or damage resulting from handling, operation or storage that violates the intended use and specifications.
- Problems that result from using or performing maintenance on the instrument in a location that does not comply with the installation location specified by Yokogawa.
- Problems or damage resulting from repairs or modifications not performed by Yokogawa or someone authorized by Yokogawa.
- Problems or damage resulting from inappropriate reinstallation after delivery.
- Problems or damage resulting from disasters such as fires, earthquakes, storms, floods, or lightning strikes and external causes.

**■ Trademarks:**

- ‘digitalYEWFLO’, ‘DY’, ‘DYA’, ‘DYC’, and ‘BRAIN TERMINAL’ are registered trademarks of Yokogawa Electric Corporation. Company names and product names used in this material are registered trademarks or trademarks of their respective owners.
- In this manual, trademarks or registered trademarks are not marked with ™ or ®.

### 1.3 ATEX Documentation

This is only applicable to the countries in European Union.

- GB** All instruction manuals for ATEX Ex related products are available in English, German and French. Should you require Ex related instructions in your local language, you are to contact your nearest Yokogawa office or representative.
- SK** Všetky návody na obsluhu pre prístroje s ATEX Ex sú k dispozícii v jazyku anglickom, nemeckom a francúzskom. V prípade potreby návodu pre Ex-prístroje vo Vašom národnom jazyku, skontaktujte prosím miestnu kanceláriu firmy Yokogawa.
- DK** Alle brugervejledninger for produkter relateret til ATEX Ex er tilgængelige på engelsk, tysk og fransk. Skulle De ønske yderligere oplysninger om håndtering af Ex produkter på eget sprog, kan De rette henvendelse herom til den nærmeste Yokogawa afdeling eller forhandler.
- CZ** Všechny uživatelské příručky pro výrobky, na něž se vztahuje nevybušné schválení ATEX Ex, jsou dostupné v angličtině, němčině a francouzštině. Požadujete-li pokyny týkající se výrobků s nevybušným schválením ve vašem lokálním jazyku, kontaktujte prosím vaši nejbližší reprezentační kancelář Yokogawa.
- I** Tutti i manuali operativi di prodotti ATEX contrassegnati con Ex sono disponibili in inglese, tedesco e francese. Se si desidera ricevere i manuali operativi di prodotti Ex in lingua locale, mettersi in contatto con l'ufficio Yokogawa più vicino o con un rappresentante.
- LT** Visos gaminių ATEX Ex kategorijos Eksploatavimo instrukcijos teikiami anglų, vokietėių ir prancūzų kalbomis. Norėdami gauti prietaisų Ex dokumentaciją kitomis kalbomis susisiekite su artimiausiu bendrovės "Yokogawa" biuru arba atstovu.
- E** Todos los manuales de instrucciones para los productos antiexplosivos de ATEX están disponibles en inglés, alemán y francés. Si desea solicitar las instrucciones de estos artículos antiexplosivos en su idioma local, deberá ponerse en contacto con la oficina o el representante de Yokogawa más cercano.
- LV** Visas ATEX Ex kategorijas izstrādājumu Lietošanas instrukcijas tiek piegādātas angļu, vācu un franču valodās. Ja vēlaties saņemt Ex ierīšu dokumentāciju citā valodā, Jums ir jāsazinās ar firmas Jokogava (Yokogawa) tuvāko ofisu vai pārstāvi.
- NL** Alle handleidingen voor producten die te maken hebben met ATEX explosiebeveiliging (Ex) zijn verkrijgbaar in het Engels, Duits en Frans. Neem, indien u aanwijzingen op het gebied van explosiebeveiliging nodig hebt in uw eigen taal, contact op met de dichtstbijzijnde vestiging van Yokogawa of met een vertegenwoordiger.
- EST** Kõik ATEX Ex toodete kasutamisujuhendid on esitatud inglise, saksa ja prantsuse keeles. Ex seadmete muukeelse dokumentatsiooni saamiseks pöörduge lähima lokagava (Yokogawa) kontori või esindaja poole.
- SF** Kaikkien ATEX Ex -tyyppisten tuotteiden käyttöohjeet ovat saatavilla englannin-, saksan- ja ranskankielisinä. Mikäli tarvitsette Ex -tyyppisten tuotteiden ohjeita omalla paikallisella kielellänne, ottakaa yhteyttä lähimpään Yokogawa-toimistoon tai -edustajaan.
- PL** Wszystkie instrukcje obsługi dla urządzeń w wykonaniu przeciwybuchowym Ex, zgodnych z wymaganiami ATEX, dostępne są w języku angielskim, niemieckim i francuskim. Jeżeli wymagana jest instrukcja obsługi w Państwa lokalnym języku, prosimy o kontakt z najbliższym biurem Yokogawy.
- P** Todos os manuais de instruções referentes aos produtos Ex da ATEX estão disponíveis em Inglês, Alemão e Francês. Se necessitar de instruções na sua língua relacionadas com produtos Ex, deverá entrar em contacto com a delegação mais próxima ou com um representante da Yokogawa.
- SLO** Vsi predpisi in navodila za ATEX Ex sorodni pridelki so pri roki v angleščini, nemščini ter francoščini. Če so Ex sorodna navodila potrebna v vašem tukejnem jeziku, kontaktirajte vaš najbliži Yokogawa office ili predstavnika.
- F** Tous les manuels d'instruction des produits ATEX Ex sont disponibles en langue anglaise, allemande et française. Si vous nécessitez des instructions relatives aux produits Ex dans votre langue, veuillez bien contacter votre représentant Yokogawa le plus proche.
- H** Az ATEX Ex műszerek gépkönyveit angol, német és francia nyelven adjuk ki. Amennyiben helyi nyelven kéri az Ex eszközök leírásait, kérjük keressék fel a legközelebbi Yokogawa irodát, vagy képviselőtet.
- D** Alle Betriebsanleitungen für ATEX Ex bezogene Produkte stehen in den Sprachen Englisch, Deutsch und Französisch zur Verfügung. Sollten Sie die Betriebsanleitungen für Ex-Produkte in Ihrer Landessprache benötigen, setzen Sie sich bitte mit Ihrem örtlichen Yokogawa-Vertreter in Verbindung.
- BG** Всички упътвания за продукти от серията ATEX Ex се предлагат на английски, немски и френски език. Ако се нуждаете от упътвания за продукти от серията Ex на родния ви език, се свържете с най-близкия офис или представителство на фирма Yokogawa.
- S** Alla instruktionsböcker för ATEX Ex (explosionssäkra) produkter är tillgängliga på engelska, tyska och franska. Om Ni behöver instruktioner för dessa explosionssäkra produkter på annat språk, skall Ni kontakta närmaste Yokogawakontor eller representant.
- RO** Toate manualele de instructiuni pentru produsele ATEX Ex sunt in limba engleza, germana si franceza. In cazul in care doriti instructiunile in limba locala, trebuie sa contactati cel mai apropiat biuru sau reprezentant Yokogawa.
- GR** Όλα τα εγχειρίδια λειτουργίας των προϊόντων με ATEX Ex διατίθενται στα Αγγλικά, Γερμανικά και Γαλλικά. Σε περίπτωση που χρειάζεστε οδηγίες σχετικά με Ex στην τοπική γλώσσα παρακαλούμε επικοινωνήστε με το πλησιέστερο γραφείο της Yokogawa ή αντιπρόσωπο της.
- M** Il-manwali kollha ta' I-istruzzjonijiet ghal prodotti marbuta ma' ATEX Ex huma disponibbli bi-Ingliż, bi-Germaniż u bi-Franċiż. Jekk tkun teħtiegħ struzzjonijiet marbuta ma' Ex fil-lingwa lokali tiegħek, għandek tikkuntattja lill-eqreb rappreżentant jew ufficiċju ta' Yokogawa.

# 2. HANDLING PRECAUTIONS

The digitalYEWFLO Series Vortex Flowmeter are thoroughly tested at the factory before shipment. When these instruments are delivered, perform a visual check to ascertain that no damage occurred during shipment.

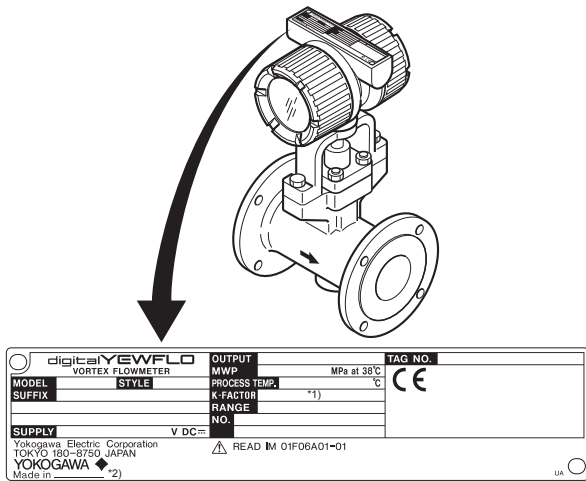
This section describes important cautions in handling these instruments. Read carefully before using them.

If you have any problems or questions, contact your nearest YOKOGAWA service center or sales representative.

## 2.1 Checking Model and Specifications

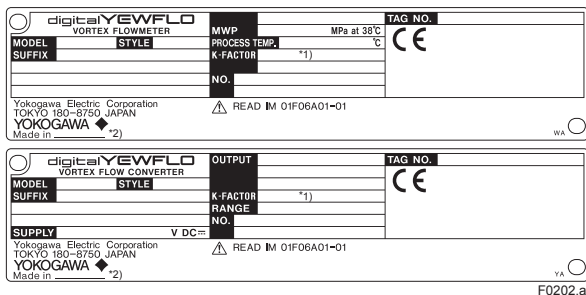
The model code and specifications are found on the name plate located on the outside of the case. Check that the model code and specifications match what you have ordered.

Be sure you have your model number and serial number available when contacting Yokogawa.



F0201.ai

Figure 2.1(a) Example of Name Plate for Integral Type



F0202.ai

Figure 2.1(b) Example of Name Plate for Remote Type

\*1): K factor at + 15°C

\*2): The product - producing country.

## 2.2 Transportation and Storage Precautions

If the instrument is to be stored for a long period of time after delivery, observe the following points.

- (1) The instrument should be stored in its original packing condition in the storage location.
- (2) Select a storage location that fulfils the following conditions:

- A place where it will not be exposed to rain or water
- A place subject to minimal vibrations or shocks
- Temperature and humidity levels should be as follows:

Temperature: -40 to +80°C

Humidity: 5 to 100% RH (no condensation)

The preferred ambient temperature and humidity levels are +25°C and approximately 65% RH.

- (3) If the digitalYEWFLO vortex flowmeter is transferred to the installation site and stored without being installed, its performance may be impaired due to the infiltration of rainwater and so forth. Be sure to install and wire the digitalYEWFLO vortex flowmeter as soon as possible after transferring it to the installation location.
- (4) The vortex flowmeter is a heavy instrument. Be careful that no damage is caused to personnel through accidentally dropping it, or by exerting excessive force on the vortex flowmeter. When moving the vortex flowmeter, always use a trolley and have at least two people carry it.



# 3. INSTALLATION

## WARNING

This instrument must be installed by expert engineer or skilled personnel. The procedures described in this chapter are not permitted for operators.

### 3.1 Installation Precautions

#### (1) Ambient Temperature

Avoid an area which has wide temperature variations. When the installation area is subjected to heat radiation from process plant, ensure adequate heat prevention or ventilation.

#### (2) Atmospheric Conditions

Avoid installing the vortex flowmeter in a corrosive atmosphere. When the vortex flowmeter must be installed in a corrosive atmosphere, adequate ventilation must be provided

#### (3) Mechanical Shock or Vibration

The vortex flowmeter is of sturdy construction, but select an area subject to minimize mechanical vibration or impact shock. If the flowmeter is subject to vibrations, it is recommended that pipeline supports to be provided as shown in Figure 3.1.

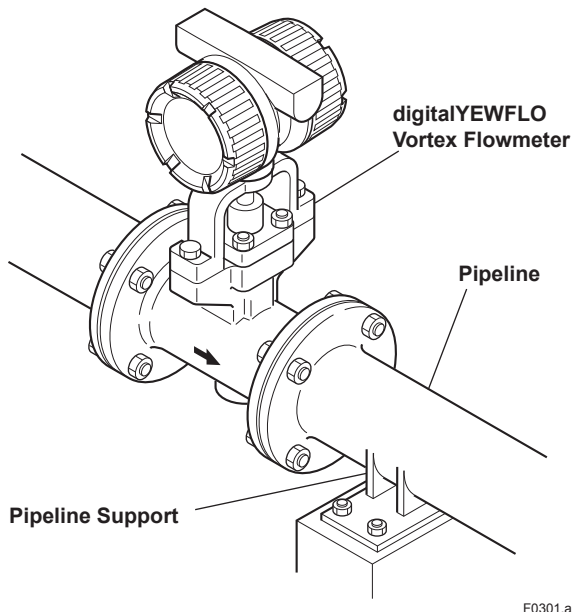


Figure 3.1 Example of Pipeline Support

#### (4) Precautions Regarding Piping

- (a) Ensure that the process connector bolts are tightened firmly.
- (b) Ensure that no leak exists in the process connection pipeline.
- (c) Do not apply a pressure higher than the specified maximum working pressure.
- (d) Do not loosen or tighten the flange mounting bolts when the assembly is pressurized.
- (e) Handle the vortex flowmeter carefully when measuring dangerous liquids, so that the liquids do not splash into eyes or on face. When using dangerous gases, be careful not to inhale them.

#### (5) Other Considerations

- Choose a location where is sufficient clearance around digitalYEWFLO exist to allow such work as routine inspections.
- Choose a location that ensures easy wiring and piping.

### 3.2 Piping Precautions

#### ■ Straight Pipe Length and Recommendations

Read Table 3.1 about Valve Position and Straight Pipe Length and so on.

#### ● Piping support

Typical vibration immunity level is 1G for normal piping condition. Piping support should be fixed in case of over 1G vibration level.

#### ● Installation direction

If a pipe is always filled with liquids, the pipe can be installed vertically or at inclined angle.

#### ● Adjacent pipes

The process pipeline inner diameter should be larger than the digitalYEWFLO inner diameter. Use the following adjacent pipe.

Model Code	Adjacent Pipe
DY015 up to DY050 DY025/R1 up to DY080/R1 DY040/R2 up to DY100/R2	Sch40 or larger inner diameter than Sch40
DY080 up to DY400 DY100/R1 up to DY200/R1 DY150/R2 up to DY200/R2	Sch80 or larger inner diameter than Sch80

**Table 3.1 (a) Straight pipe length and recommendations (1)**

D: Nominal diameter (mm)

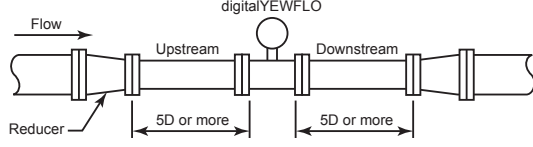
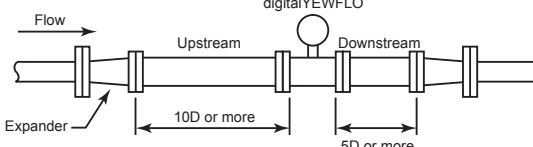
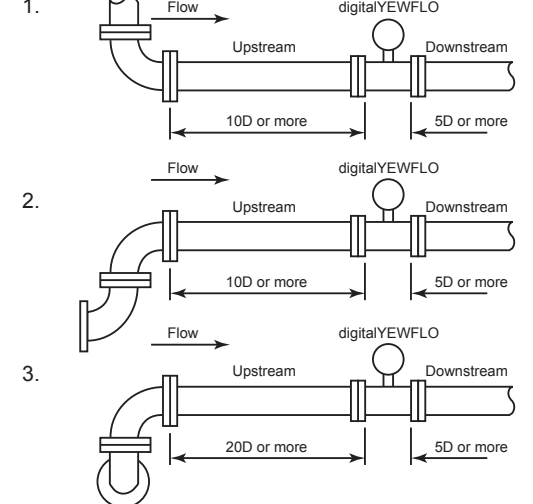
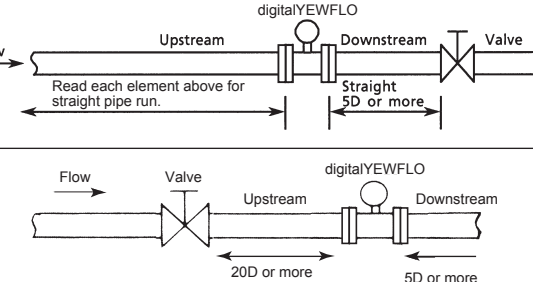
Description	Figure
<p><b>Reducer pipe:</b> Ensure the upstream straight pipe length to be 5D or more, and the downstream straight pipe length to be 5D or more for per reducer pipe.</p>	
<p><b>Expander pipe:</b> Ensure the upstream straight pipe length to be 10D or more, and the downstream straight pipe length to be 5D or more for per expander pipe.</p>	
<p><b>Bent pipe and straight pipe length:</b></p> <ol style="list-style-type: none"> <li>1. Single bent pipe</li> <li>2. Double bent pipe; coplanar</li> <li>3. Double bent pipe; non coplanar</li> </ol>	
<p><b>Valve position and straight pipe length:</b></p> <ul style="list-style-type: none"> <li>■ Install the valve on the downstream side of the flowmeter. The upstream straight pipe length dependent on the element located on the upstream such as reducer/expander, bent and etc., read description as above. Keep 5D or more for downstream straight pipe length.</li> <li>■ In case the valve has to be installed on the upstream of the flowmeter, ensure the upstream straight pipe length to be 20D or more, and the downstream straight pipe length be 5D or more.</li> </ul>	

Table 3.1 (b) Straight pipe length and recommendations (2)

D: Nominal diameter (mm)

Description	Figure
<p><b>Fluid vibration:</b>                      For a gas line which uses a position-type or roots-type blower compressor or a high-pressure liquid line (about 1MPa or more) which uses piston-type or plunger-type pump, fluid vibrations may be produced.                      In these case, install valve on the upstream side of digitalYEWFLO.                      For inevitable fluid vibration, put a vibration damping device such as throttling plate or expansion section in the upstream side of digitalYEWFLO.</p>	
<p><b>Piston-type or plunger pump:</b>                      Install the accumulator on the upstream side of digitalYEWFLO to reduce fluid vibrations.</p>	
<p><b>Valve positon (T-type piping exist):</b>                      When pulsation causes by a T-type piping exist, install the valve on the upstream of the flowmeter.                      Example: As shown in the figure, when the valve V1 is turned off, the fluid flow throught B as to meter A the flow is zero. But due to the pulsating pressure is detected, the meter is zero point become fluctuating. To avoid this, change the valve V1 location to V1'.</p> <p>Note: In case of the Reduced Bore Type, moisture may be remained upstream of the flowmeter. Drain it appropriately.</p>	
<p><b>Pressure and Temperature Taps:</b>                      When the temperature/pressure correction, place a pressure tap in a position on the downstream side 2 to 7D from digitalYEWFLO.                      Then place a temperature tap in a position on the downstream side 1 to 2D from a pressure tap.                      When use a temperature tap only, place it in a position on the downstream side 3 to 9D from digitalYEWFLO.</p>	
<p><b>Mounting Gasket:</b>                      Avoid mounting gaskets which protrude into the pipe line. This may cause inaccurate readings.                      Use the gaskets with bolt holes, even if digitalYEWFLO is the wafer type.                      When using a spiral gasket (without bolt holes), confirm the size with the gasket -manufacturer, as standard items may not be used for certain flange ratings.</p>	

Table 3.1 (c) Straight pipe length and recommendations (3)

Description	Figure
<p><b>Heat-Insulation:</b> When an integral-type flowmeter or a remote type detector is installed and the pipe carrying high-temperature fluids is heat-insulated, do not wrap adiabatic materials around the installation the bracket (DY015 to DY100) or the nozzle (DY150 to DY400) of the converter.</p> <p>Note: Read Section 3.4 "Cryogenic and High Process Temperature Version Insulation" and install it rightly.</p>	
<p><b>Flushing of the pipe line:</b> Flush and clean scale, incrustation and sludge on the inside of pipe for newly installed pipe line and repaired pipe line before the operation. For flushing, the flow should flow through bypass-piping to avoid damaging the flowmeter. If there is no bypass-piping, install short pipe instead of the flowmeter.</p>	

■ Mounting Precautions

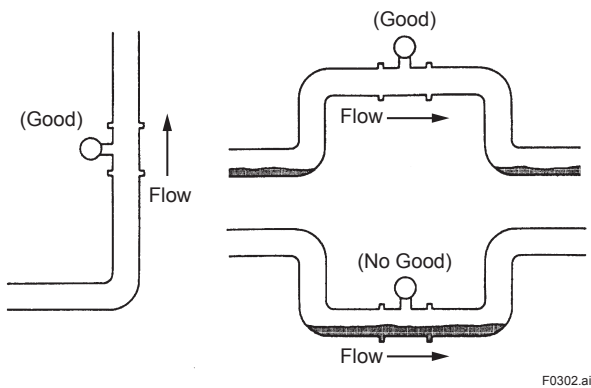


**WARNING**

In case of high process temperature, care should be taken not to burn yourself because the surface of body and case reach a high temperature.

(1) Gas or Steam Measuring Precautions

- Piping to Prevent Standing Liquid  
Mount digitalYEWFLO in a vertical pipeline to avoid liquid traps. When digitalYEWFLO is installed horizontally, raise that part of the pipeline in which the digitalYEWFLO is installed.

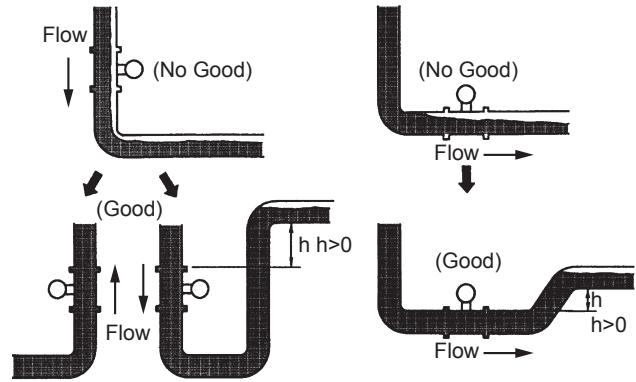


F0302.ai

(2) Liquid Measurement Precautions

To insure accurate measurement, the digitalYEWFLO must always have a full pipe.

- Piping Requirements for Proper Operation  
Allow the flow to flow against gravity. When the flow is moving with gravity, lift the downstream pipe length above the digitalYEWFLO installation level to maintain full pipeline.

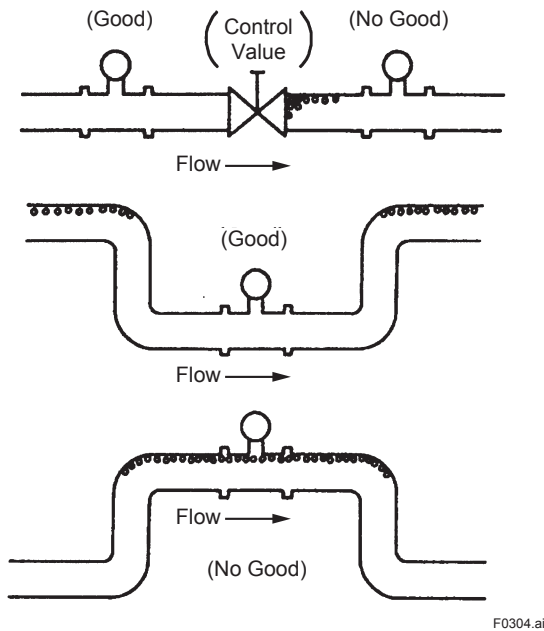


F0303.ai

• Piping for Avoiding Bubbles

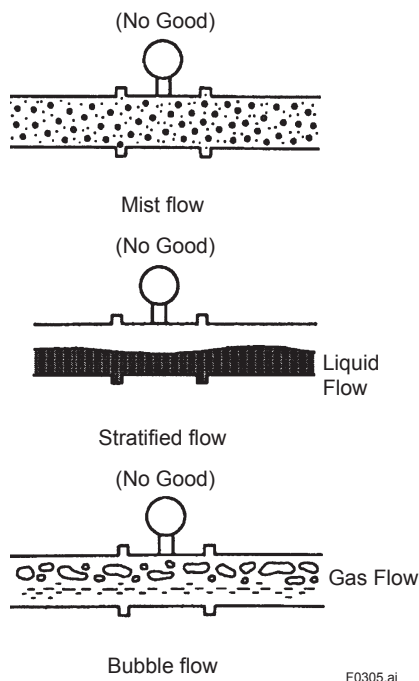
Flows containing both gas and liquid cause problems. Avoid gas bubbles in a liquid flow. Piping should be carried out to avoid bubble generation.

Install the valve on the downstream side of the flowmeter because pressure drop across the control valve may cause gas to come out of the solution.



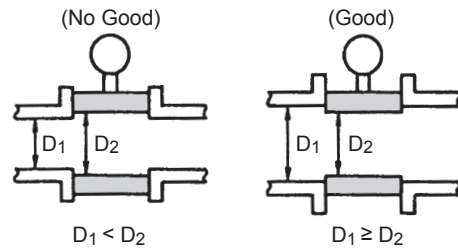
**(3) Multi-Phase Flow**

digitalYEWFlo can measure gas, liquid and steam when there is no change in state. However, accurate measurement of mixed flows (e.g. gas and liquid) is not possible.



**(4) Pipeline Diameter and digitalYEWFlo**

The process pipeline inner diameter should be slightly larger than the vortex flowmeter inner diameter, schedule 40 or lower pipe should be used for 1/2 to 2 inch flowmeters and schedule 80 or lower pipes for 3 to 16 inch flowmeters.



F0306.ai

**(5) Waterproof Construction**

The vortex flowmeter is of IP67, Type 4X, JIS C 0920 watertight protection. However, it cannot be used under water.

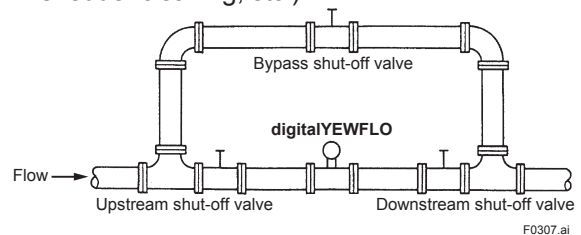
**3.3 Maintenance of Piping**

**(1) Pipe cleaning**

- Flushing of pipe line (Cleaning)  
Flush and clean scale, incrustation and sludge on the inside of pipe wall for newly installed pipe line and repaired pipe line before the operation.
- Fluid Carrying Solids  
Do not measure fluids that carry solids (e.g. sand and pebbles). Make sure users periodically remove solids adhering to the vortex shedder.
- Obstruction of flow fluids may cause to make a chemical reaction and the fluid will be crystallized and hardened, and be deposited on the pipe wall and shedder bar.  
In those cases, clean shedder bar.

**(2) Bypass piping**

Bypass piping is convenient for the maintenance of digitalYEWFlo (vortex shedder cleaning, etc.).



### 3.4 Cryogenic and High Process Temperature Version Insulation

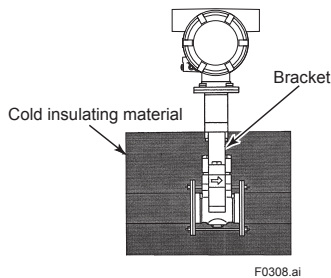
When you are using Cryogenic and High Process Temperature version of digital YEW FLO Vortex Flowmeter (Option code: /HT, /LT), read following contents.

#### ■ Installing Cryogenic Version

For cryogenic applications, use stainless steel mounting bolts and nuts to install the flowmeter. These can be ordered separately from YOKOGAWA. Cover the flowmeter body with heat insulating material so that the flowmeter can be maintained at ultra-low temperatures.

#### ■ Maintenance for Cryogenic Applications

Option code: /LT uses special materials that produce vortex flowmeter for cryogenic applications. When you are replacing a shedder bar, specify Cryogenic Version shedder bar. To avoid condensing in the terminal box, ensure that the wire connecting port is well sealed.

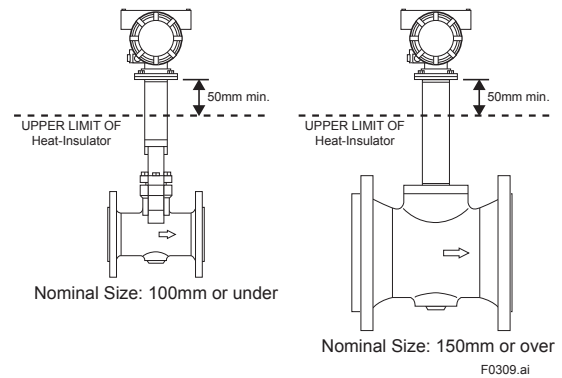


#### ■ Installing High Process Temperature Version

Installation of the flowmeter is the same as the standard type. Cover the flowmeter body with heat insulating material following instruction of "CAUTION".

### CAUTION

Keep the upper limit of heat insulating material to prevent overheating of the terminal box. Seal the Heat-Insulator to avoid hot-air leakage.



#### ■ Maintenance for High Process Temperature Applications

Option code: /HT uses special materials that produce vortex flowmeter for High Process Temperature applications. When you are replacing a shedder bar or a gasket, specify High Process Temperature Version.

### 3.5 Mounting Procedures

### WARNING

The Vortex Flowmeter is a heavy instrument. Please be careful to prevent persons from injuring when it is handled.

Before installing the instrument verify the following.

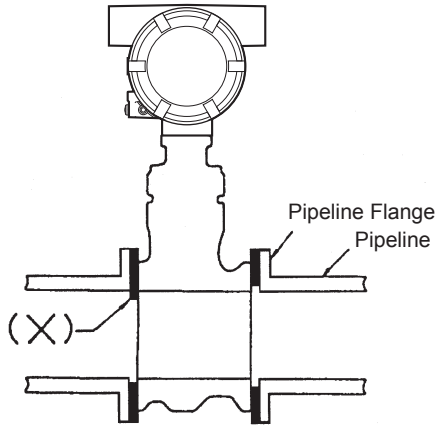
The direction of flow should match to the arrow mark on the instrument body. When changing the orientation of the terminal box, read IM 01F06A00-01EN Chapter 11 "MAINTENANCE."

1. Installation of Vortex flowmeter of the wafer and flange type is shown in Table 3.3.

When installing the wafer type vortex flowmeter, it is important to align the instrument bore with the inner diameter of the adjacent piping.

To establish alignment, use the four collars supplied with the instrument.

- Four collars are supplied for 1/2 inch (15mm) to 1- 1/2inch (40mm), 2 inch of JIS 10K or ANSI class 150, and 3 inch of ANSI class 150. Install the instrument as illustrated in Table 3.3.
- If the adjacent flanges have eight bolt holes, insert the stud bolts in the holes on the instrument shoulder.
- Stainless steel stud bolts and nuts are available on order. When they are to be supplied by the user, read Table 3.2 for stud bolt length. Gaskets must be supplied by the user.

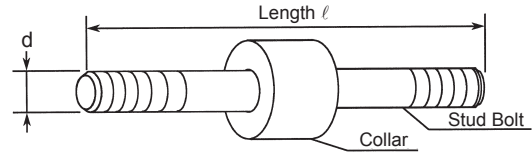


F0310.ai

2. Avoid mounting gaskets which protrude into the pipeline. This may cause inaccurate readings. Use gaskets with bolt holes, even if digitalYEWFL0 is of the wafer type. When using a spiral gasket (without bolt holes), confirm the size with the gasket-manufacturer, as standard items may not be used for certain flange ratings.

Table 3.2 Flange Rating

Size mm (inch)	Flange Rating	Major Diameter of External Thread of Stud Bolt d (mm)	Length ℓ (mm)
15mm (1/2B)	JIS 10K, 20K/DIN 10, 16,25,40	12	160
	JIS 40K	16	160
	ANSI 150, 300, 600	12.7	155
25mm (1B)	JIS 10K, 20K, 40K	16	160
	ANSI 150	12.7	155
	ANSI 300, 600	15.9	160
	DIN 10, 16, 25, 40	12	160
40mm (1-1/2B)	JIS 10K, 20K/DIN 10, 16, 25, 40	16	160
	JIS 40K	20	170
	ANSI 150	12.7	155
	ANSI 300, 600	19.1	170
50mm (2B)	JIS 10K, 20K, 40K/ DIN 10, 16, 25, 40 ANSI 150, 300, 600	16	200
		15.9	200
80mm (3B)	JIS 10K/DIN 10, 16, 25, 40	16	220
	JIS 20K, 40K	20	240
	ANSI 150	15.9	240
	ANSI 300, 600	19.1	240
100mm (4B)	JIS 10K/DIN 10, 16	16	220
	JIS 20K/DIN 25, 40	20	240
	JIS 40K	22	270
	ANSI 150	15.9	240
	ANSI 300	19.1	240
	ANSI 600	22.2	270



F0311.ai

Table 3.3 (a) Installation of Wafer Type Vortex Flowmeter

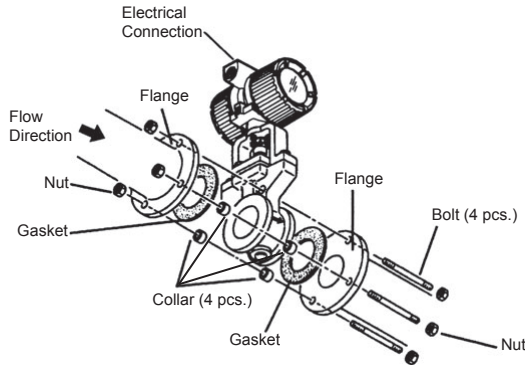
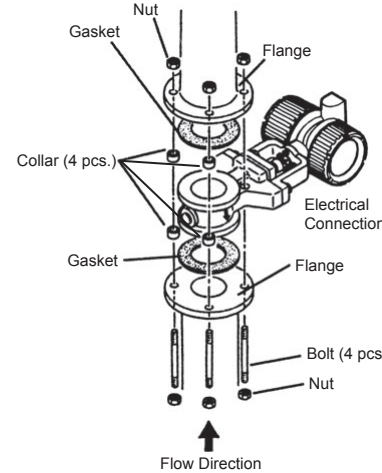
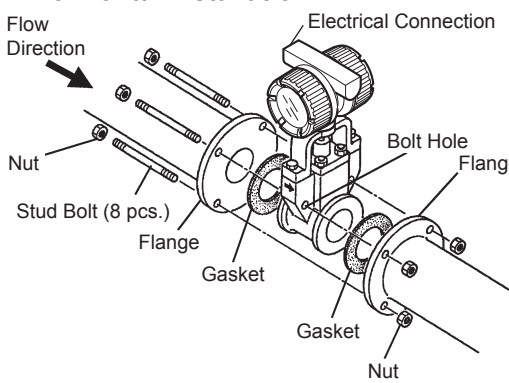
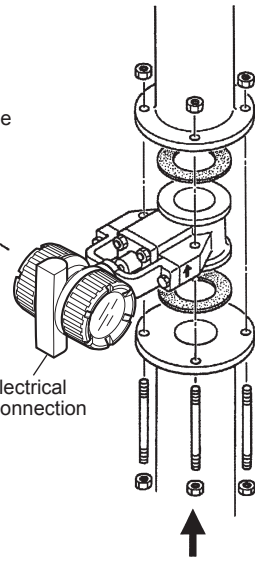
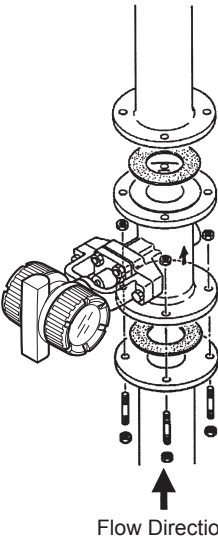
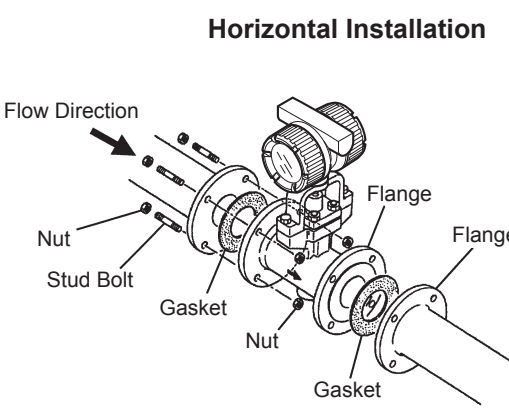
Wafer type	Description								
<p>When Installation Collar are required, the installation vortex flowmeters applied to the following line sizes and flange ratings.</p> <table border="1" data-bbox="181 405 606 584"> <thead> <tr> <th>Size mm (inch)</th> <th>Flange Rating</th> </tr> </thead> <tbody> <tr> <td>15 to 40 (1/2 to 1-1/2)</td> <td>All ratings</td> </tr> <tr> <td>50(2)</td> <td>JIS 10K, ANSI class 150, DIN PN10 to PN40</td> </tr> <tr> <td>80(3)</td> <td>ANSI class 150</td> </tr> </tbody> </table> <p><b>! WARNING</b> The inside diameter of the gasket must be larger than the pipe inner diameter so that it will not disturb the flow in the pipeline.</p> <p><b>! WARNING</b> When installing the Flowmeter vertically in the open air, change the electrical connection port direction to the ground. If the electrical connection port is installed upwards, rain water might leak in.</p> <p><b>! WARNING</b> In case of vertical installation, two collars in the upper part might move after the installation. But it doesn't influence the performance, please use the flowmeter under such condition.</p>	Size mm (inch)	Flange Rating	15 to 40 (1/2 to 1-1/2)	All ratings	50(2)	JIS 10K, ANSI class 150, DIN PN10 to PN40	80(3)	ANSI class 150	<p><b>Horizontal Installation</b></p>  <p><b>Vertical Installation</b></p>  <ol style="list-style-type: none"> <li>(1) Insert two collars on each two bolts of bottom side of the flowmeter.</li> <li>(2) Fit the flowmeter body to the collars. And tighten the four bolts and nuts uniformly.</li> <li>(3) Check for leakage from the flange connections.</li> </ol>
Size mm (inch)	Flange Rating								
15 to 40 (1/2 to 1-1/2)	All ratings								
50(2)	JIS 10K, ANSI class 150, DIN PN10 to PN40								
80(3)	ANSI class 150								
<p>When Installation Collars are not required, the installation vortex flowmeters applied to the following line sizes and flanges.</p> <table border="1" data-bbox="181 1503 606 1682"> <thead> <tr> <th>Size mm (inch)</th> <th>Flange Rating</th> </tr> </thead> <tbody> <tr> <td>50(2)</td> <td>JIS 20K, 40K ANSI class 300, 600</td> </tr> <tr> <td>80(3)</td> <td>JIS 10K, 20K, 40K ANSI class 300, 600</td> </tr> <tr> <td>100(4)</td> <td>JIS 10K, 20, 40K ANSI class 150, 300, 600</td> </tr> </tbody> </table>	Size mm (inch)	Flange Rating	50(2)	JIS 20K, 40K ANSI class 300, 600	80(3)	JIS 10K, 20K, 40K ANSI class 300, 600	100(4)	JIS 10K, 20, 40K ANSI class 150, 300, 600	<p><b>Horizontal Installation</b></p>  <p><b>Vertical Installation</b></p>  <ol style="list-style-type: none"> <li>(1) Insert two stud bolts in the bolt holes on the flowmeter shoulder to align the instrument body with the inner diameter of the adjacent piping.</li> <li>(2) Tighten all bolts uniformly and check that there is no leakage between the instrument and the flanges.</li> </ol>
Size mm (inch)	Flange Rating								
50(2)	JIS 20K, 40K ANSI class 300, 600								
80(3)	JIS 10K, 20K, 40K ANSI class 300, 600								
100(4)	JIS 10K, 20, 40K ANSI class 150, 300, 600								

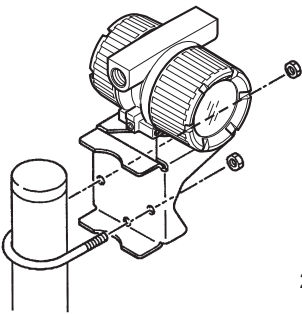
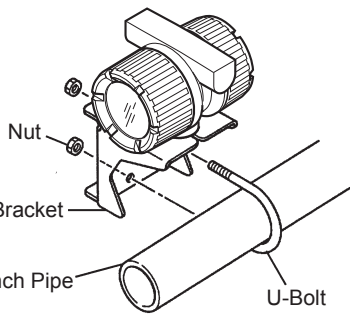


Table 3.3 (b) Installation of Flange Type Vortex Flowmeter

Flange type	Description
<p>Use the stud bolts and nuts supplied with the flowmeter of the user. The gaskets should be supplied by the user.</p> <p><b>CAUTION</b></p> <p>The inside diameter of the gasket must be larger than the pipe inner diameter so that it will not disturb the flow in the pipeline.</p>	<div style="display: flex; justify-content: space-around;"> <div style="text-align: center;">  <p><b>Vertical Installation</b></p> </div> <div style="text-align: center;">  <p><b>Horizontal Installation</b></p> </div> </div>

F0313.ai

Table 3.3 (c) Installation of Remote Type Converter

DYA remote type converter	Description
<p><b>CAUTION</b></p> <p>DYC remote type signal cable is used between the remote type flowmeter and the converter. The maximum signal cable length is 97.5ft (30m).</p>	<p>The converter is mounted on a 2-inch (60.5mm outer dia.) stanchion or horizontal pipe. Do not mount the converter on a vertical pipe. It makes wiring and maintenance difficult. The converter mounting orientation can be changed as illustrated below.</p> <div style="display: flex; justify-content: space-around;"> <div style="text-align: center;">  <p><b>Stanchion Mounting</b></p> </div> <div style="text-align: center;">  <p><b>Horizontal Pipe Mounting</b></p> </div> </div>

F0314.ai

## 4. WIRING



### IMPORTANT

For the descriptions of wiring for the Fieldbus Communication Type, read Chapter 11 “COMMUNICATION (FIELDBUS)”.



### WARNING

The wiring of the vortex flowmeter must be performed by expert engineer or skilled personnel. No operator shall be permitted to perform procedures relating to wiring.



### CAUTION

Once all wiring is complete, check the connections before applying power to the instrument. Improper arrangements or wiring may cause a unit malfunction or damage.

### 4.1 Load Resistance of Output Condition

Be sure to observe the following precautions when wiring:



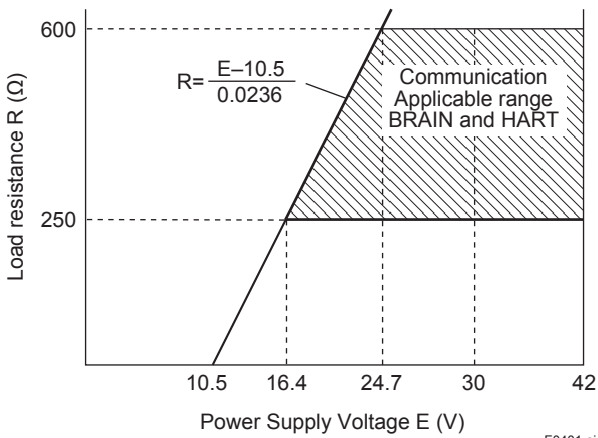
### CAUTION

- When the ambient temperature of the wire exceeds +60°C, use heat-resistant insulated wire with a maximum allowable temperature more than ambient temperature +30°C or above.
- Do not connect cables outdoors in wet weather in order to prevent damage from condensation and to protect the insulation.
- Do not splice the cable between the flowtube terminal and the converter if it is too short. Replace the short cable with a cable that is the appropriate length.
- All the cable ends must be provided with round crimp-on terminals and be securely wired.
- Be sure to turn power off before opening the cover.
- Before turning the power on, tighten the cover securely.
- Explosion protected types must be wired in accordance with specific requirement (and, in certain countries, legal regulations) in order to preserve the effectiveness of their explosion protected features.
- The terminal box cover is locked by the Locking Screw. In case of opening the terminal box cover, use the hexagonal wrench attached.
- Be sure to lock the cover by the Locking Screw using the hexagonal wrench attached after installing the cover.

Table 4.1 shows the connection method of several output conditions.

#### (1) Analog Output (4 to 20 mA DC)

This converter uses the same two wires for both, the signal and power supply. A DC power supply is required in a transmission loop. The total leadwire resistance including the instrument load and power distributor (supplied by the user) must conform to a value in the permissible load resistance range. Read Figure 4.1.



**Figure 4.1 Relationship between Power Supply Voltage and Load Resistance (4 to 20 mA DC Output)**

**(2) Pulse output and Alarm, Status Output**

This version uses three wires between the converter and the power supply. A DC power and load resistance are required, and pulse output is connected to a totalizer or an electric counter. Low level of the pulse output is 0 to 2V. No communication is possible over a transmission line. Communication via the amplifier board is always possible irrespective of the wiring condition.

**(3) Simultaneous Analog-Pulse Output**

When using digital YEWFL0 in the simultaneous analog -pulse output mode, the communicable distance of the transmission line is restricted on the wiring method. Table 4.1 shows the examples of connection for this output mode. Communication via the amplifier board is always possible irrespective of the wiring condition.



**IMPORTANT**

For pulse output and the simultaneous analog-pulse output, use the load resistance. Read Table 4.1.

**4.2 Selection of Wires**

The following should be taken into consideration when selecting cables for use between the converter and distributor.

- (1) Use 600V PVC insulated wire or equivalent standard wire or cable.
- (2) Use shielded wire in areas susceptible to electrical noise (both analog and pulse output versions).
- (3) In areas with high or low ambient temperatures, use wires or cables suitable for such temperatures.
- (4) In atmospheres where oils or solvents, corrosive gases or liquids may be present, use suitable wires or cables.
- (5) Use cable which withstand temperature up to +60°C and more, when ambient temperature is more than +60°C.
- (6) The outer diameter of the screw for grounding terminal and the cable terminal is 4mm.
- (7) Recommend a crimping terminal with an insulating sleeve (for 4mm screw).

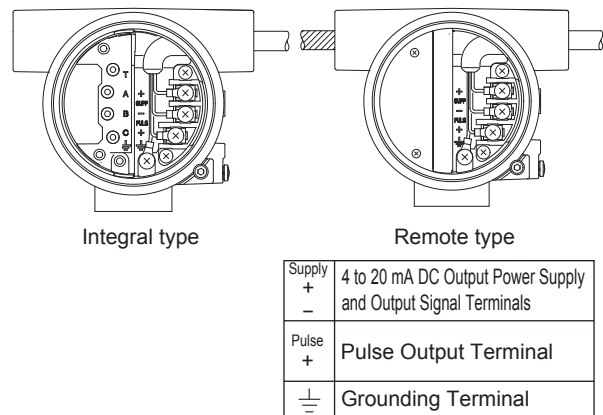


**IMPORTANT**

For the remote type, use DYC remote type signal cable to connect DYA remote type converter and the remote type detector (DY-N).

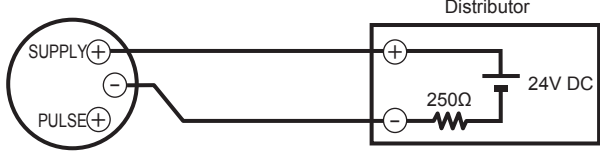
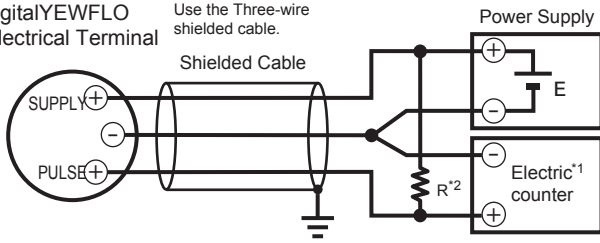
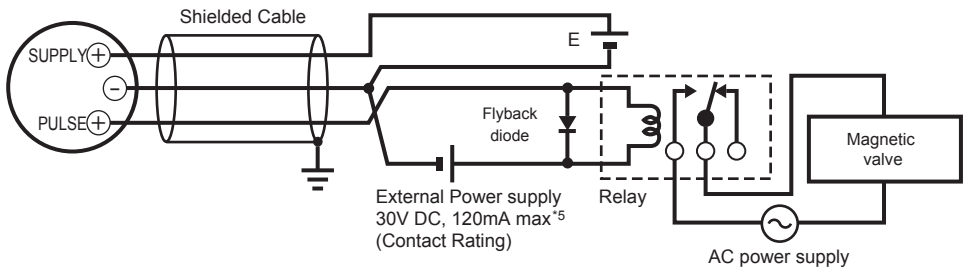
**4.3 Connection**

Table 4.1 shows the connection sample of connection for power supply and load resistance. The terminal position of each connection is shown in Figure 4.2.



**Figure 4.2 Terminal Position**

Table 4.1 (a) The wiring example for the analog and pulse and status, alarm output.

Connection	Description
<p>Analog Output</p> <p>In this case, Communication is possible (up to a distance of 2km when a CEV cable is used.)</p>	<p>digitalYEWFLO Electrical Terminal</p>  <p>Distributor</p> <p>24V DC</p> <p>250Ω</p>
<p>Pulse Output</p> <p>In this case, No communication is possible.</p>	<p>digitalYEWFLO Electrical Terminal</p> <p>Use the Three-wire shielded cable.</p>  <p>Shielded Cable</p> <p>Power Supply *4</p> <p>Electric<sup>1</sup> counter</p> <p>R<sup>2</sup></p>
<p>Status Output Alarm Output</p> <p>In this case, No communication is possible.</p>	<p>digitalYEWFLO Electrical Terminal</p> <p>Use the Three-wire shielded cable.</p>  <p>Shielded Cable</p> <p>External Power supply 30V DC, 120mA max<sup>5</sup> (Contact Rating)</p> <p>Flyback diode</p> <p>Relay</p> <p>AC power supply</p> <p>Magnetic valve</p> <p>E</p>

\*1: To avoid the influence of external noise, use an electric counter which fits to the pulse frequency.

\*2: Resistor is not necessary in case of an electric counter which can receive contact pulse signal directly.

\*4: This flowmeter requires a power supply of greater than or equal to the maximum output current  $E (V) / R (k\Omega) + 25mA$ .

\*5: 80mA max when you select Option code /KS2, /SS2.

Table 4.1 (b) The wiring example for the simultaneous analog and pulse output, the calculation formula of the range of load resistance R for the pulse output.

Connection	Description
<p>Simultaneous Analog -Pulse Output *6</p> <p><b>Example 1</b> In this case, Communication is possible (up to a distance of 2km when a AXFC-0 cable*7 is used).</p> <p><b>Example 2</b> In this case, Communication is possible (up to a distance of 200m when a AXFC-0 cable*7 is used) and R = 1kΩ).</p> <p><b>Example 3</b> In this case, No communication is possible (when shielded cable is not used).</p>	<p>The load resistance should be selected by calculation as shown below.</p> $\frac{E (V)}{120 (mA)^*5} \leq R (k\Omega) \leq \frac{0.1}{C (\mu F) \times f (kHz)} \dots (1)$ <p>Example of CEV cable capacitance ≐ 0.1μF/km</p> <p>Where      E : Supply voltage (V)                                C : Cable capacitance (μF)      f : Frequency of pulse output (kHz)            P : Power ratio of the load resistance (mW)      R : Value of load resistance (kΩ)</p> $P (mW) = \frac{E^2 (V)}{R (k\Omega)} \dots (2)$

\*1: To avoid the influence of external noise, use an electric counter which fits to the pulse frequency.  
 \*2: Resistor is not necessary in case of an electric counter which can receive contact pulse signal directly.  
 \*3: This flowmeter requires a power supply of greater than or equal to the maximum output current E (V) / R (kΩ).  
 \*4: This flowmeter requires a power supply of greater than or equal to the maximum output current E (V) / R (kΩ) + 25mA.  
 \*5: 80mA max when you select Option code /KS2, /SS2.  
 \*6: When using analog and pulse output simultaneously, the HART communication may be influenced by noise comparing analog output only.  
 \*7: AXFC-0 is the dedicated signal cable (without cable end finish) for Yokogawa Magnetic Flowmeter ADMAG AXF series.  
 Read Figure 4.3 for AXF-0.  
 Other shield cable which is equivalent architecture to AXFC-0 can be used for DY. However the material of insulator may decrease the communication distance.

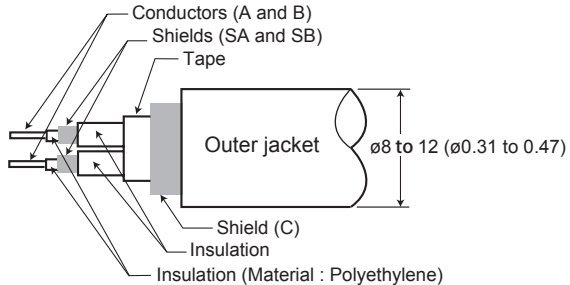


Figure 4.3 AXFC-0 (Read IM 01E20C01-01E)

### 4.4 Connection of DYC Remote Type Signal Cable

DYC remote type signal cable is shown in Figure 4.4 and Figure 4.5, and the terminal is shown in Figure 4.6.

The maximum cable length is 30 m (97.5 feet).

Remove terminal box cover and wiring connection dust-cap before wiring.

For remote type converter has two electrical connections (cable inlets). Use the left connection as viewed from the terminal box for the DYC remote type signal cable and the right connection for the transmission cable.

If a signal cable kit is supplied by YOKOGAWA, both ends of the cable must be finished in accordance with the following instructions. Read Section 4.5 “End Processing Method of DYC Remote Type Signal Cable”.

#### CAUTION

- After completing the signal cable connections, install the shielded cover to signal cable terminal as shown in Figure 4.7.
- To comply with EMC Directive, DYC remote type signal cable shall be in metal conduit piping connection.

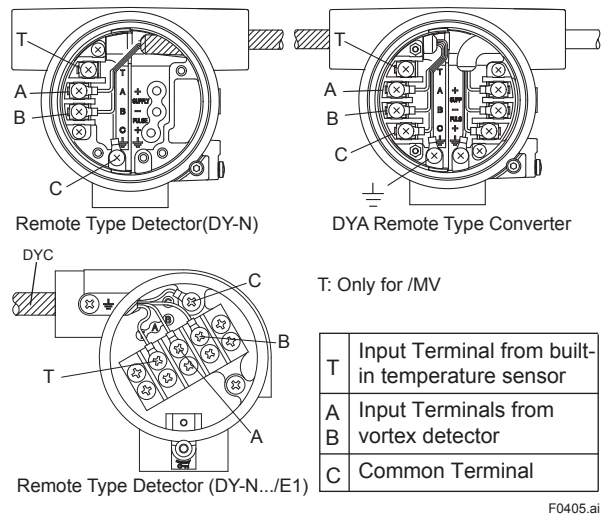


Figure 4.6 Terminal of Detector and Converter

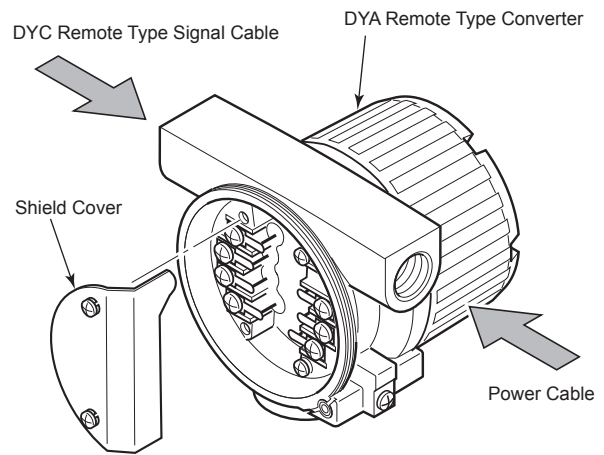


Figure 4.7 Shielded Cover

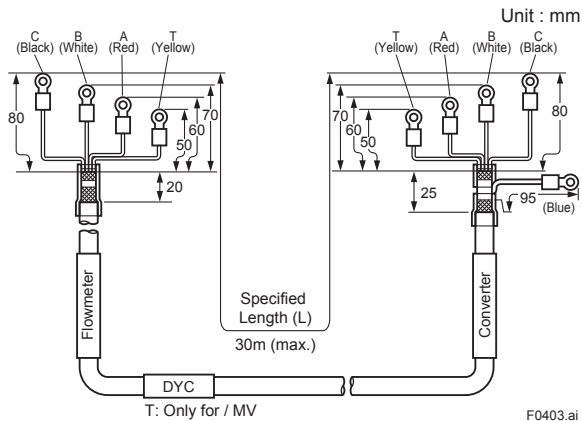


Figure 4.4 DYC Remote Type Signal Cable

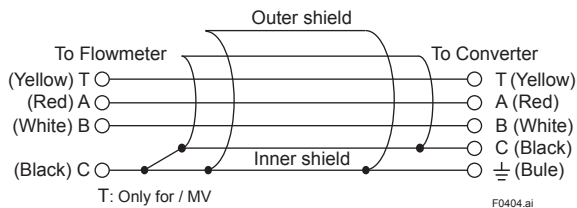


Figure 4.5 Construction of DYC Remote Type Signal Cable

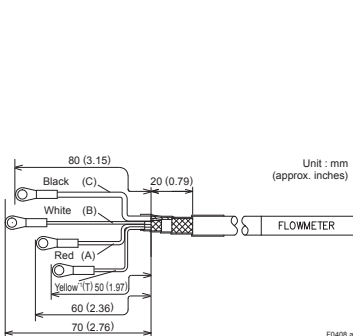
## 4.5 End Processing Method of DYC Remote Type Signal Cable

### 4.5.1 For Remote Type Vortex Flowmeter (DY-N)

	Description	Figure
1	Strip off the outer polyethylene jacket, outer braided shield and inner jacket, and inner braided shield as per the dimensions below.	<p>Unit : mm (approx. inches)</p>
2	Strip off the black conductive layer covering two wires completely, as per the dimensions below. Twist each of the conductor and drain wires so that there are no free strands.	
3	Do not short-circuit the conductive layer and the terminals (A, B, C and T*1).	
4	Strip off about 5 mm (0.2 in.) of insulation for each of wires A, B, and T*1, and twist the strands of each wire. Twist the inner and outer drain wires together.	
5	Slide FEP (fluorinated ethylene propylene) tubing over the twisted inner and outer drain wires C until the tubing cannot be slid any further, and then cut off the tubing leaving 5 mm (0.2 in.) of the stranded drain wires exposed.	
6	Slide heat shrinkable tubing over the cable end so that the tubing covers the braided shield and overlaps both the polyethylene jacket and loose wires A, B, C, and T*1.	
7	Slide a short piece of heat shrinkable tubing over each of wires A, B, C, and T*1. Install a crimp-on terminal lug at the tip of each wire. Crimp and solder each lug.	
8	Slide each short piece of heat shrinkable tubing over the crimp sleeve. Heat all pieces of heat shrinkable tubing with a heat blower or dryer.	
9	<p>Attach an identification label to the end of the cable.</p> <p> <b>NOTE</b></p> <p>Check that the insulation resistance between each wire including the inner shield is 10M or greater at 500V DC. Ensure that both ends of the wires are disconnected (open-circuited) during the check.</p>	

(\*1): Only for /MV

F0407.ai



### NOTE

In case that the cable end finish parts assembly is necessary after delivery, contact your nearest Yokogawa sales office or the sales representative from which you purchased the product.



### CAUTION

Do not touch the "conductive layer" (black area covering the signal cables A and B) to the converter case, terminal, and other leadwires. If it is touched, operation of the converter may be incorrect. When the cable is terminated, remove the conductive layer properly.

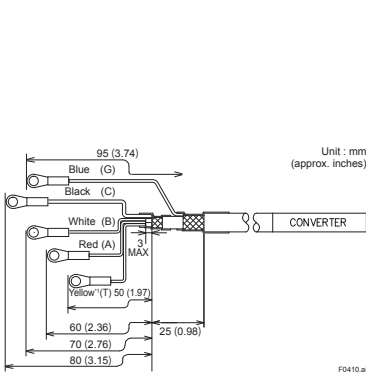
Figure 4.8 End Processing Method of DYC Remote Type Signal Cable for Detector

4.5.2 For DYA Remote Type Converter

1	Description	Figure
	Strip off the outer polyethylene jacket, outer braided shield and inner jacket, and inner braided shield as per the dimensions as shown.	
	Cut off the black conductive layers (covering the two wires) completely, as per the dimensions below. Twist each of the conductor and drain wires so that there are no free strands.	
	Do not short-circuit the conductive layer and the terminals (A, B, C, G, and T*1).	
	Strip off about 5 mm (0.2 in.) of insulation for each of wires A, B, and T*1, and twist the strands of each wire.	
	Slide black FEP (fluorinated ethylene propylene) tubing over the inner shield drain wire C and blue FEP tubing over outer shield drain wire G until the tubing cannot be slid any further, and then cut off the tubing leaving 5 mm (0.2 in.) of the drain wires exposed.	
	Slide heat shrinkable tubing over the cable end so that the tubing covers the braided shield and overlaps both the polyethylene jacket and loose wires A, B, C, G, and T*1.	
	Slide a short piece of heat shrinkable tubing over each of wires A, B, C, G, and T*1. Install a crimp-on terminal lug at the tip of each wire. Crimp and solder each lug.	
	Slide each short piece of heat shrinkable tubing over the crimp sleeve. Heat all pieces of heat shrinkable tubing with a heat blower or dryer.	
	<p>Attach an identification label to the end of the cable.</p> <p><b>NOTE</b></p> <p>Check that the insulation resistance between each wire including the inner shield is 10M or greater at 500V DC. Ensure that both ends of the wires are disconnected (open-circuited) during the check.</p>	

(\*1): Only for /MV

F0409.ai



**NOTE**

In case that the cable end finish parts assembly is necessary after delivery, contact your nearest Yokogawa sales office or the sales representative from which you purchased the product.

**CAUTION**

Do not touch the "conductive layer" (black area covering the signal cables A and B) to the converter case, terminal, and other leadwires. If it is touched, operation of the converter may be incorrect. When the cable is terminated, remove the conductive layer properly.

Figure 4.9 End Processing Method of DYC Remote Type Signal Cable for Converter



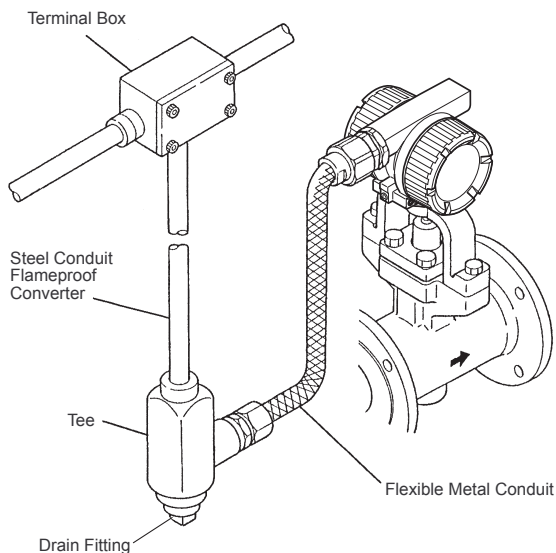
## 4.6 Wiring Procedures and Precautions



### NOTE

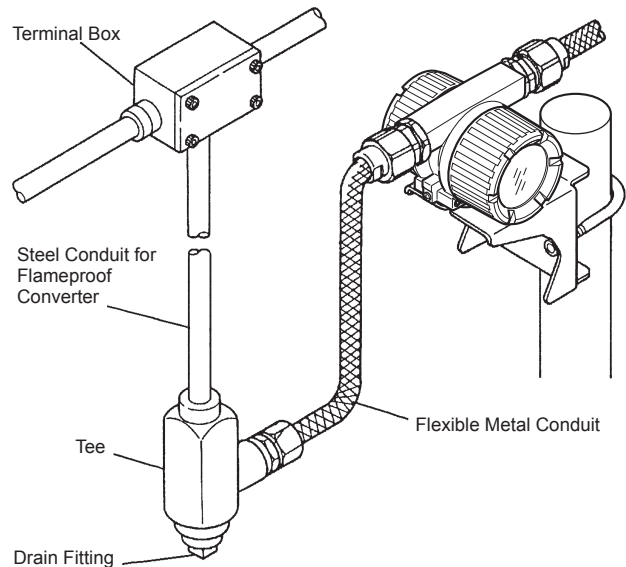
Once all wiring is complete, check the connections before applying power to the instrument. Improper arrangements or wiring may cause a unit malfunction or damage.

- (1) Lay wiring as far as possible from electrical noise sources such as large capacity transformers, motors, and power supplies.
- (2) Remove the terminal cover and dustproof plug of an electrical connection before wiring. When you open the cover of explosion protected type (\*), turn the Locking Screw to the right, and unlock. When you close a cover after wiring, be sure to turn the Locking Screw to the left and lock.
- (\*) Flameproof (TIIS, ATEX, IECEx)
- (3) It recommends using a flexible metal conduit and a duct for waterproofing or external protection of an electric wire. Read Figure 4.10 and Figure 4.11.
- (4) The flameproof packing adapter (option code: /G11 or /G12) should be used for the external wiring of TIIS Flameproof. Read "INSTALLATION AND OPERATING PRECAUTIONS FOR TIIS FLAMEPROOF EQUIPMENT."



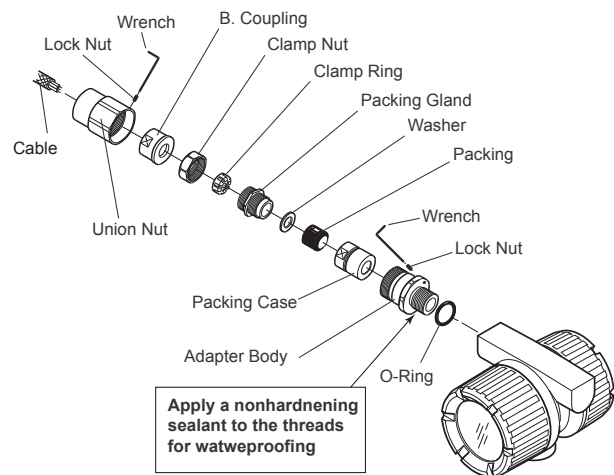
F0411.ai

Figure 4.10 Example of Wiring (Integral Type and Remote Type Detector (DY-N))



F0412.ai

Figure 4.11 Example of Wiring (DYA Remote Type Converter)



F0413.ai

Figure 4.12 Cable Wiring

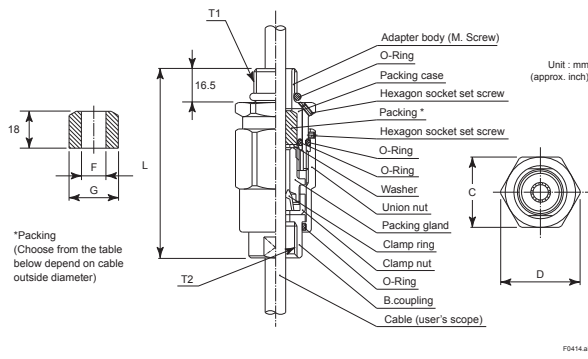


### NOTE

Be sure to use the flameproof packing adapter (option code: /G11 or /G12) for TIIS flameproof type at the time of cable wiring work. Read Figure 4.13.

Table 4.2 Flameproof packing adaptor

Option Code	Diameter for screw	Cable outer diameter mm (inch)	Identification mark	Parts NO.
G11	G11	ø8.0 to ø10.0 (ø0.31 to ø0.39)	16 8-10	G9601AM
G12	G12	ø10.0 to ø12.0 (ø0.39 to ø0.47)	16 10-12	



Size					Cable outer diameter	Packing dimensions		Identification mark	Weight kg (lb)
T1	T2	C	D	L		F	G		
G 1/2	G 1/2	35 (1.38)	39 (1.54)	94.5 (3.72)	ø8.0 to ø10.0 (ø0.31 to ø0.39)	ø10.0 (ø0.39)	ø20.0 (ø0.79)	16 8-10	0.26 (0.57)
					ø10.0 to ø12.0 (ø0.39 to ø0.47)	ø12.0 (ø0.47)			

**Figure 4.13 Flameproof Packing Adapter (option code: /G11, /G12)**

- (5) Perform attachment of flameproof socket packing adaptor in the following ways. Read Figure 4.12.
  - (a) Loosen the locking screw and remove the terminal box cover.
  - (b) Measure the cable outer diameter in two directions to within 0.1 mm.
  - (c) Calculate the average of the two diameters, and use packing with an internal diameter nearest to this value. Read Table 4.2.
  - (d) Screw the flameproof packing adaptor into the terminal box until the O-Ring touches the wiring port (at least 6 full turns), and firmly tighten the lock nut.
  - (e) Insert the cable through the union nut, the B. coupling, the clamp nut, the clamp ring, the packing gland, the washer, the packing, and the packing case, in that order.
  - (f) Insert the end of the cable into the terminal box.
  - (g) Tighten the union cover to grip the cable. When tightening the union cover, tighten approximately one turn past the point where the cable will no longer move up and down. Proper tightening is important. If it is too tight, a circuit break in the cable may occur; if not tight enough, the flameproof effectiveness will be compromised.
  - (h) Fasten the cable by tightening the clamp nut.
  - (i) Tighten the lock nut on the union nut.
  - (j) Connect the cable wires to each terminal.

- (6) Be sure to observe the following precautions when wiring.
  - (a) Do not connect cables outdoors in wet weather in order to prevent damage from condensation and to protect the insulation.
  - (b) Do not splice the cable between the flowtube terminal and the converter if it is too short. Replace the short cable with a cable that is the appropriate length.
  - (c) The signal cables must be routed in separate steel conduit tubes 16 (JIS C 8305) or flexible conduit tubes 15 (JIS C 8309).
  - (d) Always route the power and output signal cables in separate steel conduit tubes, except when the power supply voltage is 24 V and four-core cables are used for wiring. Keep conduits or flexible tubes watertight using sealing tape.

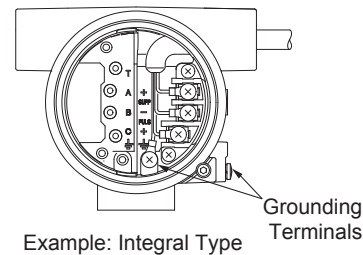
### 4.7 Grounding



#### IMPORTANT

When a lightning protector (option code: /A) is selected, use a grounding resistance of 10Ω or less.

- (1) The grounding terminals  $\perp$  are located on the inside and outside of the terminal area. Either terminal may be used. Read Figure 4.14.
- (2) For pulse output version, ground the flowmeter. Also ground the shielded cable between the converter and the pulse receiver.
- (3) Grounding should satisfy Class D requirements (ground resistance 100Ω or less).
- (4) Use 600V PVC insulated wire for grounding.



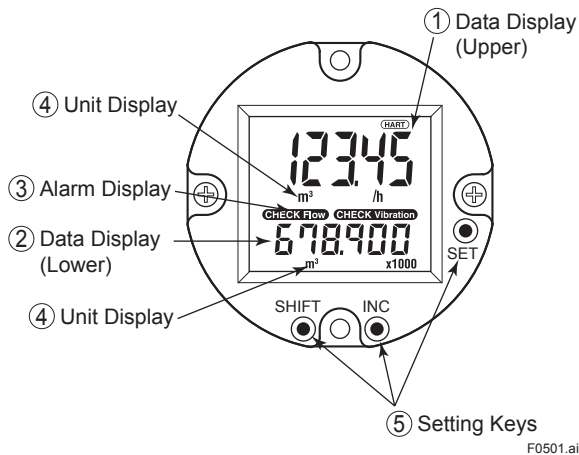
**Figure 4.14 Grounding Terminal**

# 5. BASIC OPERATING PROCEDURES (DISPLAY)

Data setting can be performed with the three keys on the front panel (SET,SHIFT and INC) or using a handheld BRAIN TERMINAL (BT200) and HART communicator.

## 5.1 Display Configuration

Figure 5.1 shows the configuration of the digital YEW FLO display panel (if equipped).



**Figure 5.1 Display Configuration**

- ① Data Display(Upper) : flowrate data, setting data, total data  
temperature data (/MV)
- ② Data Display(Lower) : total data, alarm data  
temperature data (/MV)
- ③ Alarm Display : alarm of a flow error and a  
vibration error
- ④ Unit Display : flowrate unit
- ⑤ Setting Keys : These keys are used to  
change flow rate data  
displays and type of  
setting data

Read IM01F06A00-01EN Section 5.2 for “Display Contents”, Section 5.3 for “Display Mode”, Section 5.4 for “Setting Mode”.

# 6. PARAMETERS

## 6.1 digitalYEWFO Parameters

The parameters are set before factory shipment. Set the required parameter of changing fluid, contact out and indication of display.

## 6.2 Parameter Configuration

- Item A: Indication
- Item B: Easy Setting
- Item C: Basic Setup
- Item D: Additional Setup
- Item E: Detector Setup
- Item F: Thermometer (Only for Multi-Variable Type)
- Item H: Adjust
- Item J: Test
- Item K: Maintenance
- Item M: Memo



### IMPORTANT

For the remote type, be sure to set the cable length (F52) for DYA remote type converter, because of effect of the cable length.

Read IM01F06A00-01EN Section 6.3 for "Parameter List", Section 6.4 for "Parameter Description".

### 6.3 Self-Diagnostic (Error Code List)

When an ERROR is displayed by SELF CHECK in item A60, B60, C60, D60, E60, H60, J60, K60 or M60, press function key F2 [DIAG] and the error contents are displayed.

Indication	Diagnostic Message	Error Name	Problem Cause	Current Output		% Output		Pulse Output	Engineering Unit Output	Totalizing Output	Engineering Temp Output	Pulse / Status Output		How to recover	
				Select flow rate	Select temperature	Select flow rate	Select temperature					Pulse <sup>(*)</sup>	Status <sup>(*)</sup>		Alarm <sup>(*)</sup>
Err-01	FLOW OVER OUTPUT	Over range output signal	Output signal is 110% or more <sup>(*)</sup>	Fixed at 110% <sup>(*)</sup>	Normal Operation	Fixed at 110% <sup>(*)</sup>	Normal Operation	Normal Operation	Normal Operation	Normal Operation	Normal Operation	Normal Operation	OFF(H)	Change parameters or over ranged flow input	
Err-02	SPAN SET ERROR	Span Setting Error	Span setting parameter is more than 1.5 times of max flow velocity	Normal Operation	Normal Operation	Normal Operation	Normal Operation	Normal Operation	Normal Operation	Normal Operation	Normal Operation	Normal Operation	OFF(H)	Change parameters span factor is outside the acceptable limits	
Err-06	PULSE OUT ERROR	Pulse output error	Pulse output frequency is more than 10kHz	Normal Operation	Normal Operation	Normal Operation	Normal Operation	Fixed at 10kHz	Normal Operation	Normal Operation	Normal Operation	Normal Operation	OFF(H)	Change parameters (ItemC.ItemE)	
Err-07	PULSE SET ERROR	Pulse setting error	Pulse output frequency setting is more than 10kHz	Normal Operation	Normal Operation	Normal Operation	Normal Operation	Normal Operation	Normal Operation	Normal Operation	Normal Operation	Normal Operation	OFF(H)	Change parameters (ItemC.ItemE)	
CHECK Vibration	Transient noise	Error of Vibration	Transitional disturbance	Hold	Normal Operation	Hold	Normal Operation	Normal Operation	Hold	Normal Operation	Normal Operation	Hold	OFF(H)	CHECK the vibration	
CHECK Vibration	High vibration	Error of Vibration	High vibration	Based on K45	Normal Operation	Based on K45	Normal Operation	Based on K45	Based on K45	Stop the total	Normal Operation	Normal Operation	OFF(H)	CHECK the vibration	
CHECK Flow	Fluctuating	Error of Flow	Fluctuating	Normal Operation	Normal Operation	Normal Operation	Normal Operation	Normal Operation	Normal Operation	Normal Operation	Normal Operation	Normal Operation	OFF(H)	CHECK the dlogging	
CHECK Flow	Clogging	Error of Flow	Clogging	Normal Operation	Normal Operation	Normal Operation	Normal Operation	Normal Operation	Normal Operation	Normal Operation	Normal Operation	Normal Operation	OFF(H)	CHECK the dlogging	
Err-10 <sup>(*)</sup>	TEMP OVER OUTPUT	Over range Temp output signal	Temp output signal is 110% or more, and 0% below.	Normal Operation	Fixed at 110% in case of over 110%, and fixed at 0% when in case of less than 0% <sup>(*)</sup>	Normal Operation	Fixed at 110% in case of over 110%, and fixed at 0% when in case of less than 0% <sup>(*)</sup>	Normal Operation	Normal Operation	Normal Operation	Normal Operation	Normal Operation	Normal Operation	OFF(H)	CHECK the temperature or temperature span
Err-11 <sup>(*)</sup>	OVER TEMP	Error of temperature	Temp value is -50°C below or 300°C over.	Remain in operation at Temp=50°C or Temp=300°C	Remain in operation at Temp=50°C or Temp=300°C	Remain in operation at Temp=50°C or Temp=300°C	Remain in operation at Temp=50°C or Temp=300°C	Remain in operation at Temp=50°C or Temp=300°C	Remain in operation at Temp=50°C or Temp=300°C	Remain in operation at Temp=50°C or Temp=300°C	Remain in operation at Temp=50°C or Temp=300°C	Remain in operation at Temp=50°C or Temp=300°C	OFF(H)	CHECK the temperature	
Err-12 <sup>(*)</sup>	TEMP SENSOR FAULT	Error of thermometer	Disconnection or short of thermometer sensor	Remain in operation at Manual setting condition	Based on F58	Remain in operation at Manual setting condition	Based on F58	Remain in operation at Manual setting condition	Remain in operation at Manual setting condition	Remain in operation at Manual setting condition	Based on F58	Remain in operation at Manual setting condition	OFF(H)	Change thermometer sensor.	
Err-13 <sup>(*)</sup>	TEMP CONV. FAULT	Error of temperature converter	Temperature converter is failed	Remain in operation at Manual setting condition	Based on F58	Remain in operation at Manual setting condition	Based on F58	Remain in operation at Manual setting condition	Remain in operation at Manual setting condition	Remain in operation at Manual setting condition	Based on F58	Remain in operation at Manual setting condition	OFF(H)	Change converter case build in temperature sensor.	
Err-20	PRE-AMP ERROR	PRE-AMP is failed		Normal Operation	Normal Operation	Normal Operation	Normal Operation	Normal Operation	Normal Operation	Normal Operation	Remain in Manual Setting Temperature Value	Normal Operation	OFF(H)	Replace the AMP unit	
Err-30	EEPROM ERROR	EEPROM is not functioning correctly		Over 110% or -2.5% below	Over 110% or -2.5% below	Over 110% or -2.5% below	Over 110% or -2.5% below	Over 110% or -2.5% below	Over 110% or -2.5% below	Over 110% or -2.5% below	Over 110% or -2.5% below	Over 110% or -2.5% below	OFF(H)	Replace the AMP unit	
Err-40	FLOW SEBSOR FAULT	Error of Flow sensor	Flow sensor is fault.	Normal Operation	Normal Operation	Normal Operation	Normal Operation	Normal Operation	Normal Operation	Normal Operation	Normal Operation	Normal Operation	OFF(H)	Change Flow sensor	
	CPU FAULT	CPU is failed	All operations are Dead. Display and self diagnostic function is also dead.g	Over 110% or -2.5% below	Over 110% or -2.5% below	Over 110% or -2.5% below	Over 110% or -2.5% below	Over 110% or -2.5% below	Over 110% or -2.5% below	Over 110% or -2.5% below	Over 110% or -2.5% below	Over 110% or -2.5% below	Halt	Replace the AMP unit	

Note: Normal Operation : Operation continues without relation to error occurrence.  
 Remain in Operation : Calculation continues with relation to error occurrence.  
 (\*1): "110%" is based on "D30 : OUT LIMIT(H)".  
 (\*2): Pulse output : These conditions should be done in case of which B20 is "SCALED PULSE", "UNSCALED PULSE", "FREQUENCY".  
 Status output : These conditions should be done in case of which B20 is "FLOW SW (LOW : ON)", "FLOW SW (LOW : OFF)".  
 Alarm output : These conditions should be done in case of which B20 is "Alarm".  
 (\*3): Only for /MV

# 7. COMMUNICATION (BRAIN / HART)

This chapter describes the operation procedures using a BRAIN TERMINAL (BT200). For details on the functions of the digitalYEWFLO, read Chapter 6 “PARAMETERS.” And also, read the “Model BT200 BRAIN TERMINAL” Instruction Manual (IM 01C00A11-01E) for more detailed Information.

## 7.1 Connection Method for the BT200

### (1) Connecting the BT200 to a 4 to 20mA DC Transfer Line

The communication signal of the digitalYEWFLO is superimposed onto the 4 to 20mA DC analog signal to be transferred.

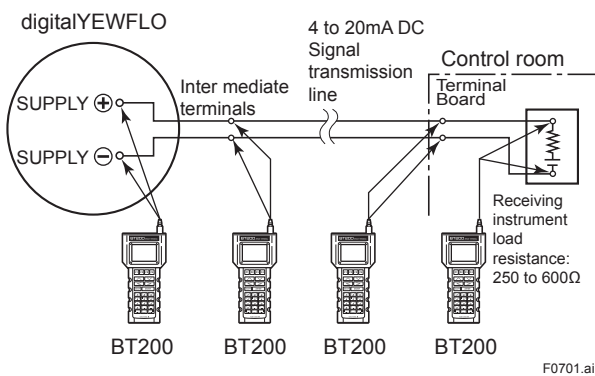


Figure 7.1 Communicating for a 4 to 20mA DC Signal Line



### IMPORTANT

Communication signal is superimposed on analog output signal. It is recommended to set a low-pass filter (approximately 0.1s) to the receiver in order to reduce the output effect from communication signal. Before online-communication, confirm that communication signal does not give effect on the upper system.



### IMPORTANT

The communicable distance of the transmission line is restricted depending on the wiring method. Read Chapter 4 “WIRING.”



### IMPORTANT

After setting a parameter, keep the power on for at least 30 seconds.

If the power of flowmeter is turned off, a parameter setting is released.

### (2) Connection of BT200 to Flow Converter

Removing a cover and indicator, the terminals for BRAIN communication are provided on the circuit board.

Connect BT200 to the terminal of HHT-COM on the circuit board.

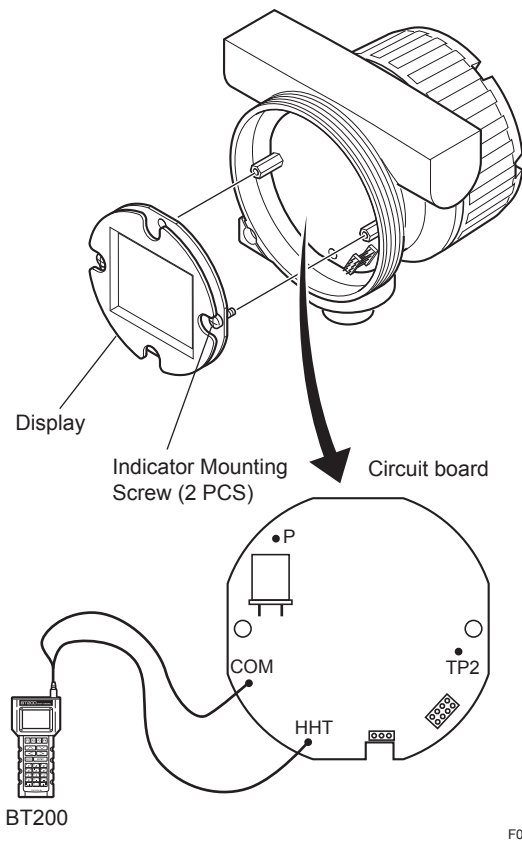
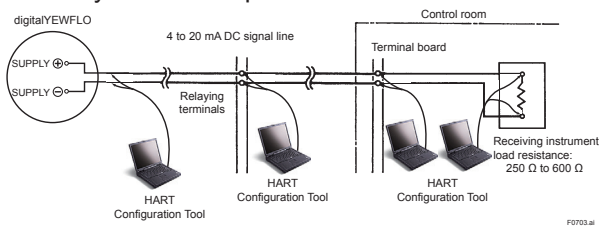


Figure 7.2 Connection of BT200 to Flow Converter

## 7.2 Connection Method for the HART Configuration Tool

The HART Configuration Tool can interface with the digitalYEWFLOW from the control room, the digitalYEWFLOW site, or any other wiring termination point in the loop, provided there is a minimum load resistance of  $250\ \Omega$  between the connection and the receiving instrument. To communicate, it must be connected in parallel with the digitalYEWFLOW, and the connections must be non-polarized. Figure 7.3 illustrates the wiring connections for a direct interface at the digitalYEWFLOW site. The HART Configuration Tool can be used for remote access from any terminal strip as well.



**Figure 7.3 Connecting the HART Communicator**

Read IM 01F06A00-01EN Section 7.2 for “BT200 Screen and Displaying Flow Rate” and Section 7.3 “Setting Parameters using BT200”.  
 Read IM 01F06A00-01EN Chapter 8 for “OPERATION VIA HART CONFIGURATION TOOL (HART 5)”, Chapter 9 for “OPERATION VIA HART CONFIGURATION TOOL (HART 7)”

Note: HART is a registered trademark of the HART Communication Foundation (HCF).

# 8. OPERATION

After you have installed the flowmeter into the process piping, wired the input/output terminals, set up the required parameters, the vortex flowmeter should output an accurate flow signal from its terminals as soon as the measured liquid begins to flow.

This section describes procedure of test method and adjustment method for the pre-operation.



## NOTE

The initial parameter setting has already been done at the factory according to the sizing data when ordering. Therefore it is not necessary to set parameters except measurement condition changes or some additions happen.

## 8.1 Adjustment

### 8.1.1 Zero Adjustment

No zero adjustment is necessary since the zero point does not shift.

Because of the effect of electrical noise and vibration noise, digitalYEWFLO may provide an output even when the flowrate is zero. In that case, properly eliminate the source of the noise.

Read Section 8.2 “Adjustment for Manual Mode.”

### 8.1.2 Span Adjustment

In normal application, you need not confirm the span.

If you need to ensure the output of 4 to 20mA DC, read Subsection 8.1.3 “Loop Test.”

### 8.1.3 Loop Test

To ensure output of 4 to 20mA DC or pulse, their loop tests can be done using parameter “J10 (Analog out)” or “J20 (Pulse test)”.

If you are verifying the analog output, follow the procedure on the verification procedure.

<Check Procedure>

1. Connect the instruments referring to Figure 8.1, and warm up for three minutes more.
2. Set span frequency in Parameter J10:OUT ANALOG.

3. In case the load resistance is 250Ω, digital multimeter indicates 5V. Otherwise if it is known load resistance value, it indicates  $R (\Omega) \times 0.02 (A)$ .
4. Check output value is in the rated value ( $\pm 0.016 \text{ mA}$ ) after set 50% in Parameter J10.
5. Check output value is in the rated value ( $\pm 0.016 \text{ mA}$ ) after set 0% in Parameter J10.

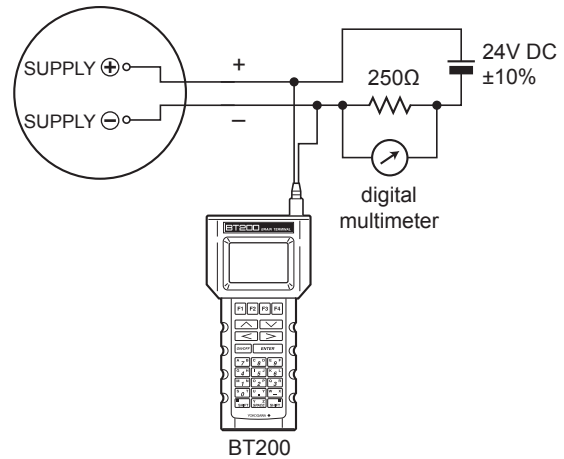


Figure 8.1 Connection of Maintenance Instruments



## IMPORTANT

- When using any test-purpose measuring instruments, do not ground them.
- All of your parameter settings will be cancelled if you turn digitalYEWFLO off less than 30 seconds after the parameter setup. Keep digitalYEWFLO turned on at least 30 seconds after setting up the parameters.



## NOTE

When configure the parameters using the HART Configuration Tool, read IM 01F06A00-01EN Section 8.11 “Menu Tree (HART 5)” or IM 01F06A00-01EN Section 9.11 “Menu Tree (HART 7).”



**8.1.4 Totalizer Start and Totalizer Reset**

When using the Totalizer Function, the start setup should be done.

- (1) Start operation using BT200  
Enter to B40(TOTAL START), and move the video bar to “EXECUTE”. Push “ENTER” key at 2 times.
- (2) Start operation using indicator  
Enter to “Setting mode”, move to B40 of parameter number, and enter to “01” of data number.  
Read Section IM 01F06A00-01EN 5.4 “Setting Mode.”

Totalized value can be reset using the indicator or BT200.

- (1) Reset operation using BT200  
Enter to B42 (TOTAL RESET), and move the video bar to “EXECUTE”. Push “ENTER” key at 2 times.
- (2) Reset operation using indicator  
Enter to “Setting mode”, move to B47 of parameter number, and enter to “01” of data Number.  
Read IM 01F06A00-01EN Section 5.4 “Setting Mode.”

**8.1.5 Setting of Pulse Output (Scaling)**

Pulse output are constructed by two units, that are “Scaled pulse and Unscaled Pulse”.

**(1) Scaled Pulse**

When SCALED PULSE is selected in B20, set flowrate per one pulse output. Rate unit is linking to the flow unit.

**(2) Unscaled Pulse**

When UNSCALED PULSE is selected in B20, it outputs the pulse calculated by following formula. The formula for output pulse number is as follows. Output pulse number per one second = vortex number per one second / PULSE RATE set number.

Read IM 01F06A00-01EN Section 11.6 “Flow Calculation.”


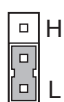
**● Pulse Rate setting**

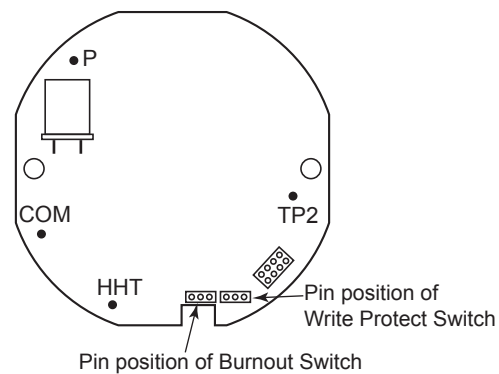
Pulse rate setting is settable by “B21:PULSE RATE”.

**8.1.6 Setting of Burnout Switch**

digitalYEWFLO is equipped with a CPU error burnout function used to set the output direction upon CPU error, and a sensor burnout function that sets the direction of the output in the event of burnout of the temperature sensor. When factory-shipment under normal conditions, the output of both CPU error burnout and sensor burnout are set to HIGH, but if option code /C1 is specified, the CPU error burnout is set to LOW(-2.5% below) output, and sensor burnout is set to LOW(-2.5% below) output, respectively. The setting of the direction of output from burnout can be changed. To change the direction of output arising from burnout, switch the setting pin on the CPU assembly (Read Table 8.1).

**Table 8.1 Output Setting Pin for Burnout**

Pin position	CPU error burnout direction	CPU error burnout output	Remark
 H	HIGH	110% or more (21.6mA DC)	Set to HIGH before shipment.
 L	LOW	-2.5% or less (3.6mA DC)	Set to LOW for option code /C1.



F0802.ai

**Figure 8.2 Pin position of Burnout and Write Protect Switch**

### 8.1.7 Setting of Write Protect Switch

By setting the write protect function to “Protect”, it is possible to prevent the overwriting of parameters. Write protection can be carried out using either the hardware switch on the CPU board (i.e., Switch 2) or software parameter settings. If either of these items is set to “Protect”, the overwriting of parameters will be prohibited.



#### NOTE

If the hardware switch is set to “Protect”, it will not be possible to overwrite parameters; furthermore, this condition will be maintained until the switch is set to “Enable”.

For more details regarding usage of the write protect function and the software’s parameter switches, read IM 01F06A00-01EN Section 8.9 “Software Write Protect” or IM 01F06A00-01EN Section 9.9 “Software Write Protect.”

**Table 8.2 Setting pin for Write Protect**

Pin position	CPU error burnout direction
	Enable
	Protect

### 8.1.8 Power Failure

When a power failure occurs, the totalized value will be protected by EEPROM (Electrically Erasable Programmable ROM). But during a power failure, the vortex flowmeter stops and also the totalizing will stop.

After a power is recovered, the vortex flowmeter and the totalizing start to work automatically. EEPROM doesn’t need a battery for backup.

## 8.2 Adjustment for Manual Mode

digitalYEWFL0 does not need the initial adjustment because digitalYEWFL0 is always adjusted by itself automatically.

These adjustments should be done in case that indicator reads over zero at zero flow.

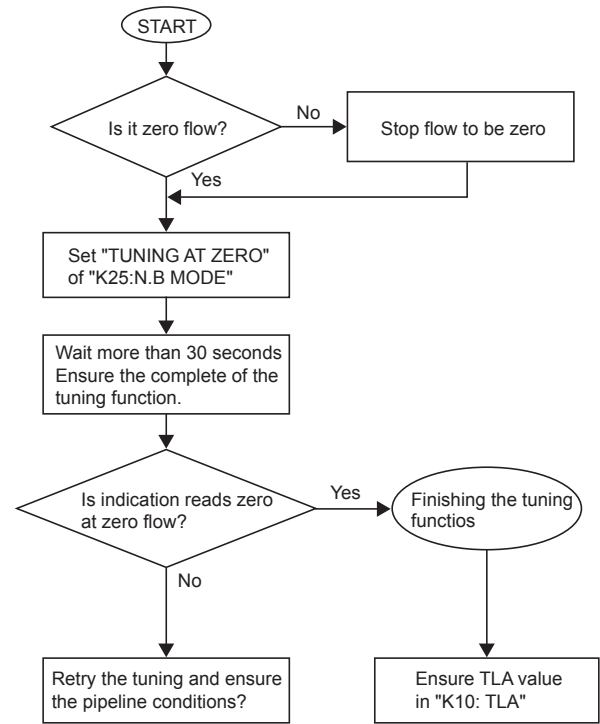
### 8.2.1 Low Cut Adjustment

Adjust to noise elimination or zero flow in the low flowrate (or low frequency) range.

The settable range for low cut flowrate is to half of minimum flowrate.

### 8.2.2 Zero Tuning

This adjustment should be done according to a flow figure shown below.



F0803.ai

**Figure 8.3 Tuning Flow**

If this adjustment is executed, the following value is changed.

K25:N.B MODE = MANUAL

K26:NOISE RATIO=Constant value

Minimum flowrate is increased when TLA value is changed form initial value.

### 1. Tuning method

(1) Ensure the condition of flowrate  
The necessary condition for tuning function is zero flow.

(2) Executing the tuning function.  
Set "TUNING AT ZERO" of "K25:N.B MODE".  
Wait more 30 second.

(3) Finishing the tuning functions

#### Using the BT200

- (a) Press "DATA" key of BT200 function key.
- (b) Ensure the indication of "MANUAL" which is "K25:N.B MODE" ("NOW TUNING" is indicated during tuning operation.)

#### Using the indicator

- (a) Press "SHIFT" and "SET" key simultaneously.
- (b) Press "SET" key and ensure "01" of Lower indication. ("02" is indicated during tuning operation. Execute (a), (b) once again.)

### 2. TLA value

TLA values is possible to change after executing "TUNING". In this case, minimum flowrate is increased.

Minimum flowrate for TLA value is given by below equation.

$$\text{Minimum Flowrate after changing TLA Value} = \text{Specified Minimum Flowrate} \times \sqrt{\frac{\text{TLA Value after Tuning}}{\text{TLA initial value or default value}}}$$

F0804.ai

Ensure minimum flowrate for changing TLA value.

### 3. Output

After tuning, ensure that the indication reads is zero where no fluid is flowing.

If the indication reads over zero is done continuously, retry the tuning and ensure the below condition.

#### Does high vibrations occur in pipeline?

In this case, read Section 3.1 "Installation Precautions", and keep the pipeline properly.

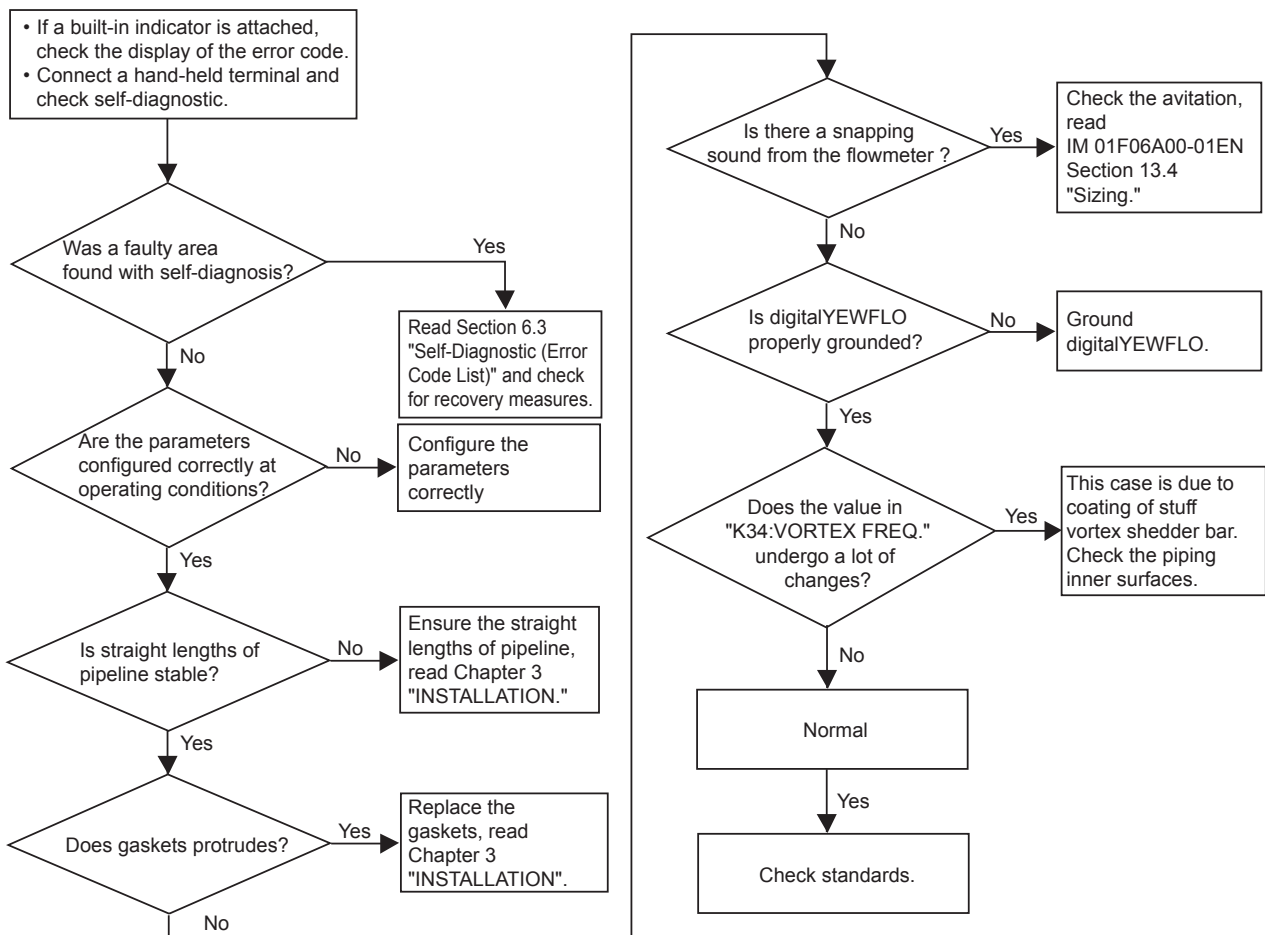
# 9. ERRORS AND COUNTERMEASURES FOR DISPLAY UNIT AND BRAIN PROTOCOL

Read IM 01F06A00-01EN Chapter 11 for "MAINTENANCE".



Please avoid replacing the amplifier unit from the case, and the vortex shedder bar. When these procedures are needed, please contact the nearest Yokogawa office.

## 9.1 Large Errors or Unstable Output



**Note 1:** This is the temperature and pressure at digitalYEWFLO mounted place.  
**Note 2:** Contact with our service in case this is not carried out into the right statement.

F0901.ai

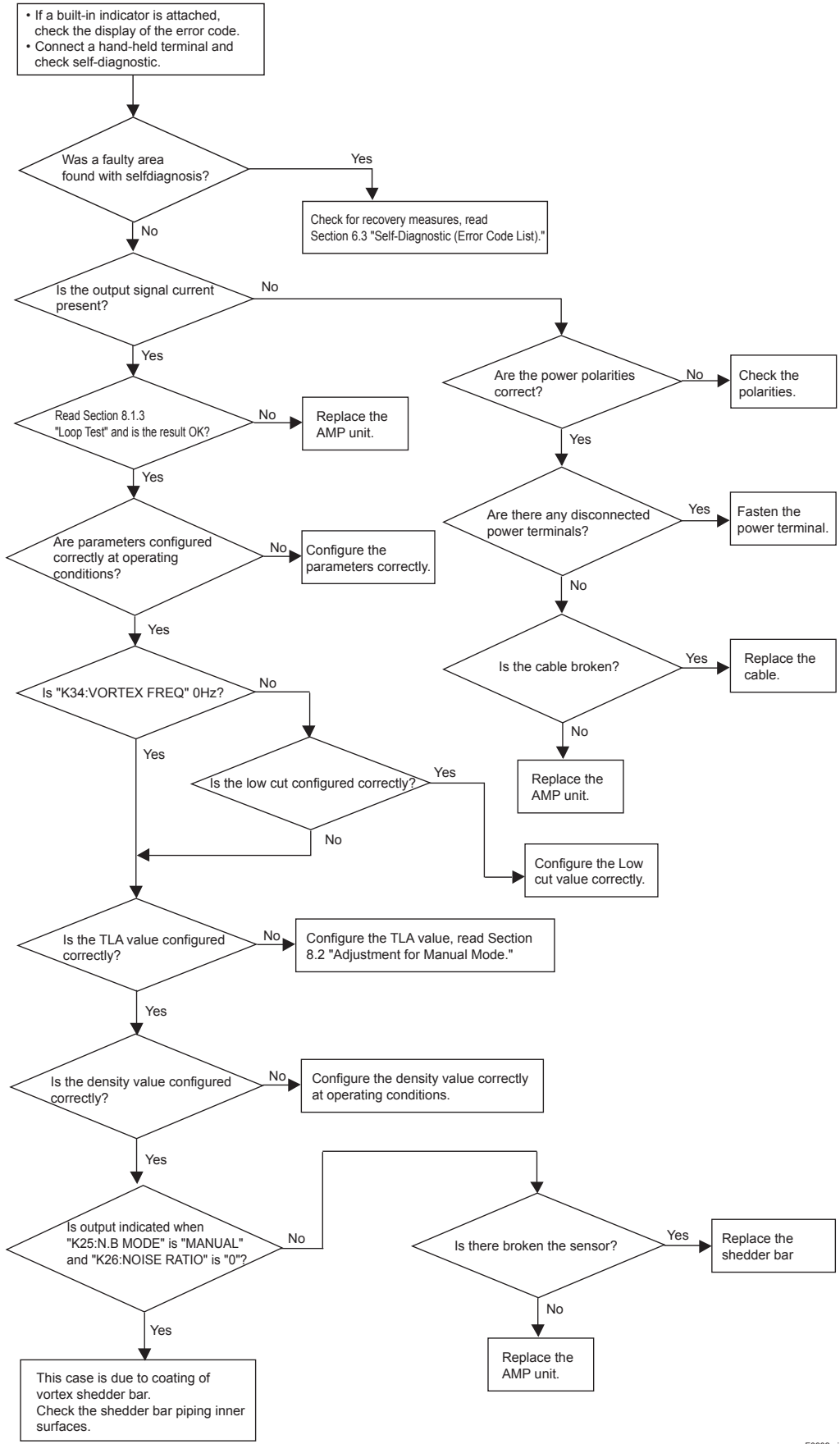
## 9.2 The Indication Goes to Zero at Certain Time

When this problem occurred, the cause is suspected of deterioration of sensor sensitivity and turbulent of fluid flow due to coating on the shedder bar and flowmeter inner tube.

### How to cope with this problem

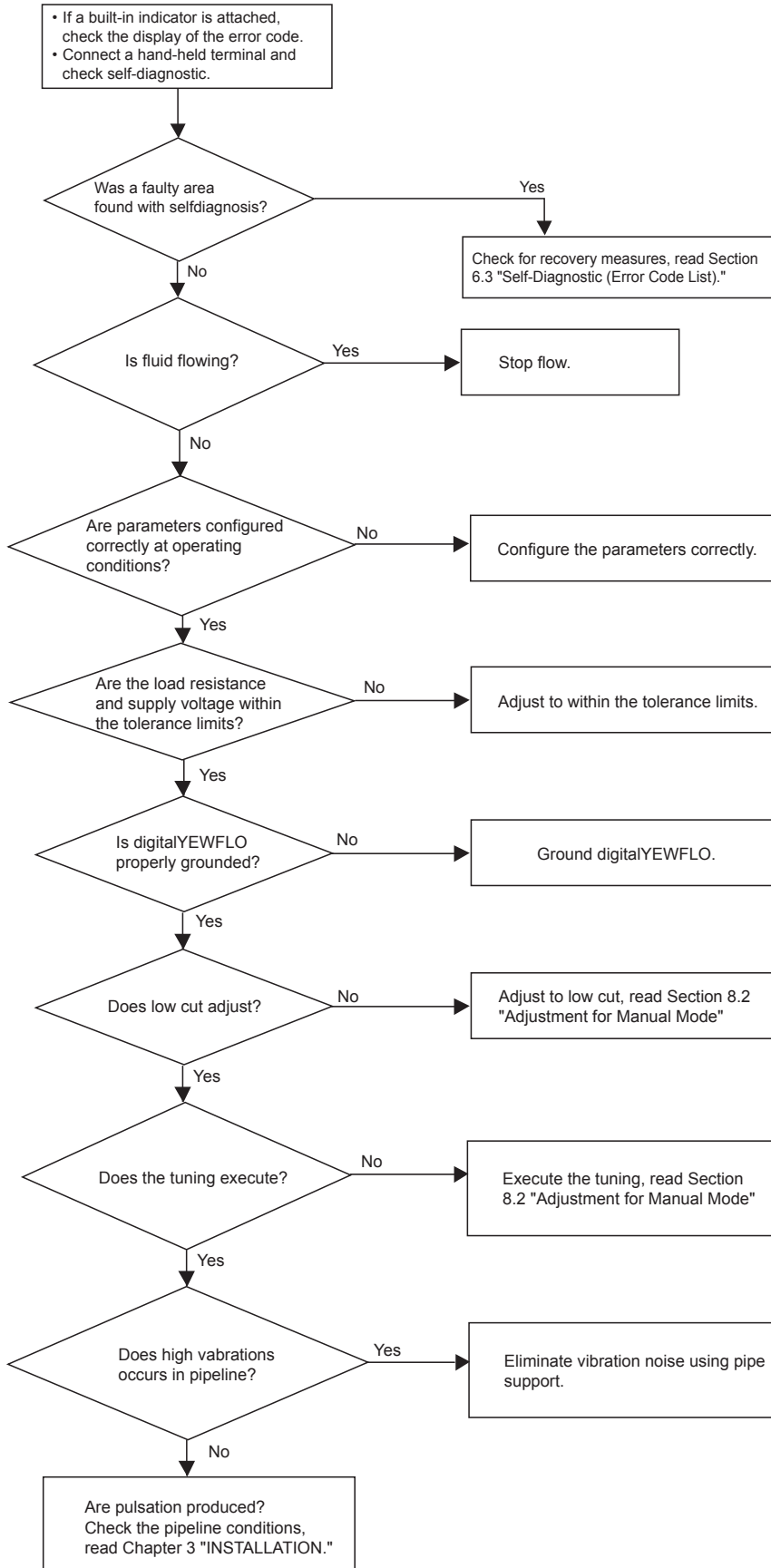
- 1) Read IM 01F06A00-01EN Section 11.5 "Vortex Shedder Removal," take out the Vortex Shedder bar and clean it.
- 2) If there is the coating on inner tube of the flowmeter, remove the flowmeter body from adjacent pipes and clean it.

### 9.3 No Output When The Fluid is Flowing



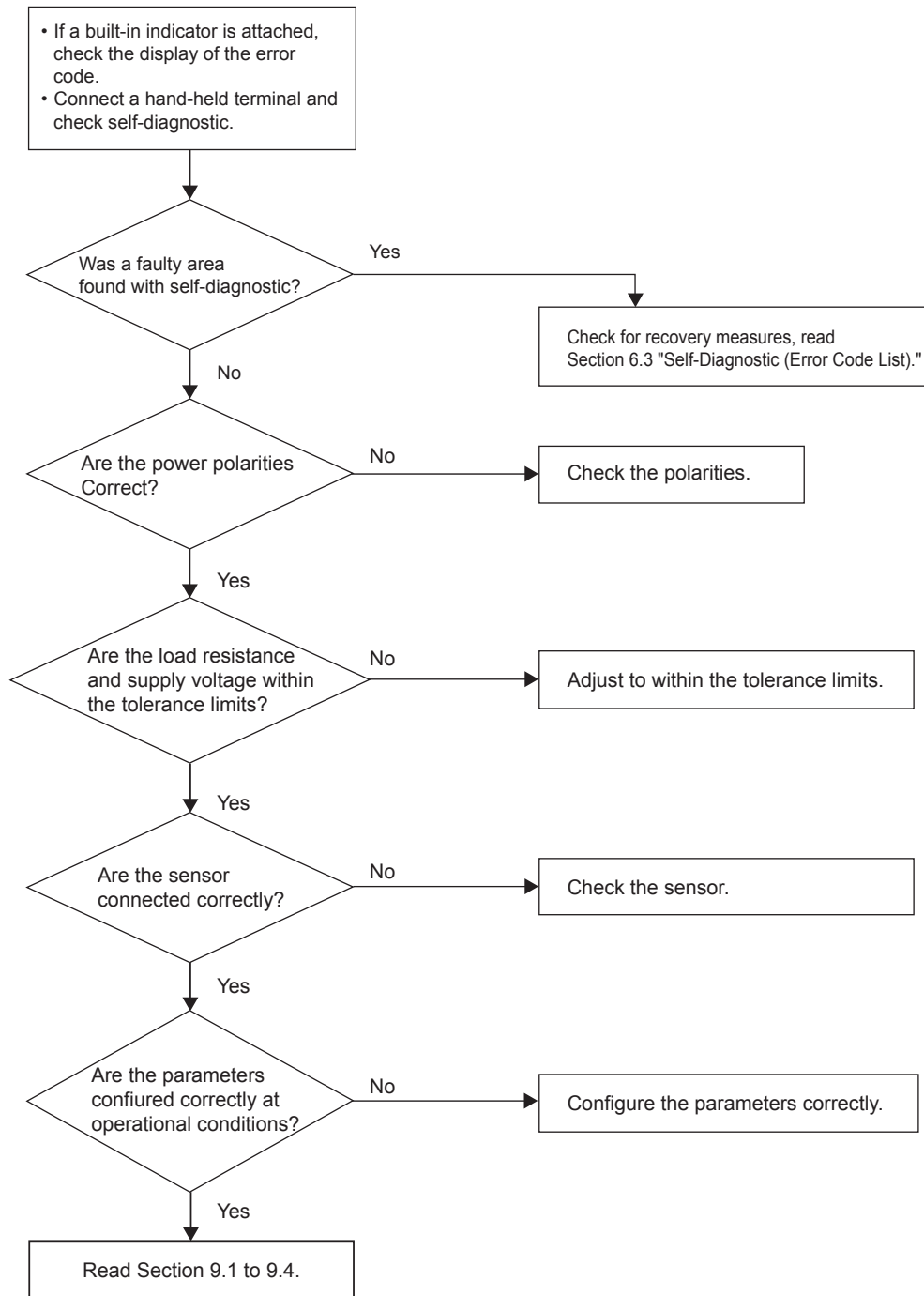
F0902.ai

### 9.4 Output is Indicated at Zero Flow



F0903.ai

### 9.5 Multi-Variable Type (/MV)



F0904.ai

# 10. EXPLOSION PROTECTED TYPE INSTRUMENT



## NOTE

- Read Chapter 12 for Fieldbus Communication Type Intrinsically safe approval.

In this chapter, further requirements and differences for explosion protected type instrument are described. For explosion protected type, the description in this chapter is prior to other description in this User's Manual.



## WARNING

- Only trained persons use this instrument in industrial locations.



## CAUTION

- Process temperature and ambient temperature on this section are the specifications for explosion protected type. Read IM 01F06A00-01EN Section 13.1 "Standard Specifications" before operating.

### 10.1 ATEX



## WARNING

- Only trained persons use this instrument in industrial locations.
- Electrostatic charge may cause an explosion hazard. Avoid any actions that cause the generation of electrostatic charge, such as rubbing with a dry cloth on coating face of product.

### (1) Technical Data

#### • Flameproof

Applicable Standard : EN 60079-0: 2009,  
EN 60079-1: 2007

Certificate : DEKRA 11ATEX0212X

Type of Protection:

Ex d IIC T6...T1 Gb (Integral Type and Remote Type Detector)

Ex d IIC T6 Gb (Remote Type Converter)

Group: II, Category: 2 G

Specification of Protection:

Temperature Class: (Integral Type and Remote Type Detector)

Temperature Class	Process Temperature
T6	-40°C to +80°C
T5	-40°C to +100°C
T4	-40°C to +135°C
T3	-40°C to +200°C
T2	-40°C to +300°C
T1	-40°C to +450°C

\*1 Note: Use /HT version above +250°C

Temperature Class: T6 (Remote Type Converter)

Ambient Temperature:

-30 to +60°C (With Indicator)

-40 to +60°C (Without Indicator)

Power Supply: 10.5 to 42Vdc max.

Output Signal: Current Output; 4 to 20mA

Pulse Output; On=2Vdc, 200mA

Off=42Vdc, 4mA

Special Fastener: Class A2-50 or more

#### • Intrinsically Safe

Applicable Standard: EN 60079-0: 2009,  
EN 60079-0: 2012,

EN 60079-11: 2012,

EN 60079-26: 2007

Certificate: DEKRA 13ATEX0192 X

Type of protection:

Ex ia IIC T4...T1 Ga (Integral Type)

Ex ia IIC T6...T1 Ga (Remote Type Detector)

Ex ia IIC T4 Ga (Remote Type Converter)

Group: II, Category: 2 G

Ambient Temperature:

-50 to +60°C (Integral Type)

-50 to +80 [+79]°C (Remote Type Detector)

(Option /LT below -29°C, [ ] for Option /MV at T6)

-50 to +80°C (Remote Type Converter)



Temperature Class:

(Integral Type)

Temperature Class	Process Temperature
T4	-50°C to +135°C
T3	-50°C to +199°C
T2	-50°C to +250°C
T1	-50°C to +250°C

(Remote Type Detector)

Temperature Class	Process Temperature *
T6	-196°C to +84/[+79]°C
T5	-196°C to +100°C
T4	-196°C to +135°C
T3	-196°C to +199°C
T2	-196°C to +299/[+289]°C
T1	-196°C to +449/[+439]°C

\*: Use /HT option above +250°C, use /LT option below -29°C, [] for /MV option.

Electrical data:

Supply and Output Circuit

(SUPPLY + and -, PULSE + and -);

Maximum Input Voltage  $U_i$ : 30Vdc

Maximum Input Current  $I_i$ : 300mA

(Read Contact rating for pulse output.)

Maximum Input Power  $P_i$ : 0.9 W

Internal Capacitance  $C_i$ : 14nF

Internal Inductance  $L_i$ : 0mH

Electrical Connection: ANSI 1/2 NPT female,

ISO M20 X 1.5 female

**Special conditions for safe use**

- Precautions shall be taken to minimize the risk from electrostatic discharge of painted parts.
- When the enclosure of the flow meter or the flow converter are made of aluminum, if it is mounted in an area where the use of EPL Ga equipment is required, it must be installed such that, even in the event of rare incidents, ignition sources due to impact and friction sparks are excluded.
- The dielectric strength of at least 500 V a.c. r.m.s. between the intrinsically safe circuits and the enclosure of the flow meter or the converter is limited only by the overvoltage protection.

**(2) Installation**

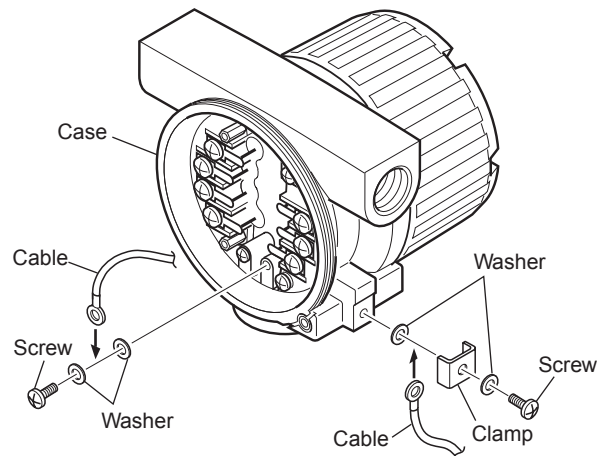


**WARNING**

- All wiring shall comply with local installation requirements and local electrical code.
- Use the suitable heat-resisting cables (over 90°C) for the digital YEWFL0 Series Vortex Flowmeter when the ambient temperature exceeds 60°C and/or the process temperature exceeds 200°C.
- Cable glands and adapters shall be of Ex “d” for Ex “d” installations.
- Cable glands and adapters shall be installed so as to maintain the specified degree of protection (IP Code) of the flowmeter.

The grounding terminals are located on the inside and outside of the terminal area.

Connect the cable to grounding terminal in accordance with wiring procedure (1) or (2).



(1) Internal grounding terminal (2) External grounding terminal F1001.ai

**Figure 10.1 Wiring Procedure for Grounding Terminals**

(3) Operation



**WARNING**

- In case of Flameproof, wait 3 min. after power is turned off, before opening the covers.
- Take care not to generate mechanical spark when access to the instrument and peripheral devices in hazardous locations.

(4) Maintenance and Repair

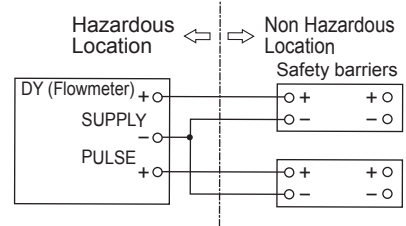


**WARNING**

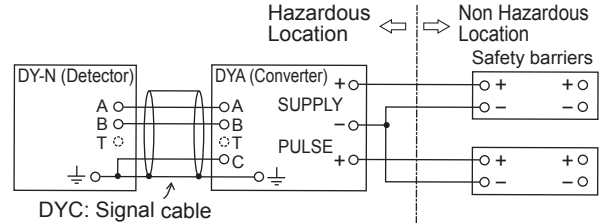
- The instrument modification or parts replacement by other than authorized representative of Yokogawa Electric Corporation is prohibited and will void the certification.

(5) Installation Diagram of Intrinsically safe (and Note)

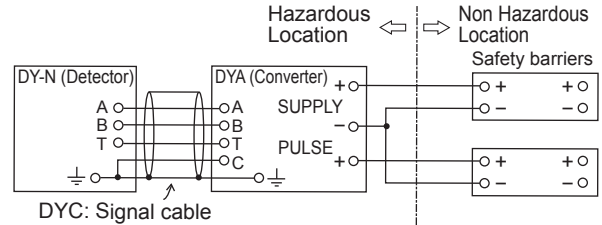
[Integral type]



[Remote type without built-in Temperature sensor]



[Remote type with built-in Temperature sensor]



Electrical data:

Signal/Supply Circuit (Terminals SUPPLY + and -):  
 $U_i = 30\text{ V}$ ,  $I_i = 300\text{ mA}$ ,  $P_i = 0.9\text{ W}$  (linear source),  
 $C_i = 14\text{ nF}$ ,  $L_i = 0\text{ mH}$

Pulse Circuit (Terminals PULSE + and -):  
 $U_i = 30\text{ V}$ ,  $I_i = 300\text{ mA}^*$ ,  $P_i = 0.9\text{ W}$  (linear source),  
 $C_i = 14\text{ nF}$ ,  $L_i = 0\text{ mH}$

\*: Read "Contact rating" for the maximum current value of Pulse Circuit

Note:

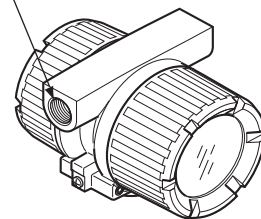
- It shall be assured that the voltage difference between the output circuits of the associated apparatus (safety barriers) is not more than 30V.
- Cables for the connection for Signal/Supply Circuit and Pulse Circuit shall be of Type A or B in accordance with EN 60079-14, otherwise the sum of  $I_o$  of the associated apparatus (safety barriers) shall be not more than 300 mA.

F1002.ai

(6) Electrical Connection

The type of electrical connection is stamped near the electrical connection port according to the following codes.

Screw size	Marking
ISO M20 X 1.5 female	M
ANSI 1/2-14NPT female	N



F1003.ai

(7) Name Plate

[Integral type, Flameproof]

digitalYEWFL0		OUTPUT	TAG NO.
VORTEX FLOWMETER		MWP	MPa at 38°C
MODEL	STYLE	PROCESS TEMP.	°C
SUFFIX		K-FACTOR	
		RANGE	
		NO.	
SUPPLY	V DC		
Yokogawa Electric Corporation TOKYO 180-8750 JAPAN YOKOGAWA Made in		AFTER DE-ENERGIZING DELAY 3 MINUTES BEFORE OPENING. THE PROCESS TEMP. > 200°C USE THE HEAT-RESISTING MIN. 100°C USE THE HEAT-RESISTING POTENTIAL ELECTROSTATIC CHARGING HAZARD - READ IM 01F06A01-01	

[Remote type detector, Flameproof]

digitalYEWFL0		OUTPUT	TAG NO.
VORTEX FLOWMETER		MWP	MPa at 38°C
MODEL	STYLE	PROCESS TEMP.	°C
SUFFIX		K-FACTOR	
		RANGE	
		NO.	
SUPPLY	V DC		
Yokogawa Electric Corporation TOKYO 180-8750 JAPAN YOKOGAWA Made in		AFTER DE-ENERGIZING DELAY 3 MINUTES BEFORE OPENING. THE PROCESS TEMP. > 200°C USE THE HEAT-RESISTING MIN. 100°C USE THE HEAT-RESISTING POTENTIAL ELECTROSTATIC CHARGING HAZARD - READ IM 01F06A01-01	

[Remote type converter, Flameproof]

digitalYEWFL0		OUTPUT	TAG NO.
VORTEX FLOW CONVERTER		MWP	MPa at 38°C
MODEL	STYLE	PROCESS TEMP.	°C
SUFFIX		K-FACTOR	
		RANGE	
		NO.	
SUPPLY	V DC		
Yokogawa Electric Corporation TOKYO 180-8750 JAPAN YOKOGAWA Made in		AFTER DE-ENERGIZING DELAY 3 MINUTES BEFORE OPENING. POTENTIAL ELECTROSTATIC CHARGING HAZARD - READ IM 01F06A01-01	

[Integral type, Intrinsically safe]

digitalYEWFL0		OUTPUT	TAG NO.
VORTEX FLOWMETER		4 - 20mA DC / PULSE	MPa at 38°C
MODEL	STYLE	PROCESS TEMP.	°C
SUFFIX		K-FACTOR	
		RANGE	
		NO.	
SUPPLY	10.5 - 30V DC		
Yokogawa Electric Corporation TOKYO 180-8750 JAPAN YOKOGAWA Made in		Ex ia IIC T4, T1 Ga No.: DEKRA 13ATEX0192 X Ex ia IIC T4, T1 Ga No.: DEKRA 13ATEX0192 X -50°C ≤ Ta ≤ +80°C Li=30V, I=300mA, Pi=0.9W, Ci=144F, Li=0mH POTENTIAL ELECTROSTATIC CHARGING HAZARD - READ IM 01F06A01-01	

[Remote type detector, Intrinsically safe]

digitalYEWFL0		OUTPUT	TAG NO.
VORTEX FLOWMETER		MWP	MPa at 38°C
MODEL	STYLE	PROCESS TEMP.	°C
SUFFIX		K-FACTOR	
		RANGE	
		NO.	
SUPPLY	V DC		
Yokogawa Electric Corporation TOKYO 180-8750 JAPAN YOKOGAWA Made in		AFTER DE-ENERGIZING DELAY 3 MINUTES BEFORE OPENING. POTENTIAL ELECTROSTATIC CHARGING HAZARD - READ IM 01F06A01-01	

[Remote type converter, Intrinsically safe]

digitalYEWFL0		OUTPUT	TAG NO.
VORTEX FLOW CONVERTER		4 - 20mA DC / PULSE	MPa at 38°C
MODEL	STYLE	PROCESS TEMP.	°C
SUFFIX		K-FACTOR	
		RANGE	
		NO.	
SUPPLY	10.5 - 30V DC		
Yokogawa Electric Corporation TOKYO 180-8750 JAPAN YOKOGAWA Made in		AFTER DE-ENERGIZING DELAY 3 MINUTES BEFORE OPENING. POTENTIAL ELECTROSTATIC CHARGING HAZARD - READ IM 01F06A01-01	

- MODEL: Specified model code
- SUFFIX: Specified suffix code
- STYLE: Style code
- SUPPLY: Supply voltage
- OUTPUT: Output signal
- MWP: Maximum working pressure
- PROCESS TEMP.: Process temperature
- K-FACTOR: Device-specific factor
- RANGE: Specified range
- NO.: Upper column: Manufacturing serial number \*1  
Lower column: The year / month of production
- TAG NO.: Specified TAG No.
- CE: CE marking
- 0344: The identification number of the notified body.
- II1G: Group II Category 1 Gas atmosphere
- II2G: Group II Category 2 Gas atmosphere
- II3G: Group II Category 3 Gas atmosphere

\*1) The first number in the second block of "NO." column is the last one number of the production year. For example, the year of production of the product engraved as follows is year 2015.

NO. S5K965926 535 7  
↑Produced in 2015

\*2) The product - producing country

## 10.2 FM

### (1) Technical Data

- **Explosion Proof**

Applicable Standard: CLASS 3600 2011,  
CLASS 3611 2004,  
CLASS 3615 2006,  
CLASS 3810 1989,  
Including Supplement 1 1995,  
NEMA 250 1991

Type of Protection:  
Explosionproof for Class I, Division 1,  
Groups A,B, C and D;  
Dust-ignition proof for Class II/III, Division 1,  
Groups E, F,and G.

“SEAL ALL CONDUITS 18 INCHES.”  
“WHEN INSTALLED IN DIV.2, SEALS NOT  
REQUIRED”

Enclosure Rating: Type 4X  
Temperature Code: T6  
Ambient Temperature:  
-40 to +60°C (Integral Type and Remote Type  
Detector)

-40 to +60°C (Remote Type Converter)  
Power Supply: 42Vdc max. (Integral Type and  
Remote Type Converter)

Output Signal (Integral Type):  
Current Output; 4 to 20mAdc  
Pulse Output; On=2Vdc, 200mA  
Off=42Vdc, 4mA

Output Signal (Remote Type Detector):  
Output Signal to Converter; 30Vp-p,  
100µAp-p

Input/Output Signal (Remote Type Converter):  
Current Output; 4 to 20mAdc  
Pulse Output; On=2Vdc, 200mA  
Off=42Vdc, 4mA  
Input Signal from Flowmeter;  
30Vp-p, 100µAp-p

Electrical connection : ANSI 1/2 NPT female

- **Intrinsically Safe**

Applicable Standard: CLASS 3600 1998,  
CLASS 3610 2010,  
CLASS 3611 2004,  
CLASS 3810 2005,  
NEMA 250 1991,  
ANSI/ISA-60079-0: 2009,  
ANSI/ISA-60079-11: 2009

Type of Protection:  
Intrinsically safe for Class I, II, III, Div.1, Groups  
A, B, C, D, E, F and G, T4 and Class I, Zone 0,  
AEx ia IIC T4 Nonincendive for Class I, II, Div. 2,  
Groups A, B, C, D, F and G, Class III, Div.1, T4,  
and Class I, Zone 2, Group IIC, T4

Ambient Temperature:  
-40 to +60°C (Integral Type and Remote Type  
Converter)  
-40 to +80°C (Remote Type Detector)

Indoors and Outdoors: Type 4X  
Electrical Parameters: Vmax=30Vdc,  
Imax=165mAdc,  
Pi=0.9W, Ci=12nF,  
Li=0.15mH

Electrical connection : ANSI 1/2 NPT female

### (2) Wiring

- **Explosion proof**



#### WARNING

- All wiring shall comply with National  
Electrical Code ANSI/NFPA 70 and Local  
Electrical Code.
- “SEAL ALL CONDUITS 18 INCHES”  
“WHEN INSTALLED DIV.2, SEALS NOT  
REQUIRED”.

- **Intrinsically Safe**



#### NOTE

- For using a hand-held terminal in the  
hazardous area, read the Control Drawing or  
Instruction Manual of handheld terminal.

### (3) Operation

- Explosion proof



#### **WARNING**

---

- In case of Explosion protected type, note a warning label worded as follows.  
Warning: OPEN CIRCUIT BEFORE  
REMOVING COVER.  
INSTALL IN ACCORDANCE WITH  
THE INSTRUCTION MANUAL (IM)  
01F06A00-01EN.
  - Take care not to generate mechanical spark when access to the instrument and peripheral devices in hazardous locations.
- 

### (4) Maintenance and Repair



#### **WARNING**

---

- The instrument modification or part replacements by other than authorized representative of Yokogawa Electric Corporation is prohibited and will void the approval of FM Approvals.
-

(5) Control Drawing

Model: DY Series

Date: April 16, 2001

12. Drawings

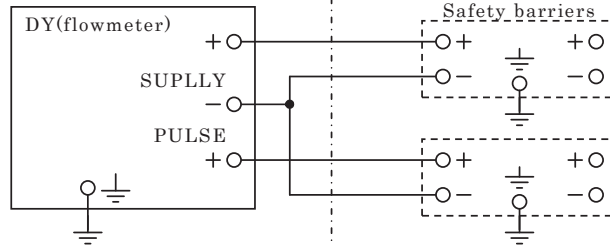
12.1 Installation Diagram

Intrinsically safe

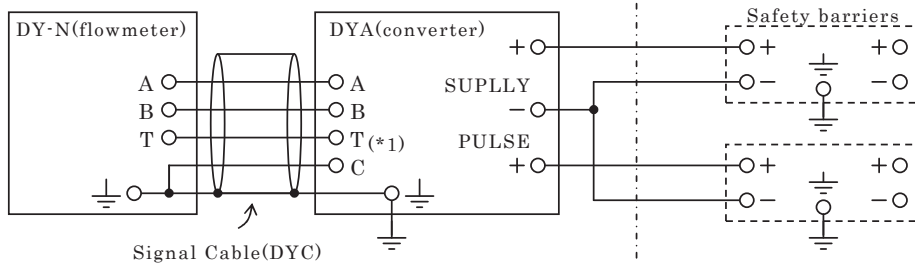
Hazardous Location ← → Non Hazardous Location

Class I, II, III, Division 1,  
Groups A,B,C,D,E,F and G,  
and Class I, Zone 0, Group IIC

[Integral type]



[Remote type]



(\*1) Wire for T terminal  
With temperature sensor type : installed  
Without temperature sensor type : not installed

Electrical parameters of vortex flowmeter(DY) and vortex flow converter(DYA).  
 $V_{max}=30\text{ V}$        $I_{max}=165\text{mA}$        $P_i=0.9\text{W}$   
 $C_i=12\text{nF}$        $L_i=0.15\text{mH}$

Installation requirements between flowmeter, converter and Safety Barrier

Rev1  $V_t \text{ or } V_{oc} \leq V_{max}$        $I_t \text{ or } I_{sc} \leq I_{max}$        $P_o \leq P_i$   
 $C_a \geq C_i + C_{cable}$        $L_a \geq L_i + L_{cable}$

$V_t, V_{oc}, I_t, I_{sc}, P_o, C_a$  and  $L_a$  are parameters of safety barrier.

Note :

1. In any safety barrier used output current must be limited by a resistor 'R' such that  $I_{sc}=V_{oc}/R$ .
- Rev2 2. Any Single FM Approved Barrier of multiple barriers FM Approved for this configuration who's parameters meet the above installation requirements.
3. Input voltage of the safety barrier must be less than  $250V_{rms}/V_{dc}$ .
- Rev2 4. Installation should be in accordance with National Electrical Code, ANSI/NFPA 70.
5. Dust-tight conduit seal must be used when installed in class II and III environments.
6. Do not alter drawing without authorization from FM.

Rev.1 :October 19, 2001 Y. Yamamoto  
 Rev.2 :November 5, 2001 Y.Yamamoto

Doc. No.: IFM019-A12 P.1  
 Drawing: Y. Yamamoto  
 Approved: K. Ichikawa

Yokogawa Electric Corporation

IFM019

Model: DY Series

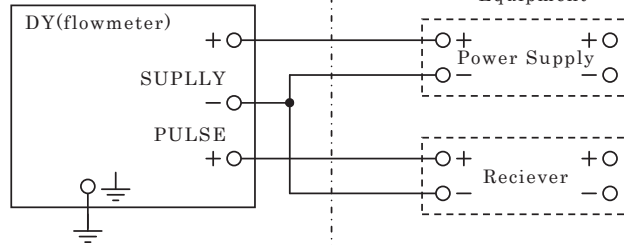
Date: April 16, 2001

Nonincendive

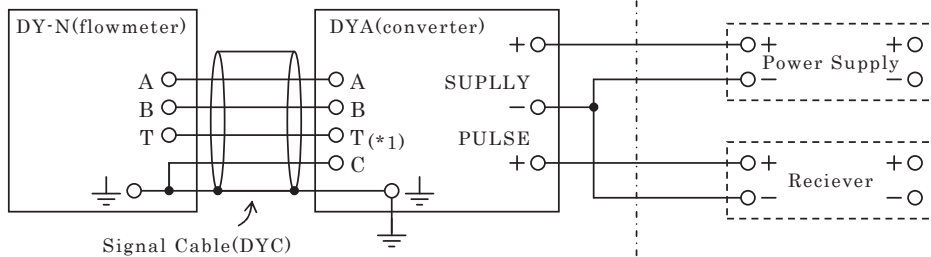
Hazardous Location ← → Non Hazardous Location

Class I,II, Division 2,  
Groups A,B,C,D,F and G,  
Class III, Division 1,  
and Class I, Zone 2, Group IIC

[Integral type]



[Remote type]



(\*1) Wire for T terminal  
With temperature sensor type : installed  
Without temperature sensor type : not installed

Non-incendive field wire parameters of vortex flowmeter(DY) and vortex flow converter(DYA).

$V_{max}=30\text{ V}$                        $I_{max}=165\text{mA}$                        $P_i=0.9\text{W}$   
 $C_i=12\text{nF}$                                $L_i=0.15\text{mH}$

Installation requirements between flowmeter, converter and general purpose equipment.

[Rev1]  $V_t \text{ or } V_{oc} \leq V_{max}$                        $I_t \text{ or } I_{sc} \leq I_{max}$                        $P_o \leq P_i$   
 $C_a \geq C_i + C_{cable}$                                $L_a \geq L_i + L_{cable}$

$V_t$ ,  $V_{oc}$ ,  $I_t$ ,  $I_{sc}$ ,  $P_o$ ,  $C_a$  and  $L_a$  are nonincendive field wire parameters of general purpose equipment.

Note :

- [Rev2] 1. The general purpose equipment must be FM Approved with Nonincendive field wiring parameter which meet the above installation requirements.
- [Rev2] 2. Installation should be in accordance with National Electric Code, ANSI/NFPA 70.
- 3. Dust-tight conduit seal must be used when installed in class II and III environments.
- 4. Do not alter drawing without authorization from FM.

Rev.1 :October 19, 2001 Y. Yamamoto  
Rev.2 :November 5, 2001 Y.Yamamoto

Doc. No.: IFM019-A12 P.2  
Drawing: Y. Yamamoto  
Approved: K. Ichikawa

Yokogawa Electric Corporation

IFM019

### 10.3 IECEX



#### WARNING

- Only trained persons use this instrument in industrial locations.
- Electrostatic charge may cause an explosion hazard.  
Avoid any actions that cause the generation of electrostatic charge, such as rubbing with a dry cloth on coating face of product.

#### (1) Technical Data

• **Flameproof**

Applicable Standard : IEC 60079-0: 2007,  
IEC 60079-1: 2007

Certificate : IECEX DEK 11.0077X

Type of Protection:

Ex d IIC T6...T1 Gb (Integral Type and Remote Type Detector)

Ex d IIC T6 Gb (Remote Type Converter)

Specification of Protection:

Temperature Class: (Integral Type and Remote Type Detector)

Temperature Class	Process Temperature
T6	-40°C to +80°C
T5	-40°C to +100°C
T4	-40°C to +135°C
T3	-40°C to +200°C
T2	-40°C to +300°C
T1	-40°C to +450°C

\*1 Note: Use /HT version above +250°C

Temperature Class: T6 (Remote Type Converter)

Ambient Temperature:

-30 to +60°C (With indicator)

-40 to +60°C (Without indicator)

Power Supply: 10.5 to 42Vdc max.

Output Signal: Current Output; 4 to 20mA  
Pulse output; On=2Vdc, 200mA  
Off=42Vdc, 4mA

Special Fastener: Class A2-50 or more

• **Intrinsically Safe**

Applicable Standard: IEC 60079-0: 2011,  
IEC 60079-11: 2011,  
IEC 60079-26: 2006

Certificate: IECEX DEK 13.0066X

Type of protection:

Ex ia IIC T4...T1 Ga (Integral Type)

Ex ia IIC T6...T1 Ga (Remote Type Detector)

Ex ia IIC T4 Ga (Remote Type Converter)

Ambient Temperature:

-50 to +60°C (Integral Type)

-50 to +80 [+79]°C (Remote Type Detector)

(Option /LT below -29°C, [ ] for Option /MV at T6)

-50 to +80°C (Remote Type Converter)

Temperature Class:

(Integral Type)

Temperature Class	Process Temperature
T4	-50°C to +135°C
T3	-50°C to +199°C
T2	-50°C to +250°C
T1	-50°C to +250°C

(Remote Type Detector)

Temperature Class	Process Temperature *
T6	-196°C to +84/[+79]°C
T5	-196°C to +100°C
T4	-196°C to +135°C
T3	-196°C to +199°C
T2	-196°C to +299/[+289]°C
T1	-196°C to +449/[+439]°C

\*: Use /HT option above +250°C, use /LT option below -29°C, [ ] for /MV option.

Electrical data:

Supply and Output Circuit

(SUPPLY + and -, PULSE + and -);

Maximum Input Voltage Ui: 30 V dc

Maximum Input Current Ii: 300 mA

(Read Contact rating for pulse output.)

Maximum Input Power Pi: 0.9 W

Internal Capacitance Ci: 14nF

Internal Inductance Li: 0mH

Electrical Connection: ANSI 1/2 NPT female,  
ISO M20 X 1.5 female



**Special conditions for safe use**

- Precautions shall be taken to minimize the risk from electrostatic discharge of painted parts.
- When the enclosure of the flow meter or the flow converter are made of aluminum, if it is mounted in an area where the use of EPL Ga equipment is required, it must be installed such that, even in the event of rare incidents, ignition sources due to impact and friction sparks are excluded.
- The dielectric strength of at least 500 V a.c. r.m.s. between the intrinsically safe circuits and the enclosure of the flow meter or the converter is limited only by the overvoltage protection.

**(2) Installation**

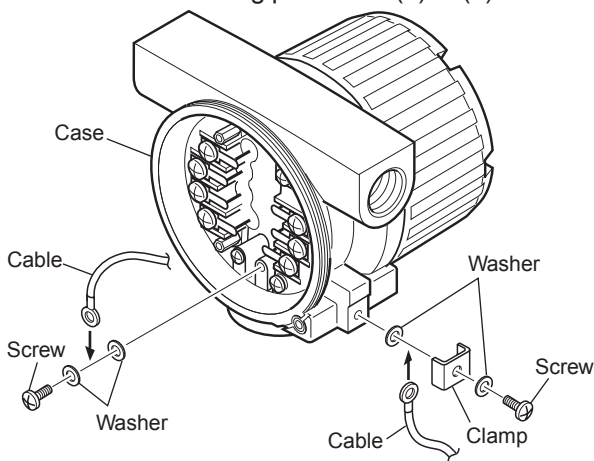


**WARNING**

- All wiring shall comply with local installation requirements and local electrical code.
- Use the suitable heat-resisting cables (over 90°C) for the digital YEWFL0 Series Vortex Flowmeter when the ambient temperature exceeds 60°C and/or the process temperature exceeds 200°C.
- Cable glands and adapters shall be of Ex “d” for Ex “d” installations.
- Cable glands and adapters shall be installed so as to maintain the specified degree of protection (IP Code) of the flowmeter.

The grounding terminals are located on the inside and outside of the terminal area.

Connect the cable to grounding terminal in accordance with wiring procedure (1) or (2).



(1) Internal grounding terminal    (2) External grounding terminal  
F1004.ai

**Figure 10.2 Wiring Procedure for Grounding Terminals**

**(3) Operation**



**WARNING**

- In case of Flameproof, wait 3 min. after power is turned off, before opening the covers.
- Take care not to generate mechanical spark when access to the instrument and peripheral devices in hazardous locations.

**(4) Maintenance and Repair**

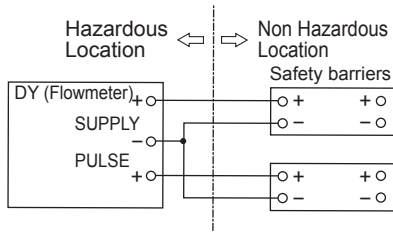


**WARNING**

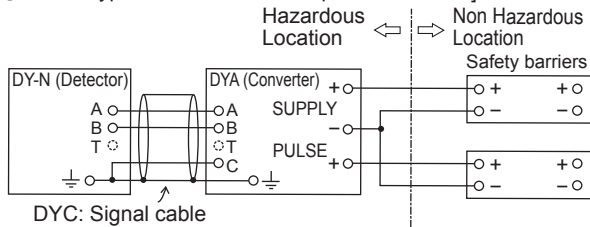
- The instrument modification or parts replacement by other than authorized representative of Yokogawa Electric Corporation is prohibited and will void the certification.

**(5) Installation Diagram of Intrinsically safe (and Note)**

[Integral type]

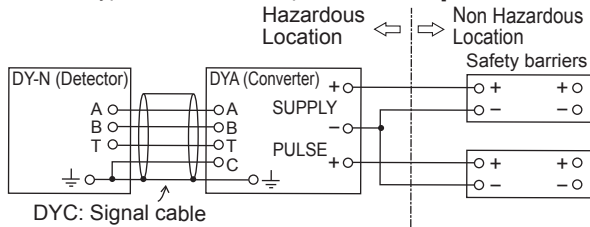


[Remote type without built-in Temperature sensor]



DYC: Signal cable

[Remote type with built-in Temperature sensor]



DYC: Signal cable

Electrical data:

Signal/Supply Circuit (Terminals SUPPLY + and -):  
 $U_i = 30\text{ V}$ ,  $I_i = 300\text{ mA}$ ,  $P_i = 0.9\text{ W}$  (linear source),  
 $C_i = 14\text{ nF}$ ,  $L_i = 0\text{ mH}$

Pulse Circuit (Terminals PULSE + and -):  
 $U_i = 30\text{ V}$ ,  $I_i = 300\text{ mA}^*$ ,  $P_i = 0.9\text{ W}$  (linear source),  
 $C_i = 14\text{ nF}$ ,  $L_i = 0\text{ mH}$

\*: Read "Contact rating" for the maximum current value of Pulse Circuit

Note:

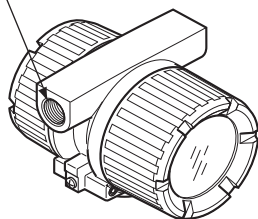
- It shall be assured that the voltage difference between the output circuits of the associated apparatus (safety barriers) is not more than 30V.
- Cables for the connection for Signal/Supply Circuit and Pulse Circuit shall be of Type A or B in accordance with IEC 60079-14, otherwise the sum of  $I_o$  of the associated apparatus (safety barriers) shall be not more than 300 mA.

F1005.ai

**(6) Electrical Connection**

The type of electrical connection is stamped near the electrical connection port according to the following codes.

Screw size	Marking
ISO M20 X 1.5 female	⚠ M
ANSI 1/2-14NPT female	⚠ N



F1006.ai

**(7) Name Plate**

[Integral type, Flameproof]

digitalYEWFL0		OUTPUT	TAG NO.
MODEL	VORTEX FLOWMETER	MWP	MPa at 38°C
SUFFIX	STYLE	PROCESS TEMP.	°C
		K-FACTOR	
		RANGE	
		NO.	
SUPPLY		V DC	

Yokogawa Electric Corporation  
 TOKYO 180-8750 JAPAN  
**YOKOGAWA** ◆2  
 Made in

⚠ AFTER DE-ENERGIZING, DELAY 3 MINUTES BEFORE OPENING. THE PROCESS TEMP. ≥ 200°C. USE THE HEAT-RESISTING CABLE AND LAYER GLAND. ⚠ POTENTIAL ELECTROSTATIC CHARGING HAZARD - READ IM 01F06A01-01

[Remote type detector, Flameproof]

digitalYEWFL0		OUTPUT	TAG NO.
MODEL	VORTEX FLOWMETER	MWP	MPa at 38°C
SUFFIX	STYLE	PROCESS TEMP.	°C
		K-FACTOR	
		RANGE	
		NO.	
SUPPLY		V DC	

Yokogawa Electric Corporation  
 TOKYO 180-8750 JAPAN  
**YOKOGAWA** ◆2  
 Made in

⚠ AFTER DE-ENERGIZING, DELAY 3 MINUTES BEFORE OPENING. THE PROCESS TEMP. ≥ 200°C. USE THE HEAT-RESISTING CABLE AND LAYER GLAND. ⚠ POTENTIAL ELECTROSTATIC CHARGING HAZARD - READ IM 01F06A01-01

[Remote type converter, Flameproof]

digitalYEWFL0		OUTPUT	TAG NO.
MODEL	VORTEX FLOW CONVERTER	MWP	MPa at 38°C
SUFFIX	STYLE	PROCESS TEMP.	°C
		K-FACTOR	
		RANGE	
		NO.	
SUPPLY		V DC	

Yokogawa Electric Corporation  
 TOKYO 180-8750 JAPAN  
**YOKOGAWA** ◆2  
 Made in

⚠ AFTER DE-ENERGIZING, DELAY 3 MINUTES BEFORE OPENING. THE PROCESS TEMP. ≥ 200°C. USE THE HEAT-RESISTING CABLE AND LAYER GLAND. ⚠ POTENTIAL ELECTROSTATIC CHARGING HAZARD - READ IM 01F06A01-01

[Integral type, Intrinsically safe]

digitalYEWFL0		OUTPUT	TAG NO.
MODEL	VORTEX FLOWMETER	MWP	MPa at 38°C
SUFFIX	STYLE	PROCESS TEMP.	°C
		K-FACTOR	
		RANGE	
		NO.	
SUPPLY		V DC	

Yokogawa Electric Corporation  
 TOKYO 180-8750 JAPAN  
**YOKOGAWA** ◆2  
 Made in

⚠ POTENTIAL ELECTROSTATIC CHARGING HAZARD - READ IM 01F06A01-01

[Remote type detector, Intrinsically safe]

digitalYEWFL0		OUTPUT	TAG NO.
MODEL	VORTEX FLOWMETER	MWP	MPa at 38°C
SUFFIX	STYLE	PROCESS TEMP.	°C
		K-FACTOR	
		RANGE	
		NO.	
SUPPLY		V DC	

Yokogawa Electric Corporation  
 TOKYO 180-8750 JAPAN  
**YOKOGAWA** ◆2  
 Made in

⚠ POTENTIAL ELECTROSTATIC CHARGING HAZARD - READ IM 01F06A01-01

[Remote type converter, Intrinsically safe]

digitalYEWFL0		OUTPUT	TAG NO.
MODEL	VORTEX FLOW CONVERTER	MWP	MPa at 38°C
SUFFIX	STYLE	PROCESS TEMP.	°C
		K-FACTOR	
		RANGE	
		NO.	
SUPPLY		V DC	

Yokogawa Electric Corporation  
 TOKYO 180-8750 JAPAN  
**YOKOGAWA** ◆2  
 Made in

⚠ POTENTIAL ELECTROSTATIC CHARGING HAZARD - READ IM 01F06A01-01

MODEL: Specified model code

SUFFIX: Specified suffix code

STYLE: Style code

SUPPLY: Supply voltage

OUTPUT: Output signal

MWP: Maximum working pressure

PROCESS TEMP.: Process temperature

K-FACTOR: Device-specific factor

RANGE: Specified range

NO.: Upper column: Manufacturing serial number \*1

Lower column: The year / month of production

TAG NO.: Specified TAG No.

I11G: Group II Category 1 Gas atmosphere

I12G: Group II Category 2 Gas atmosphere

I13G: Group II Category 3 Gas atmosphere

\*1) The first number in the second block of "NO." column is the last one number of the production year. For example, the year of production of the product engraved as follows is year 2015.

NO. S5K965926 535 7

↑Produced in 2015

\*2) The product - producing country

### 10.4 CSA

#### (1) Technical Data

• **Explosion Proof**

Applicable Standard: C22.1-98, C22.2 No.0-M1991, C22.2 No.0.4-04, C22.2 No.0.5-1982, C22.2 No. 25-1966, C22.2 No. 30-M1986, C22.2 No. 94-M1991, C22.2 No. 142-M1987, C22.2 No. 61010-1-04, ANSI/ISA-12.27.01-2003

Certificate: 1166201

Type of Protection:

Explosionproof for Class I, B, C and D; Class II, Groups E, F and G; Class III.

For Class I, Division 2 location:

“FACTORY SEALED, CONDUIT SEAL NOT REQUIRED.”

Enclosure : Type 4X

(Integral Type and Remote Type Detector)

Temperature Code	Process Temperature
T6	≤+85°C
T5	≤+100°C
T4	≤+135°C
T3	≤+200°C
T2	≤+300°C
T1	≤+450°C

Temperature Code: T6 (Remote Type Converter)

Ambient Temperature: -50 to +60°C

Power Supply: 42Vdc max. (Integral Type and Remote Type Converter)

Output Supply (Integral Type):

Current Output; 4 to 20mA

Pulse Output; On=2Vdc, 200mA  
Off=42Vdc, 4mA

Output Signal (Remote Type Detector):

Output Signal; 30Vp-p, 100µAp-p

Input/Output signal (Remote Type Converter):

Current Output; 4 to 20mA

Pulse; On=2Vdc, 20mA  
Off=42Vdc, 4mA

Input Signal; 30Vp-p, 100µAp-p

Electrical Connection: ANSI 1/2 NPT female

• **Intrinsically Safe**

**Type “n” and Non-incendive**

Applicable Standard: C22.2 No. 0-M91, C22.2 No. 0.4-2004, C22.2 No. 157-M1987, C22.2 No. 213-M1987, C22.2 No. 1010.1-92, CAN/CSA-E60079-0:02, CAN/CSA-E60079-11:02, CAN/CSA-E60079-15:02, ANSI/ISA-12.27.01-2003

Certificate: 1198227

Type of Protection:

Ex ia IIC T4...T1 and Ex nC IIC T4...T1  
(Integral Type and Remote Type Detector)

Ex ia IIC T4 and Ex nC IIC T4  
(Remote Type Converter)

(Integral Type and Remote Type Detector)

Temperature Code	Process Temperature
T4	≤+135°C
T3	≤+200°C
T2	≤+300°C
T1	≤+450°C

Ambient Temperature: -40 to +60°C

Degree of Protection of Enclosure: IP67

Electrical Parameters: Ui=30Vdc, Ii=165mA, Pi=0.9W

Ci=12nF, Li=0.15mH

Electrical Connection: ANSI 1/2 NPT female

Type of Protection:

Intrinsically Safe for Class I,II,III, Div.1, Groups A,B,C,D,E,F and G, Non- incendive for Class I,II, Div.2, Groups A,B,C,D,E,F and G, Class III, Div.1

(Integral Type and Remote Type Detector)

Temperature Code	Process Temperature
T4	≤+135°C
T3	≤+200°C
T2	≤+300°C
T1	≤+450°C

Temperature Code: T4 (Remote Type Converter)

Ambient Temperature: -40 to +60°C

Enclosure: Type 4X

Electrical Parameters: Vmax=30Vdc, Imax=165mA, Pmax=0.9W, Ci=12nF, Li=0.15mH

**(2) Wiring**

- Explosion proof



**WARNING**

- All wiring shall comply with Canadian Electrical Code Part I and Local Electrical Codes.
- In Hazardous locations, wiring shall be in conduit as shown in the figure.
- A SEAL SHALL BE INSTALLED WITHIN 50cm OF THE ENCLOSURE.
- When the equipment is installed in Division 2, "FACTORY SEALED, CONDUIT SEAL NOT REQUIRED".

**(3) Operation**

- Explosion proof



**WARNING**

- In case of Explosion protected type, note a warning label worded as follows.  
Warning: OPEN CIRCUIT BEFORE REMOVING COVER.
- Take care not to generate mechanical spark when access to the instrument and peripheral devices in hazardous locations.

**(4) Maintenance and Repair**

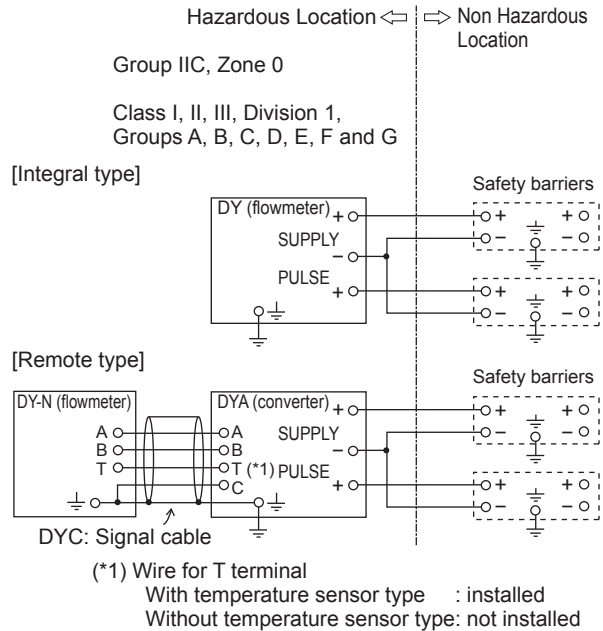


**WARNING**

- The instrument modification or part replacements by other than authorized representatives of Yokogawa Electric Corporation are prohibited and will void CSA Certification.

**(5) Installation Diagram Intrinsically Safe (and Note)**

**Intrinsically safe**



Electrical parameters of vortex flowmeter (DY) and vortex flow converter (DYA).

$U_i (V_{max})=30\text{ V}$      $I_i (I_{max})=165\text{ mA}$      $P_i (P_{max})=0.9\text{ W}$   
 $C_i=12\text{ nF}$                        $L_i=0.15\text{ mH}$

Installation requirements between flowmeter, converter and Safety Barrier

$U_o \leq U_i$      $I_o \leq I_i$      $P_o \leq P_i$      $C_o \geq C_i + C_{cable}$   
 $L_o \geq L_i + L_{cable}$   
 $V_{oc} \leq V_{max}$      $I_{sc} \geq I_{max}$      $C_a \geq C_i + C_{cable}$   
 $L_a \geq L_i + L_{cable}$

$U_o, I_o, P_o, C_o, L_o, V_{oc}, I_{sc}, C_a$  and  $L_a$  are parameters of barrier.

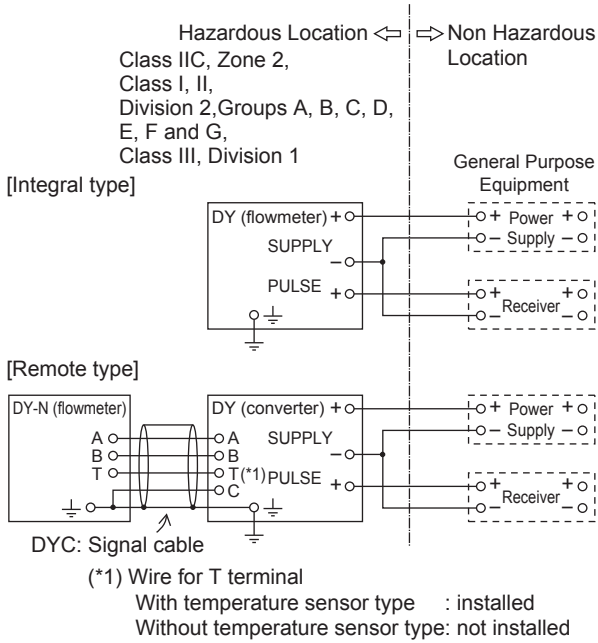
F1007.ai



**WARNING**

- In any safety barrier used output current must be limited by a resistor 'R' such that  $I_o=U_o/R$  or  $I_{sc}=V_{oc}/R$ .
- The safety barrier must be CSA certified.
- Input voltage of the safety barrier must be less than 250Vrms/Vdc.
- Installation should be in accordance with Canadian Electrical Code Part I.
- Dust-tight conduit seal must be used when installed in class II and III environments.
- Do not alter drawing without authorization from CSA.

**Type “n” and Non-incendive**



Non-incendive field wire parameters of vortex flowmeter (DY) and vortex flow converter (DYA).  
 $U_i (V_{max})=30$     $I_i (I_{max})=165mA$     $P_i (P_{max})=0.9W$   
 $C_i=12nF$     $L_i=0.15mH$

Installation requirement between flowmeter, converter and general purpose equipment.  
 $U_o \leq U_i$     $I_o \leq I_i$     $P_o \leq P_i$     $C_o \geq C_i + C_{cable}$   
 $L_o \geq L_i + L_{cable}$   
 $V_{oc} \leq V_{max}$     $I_{sc} \leq I_{max}$     $C_a \geq C_i + C_{cable}$   
 $L_a \geq L_i + L_{cable}$   
 $U_o, I_o, P_o, C_o, V_{oc}, I_{sc}, C_a$  and  $L_a$  are nonincendive field wire parameters of general purpose equipment.

F1008.ai



**WARNING**

- The general purpose equipment must be CSA certified as the equipment which have type n or non-incendive field wire parameters.
- Installation should be in accordance with Canadian Electrical Code Part I.
- Dust-tight conduit seal must be used when installed in class II and III environments.
- Do not alter drawing without authorization from CSA.

**(6) Dual Seal (Option code: /CF11, /CS11)**

Dual Seal:  
 Certified by CSA to the requirement of ANSI/ISA 12.27.01  
 No additional sealing required.  
 Primary seal failure annunciation: at the O-ring seal portion between shedder bar and amplifier housing.

## 10.5 TIIS

### Certificate:

Model	Shedder bar Material	Integral Type Flowmeter		Remote Type Detector
		N (None Indicator)	D (With Indicator)	N (None Indicator)
DY015 DY025/R1 DY040/R2	E	TC14901	TC14912	TC14923
	X	TC18903	TC18914	TC18925
DY025 DY040/R1 DY050/R2	E	TC19504	TC19513	TC19522
	X	TC18904	TC18915	TC18926
DY040 DY050/R1 DY080/R2	E	TC19505	TC19514	TC19523
	X	TC18905	TC18916	TC18927
DY050 DY080/R1 DY100/R2	E	TC19506	TC19515	TC19524
	X	TC18906	TC18917	TC18928
DY080 DY100/R1 DY150/R2	E	TC19507	TC19516	TC19525
	X	TC18907	TC18918	TC18929
DY100 DY150/R1 DY200/R2	E	TC19508	TC19517	TC19526
	X	TC18908	TC18919	TC18930
DY150 DY200/R1	E	TC19509	TC19518	TC19527
	X	TC18909	TC18920	TC18931
DY200	E	TC19510	TC19519	TC19528
	X	TC18910	TC18921	TC18932
DY250	E	TC19511	TC19520	TC19529
DY300	E	TC19512	TC19521	TC19530
DY400	B	TC18945	TC18955	TC18965
Model	Shedder bar Material	Remote Type Converter		
		N (None Indicator)	D (With Indicator)	
DYA		TC14934	TC14935	

	Integral Type Flowmeter		Remote Type Flowmeter	
	None Indicator	With Indicator	Detector	Converter
<b>Construction</b>	Ex d IIC T6	←	←	←
	Flame Proof Approval	←	←	←
<b>Amb.Temp</b>	-20°C up to +60°C	←	←	←
<b>Rating</b>	Maximum power supply vortage: DC42V Current Signal: DC4-20mA Pulse Signal: ON : 2V 200mA OFF : 42V 4mA		Output Voltage: 30Vp-p Output Current: 100µ Ap-p	Maximum power supply vortage: DC42V Current Signal: DC4-20mA Pulse Signal: ON : 2V 200mA OFF : 42V 4mA Input Signal: 30V p-p,100µ A p-p Resistance Temp, Sensor Input: Pt1000 at 0°C Specified Current: less than 1mA

\* In case that ambient temperature exceeds 50°C, use heat-resistant cables with maximum allowable temperature of 70°C or above.

# 11. COMMUNICATION (FIELDBUS)

Fieldbus is fully dependent upon digital communication protocol and differs in operation from conventional 4 to 20 mA transmission and the BRAIN communication protocol. It is recommended that novice users use fieldbus devices in accordance with the procedures described in this section. The procedures assume that fieldbus devices will be set up on a bench or in an instrument shop.

## 11.1 Amplifier for Fieldbus Communication Type

Read IM 01F06A00-01EN for the details of the amplifier. This section encompasses topics applicable to only the Fieldbus communication type.

- (1) The Fieldbus communication type has no local key access function.
- (2) The Fieldbus communication type has no BT200 (BRAIN TERMINAL) connection pin.
- (3) The Fieldbus communication type has a simulation function. The SIMULATE\_ENABLE switch is mounted on the amplifier. Read Section 11.6 “Simulation Function” for details of the simulation function.

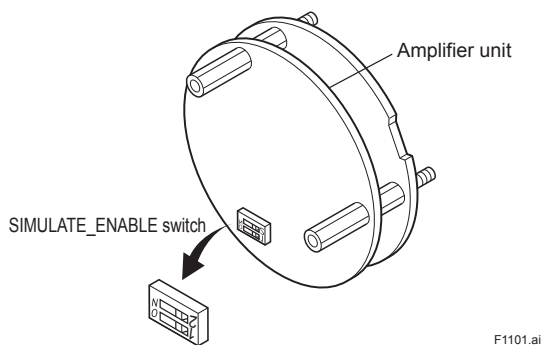


Figure 11.1 Amplifier for Fieldbus Communication

## 11.2 Connection of Devices

The following instruments are required for use with Fieldbus devices:

- **Power supply:**  
Fieldbus requires a dedicated power supply. It is recommended that current capacity be well over the total value of the maximum current consumed by all devices (including the host). Conventional DC current cannot be used as is.

- **Terminator:**  
Fieldbus requires two terminators. Read the supplier for details of terminators that are attached to the host.
- **Field devices:**  
Connect your Fieldbus communication type digitalYEWFL0 to a fieldbus. Two or more digitalYEWFL0s and other field devices can be connected. For the terminal assignment on the digitalYEWFL0, read Table 11.1.

Table 11.1 Terminal Connection for digitalYEWFL0

Terminal Symbols	Description
SUPPLY ⊕	Fieldbus Communication Signal Terminals
SUPPLY ⊖	
⏏	Grounding Terminal

- **Host:**  
Used for accessing field devices. A dedicated host (such as DCS) is used for an instrumentation line while dedicated communication tools are used for experimental purposes. For operation of the host, read the instruction manual for each host. No other details on the host are given in this manual.
- **Cable:**  
Used for connecting devices. Read “Fieldbus Technical Information” (TI 38K03A01-01E) for details of instrumentation cabling. For laboratory or other experimental use, a twisted pair cable two to three meters in length with a cross section of 0.9 mm<sup>2</sup> or more and a cycle period of within 5 cm (2 inches) may be used. Termination processing depends on the type of device being deployed. For the digitalYEWFL0, use terminal lugs applicable to M4 screw terminals. Some hosts require a connector.

Read Yokogawa when making arrangements to purchase the recommended equipment. Connect the devices as shown in Figure 11.2. Connect the terminators at both ends of the trunk, with a minimum length of the spur laid for connection. The polarity of signal and power must be maintained.

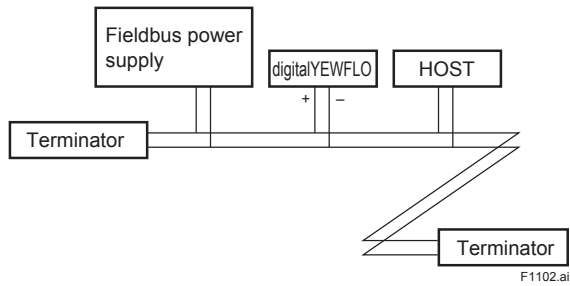


Figure 11.2 Device Connection



**IMPORTANT**

Connecting a Fieldbus configuration tool to a loop with its existing host may cause communication data scrambling resulting in a functional disorder or a system failure. Disconnect the relevant control loop from the bus if necessary.

**11.3 Host Setting**

To activate Fieldbus, the following settings are required for the host.

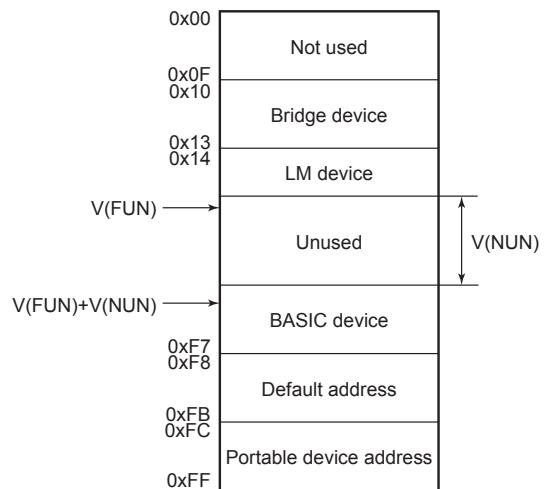


**IMPORTANT**

Do not turn off the power immediately after setting. When the parameters are saved to the EEPROM, the redundant processing is executed for the improvement of reliability. If the power is turned off within 60 seconds after setting is made, the modified parameters are not saved and the settings may return to the original values.

Table 11.2 Operation Parameters

Symbol	Parameter	Description and Settings
V (ST)	Slot-Time	Indicates the time necessary for immediate reply of the device. Unit of time is in octets (256 μs). Set maximum specification for all devices. For digital YEWFL0, set a value of 4 or greater.
V (MID)	Minimum-Inter-PDU-Delay	Minimum value of communication data intervals. Unit of time is in octets (256 μs). Set the maximum specification for all devices. For digital YEWFL0, set a value of 4 or greater.
V (MRD)	Maximum-Reply-Delay	The worst case time elapsed until a reply is recorded. The unit is Slot-time; set the value so that V (MRD) x V (ST) is the maximum value of the specification for all devices. For digital YEWFL0, the setting must be a value of 12 or greater.
V (FUN)	First-Unpolled-Node	Indicate the address next to the address range used by the host. Set 0x15 or greater.
V (NUN)	Number-of-consecutive-Unpolled-Node	Unused address range.



Note 1: LM device: with bus control function (Link Master function)  
 Note 2: BASIC device: without bus control function

F1103.ai

Figure 11.3 Available Address Range

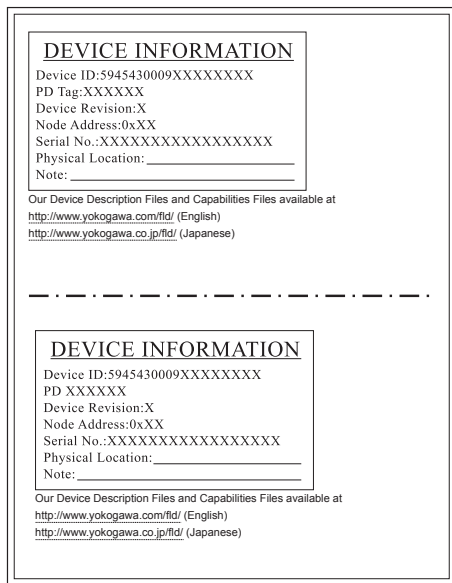


### 11.4 Power-on of digitalYEWFLO and Bus

Turn on the power to the host, bus, and digitalYEWFLO. If any segments do not light, or if a current anomaly occurs, check the voltage of the power supply for the digitalYEWFLO.

The device information, including PD tag, Node address, and Device ID, is described on the sheet attached to digitalYEWFLO. The device information is given in duplicate on this sheet.

Using the host device display function, check that the digitalYEWFLO is in operation on the bus.



F1104.ai

Figure 11.4 Device Information Sheet Attached to digitalYEWFLO

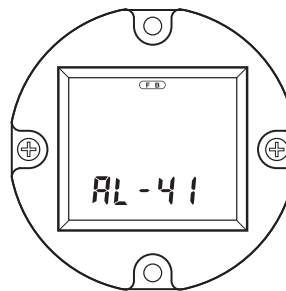
Unless otherwise specified, the following settings are in effect when shipped from the factory. If no digitalYEWFLO is detected, check the available address range. If the node address and PD Tag are not specified when ordering, default value is factory set. If two or more digitalYEWFLOs are connected at a time with default value, only one digitalYEWFLO will be detected from host as digitalYEWFLOs have the same initial address. Connect the digitalYEWFLOs one by one and set a unique address for each.

Read IM 01F06F00-01EN Chapter 4 for "GETTING STARTED", Chapter 5 for "CONFIGURATION" and Chapter 6 for "EXPLANATION OF BASIC ITEMS".

### 11.5 Generation of Alarm

#### 11.5.1 Indication of Alarm

When the self-diagnostics function indicates that a device is faulty, an alarm (device alarm) is issued from the resource block. When an error (block error) is detected in each function block or an error in the process value (process alarm) is detected, an alarm is issued from each block. If an LCD indicator is installed, the error number is displayed as AL-XX. If two or more alarms are issued, multiple error numbers are displayed in 2-second intervals. (when "1" is set to DISPLAY\_CYCLE).



F1105.ai

Figure 11.5 Error Identification on Indicator

The error details corresponding to alarm indications on the LCD indicator and whether or not switches are provided to disable the corresponding alarms are shown in Table 11.3. For the alarms for which an alarm mask switch is provided, the default alarm settings are also shown. Those alarms for which an alarm mask switch is not provided are enabled at all times. For how to modify these mask switch statuses, read IM 01F06F00-01EN APPENDIX 3 "OPERATION OF EACH PARAMETER IN FAILURE MODE."

**Table 11.3 Alarm Indications and Alarm Mask Switches**

LCD	Error Detail	Alarm Mask SW (default)
AL-01	The EEPROM(S) failed.	Not provided
AL-02	The serial communication circuit in the amplifier failed (type 1 error).	Not provided
AL-03	The serial communication circuit in the amplifier failed (type 2 error).	Not provided
AL-04	The EEPROM(F) failed.	Not provided
AL-05	The flow sensor failed.	Provided (ON)
AL-06	The input circuit in the amplifier failed.	Provided (ON) *
AL-07	The temperature circuit in the amplifier failed.	Not provided
AL-08	The temperature sensor failed.	Not provided
AL-20	No function blocks are scheduled.	Not provided
AL-21	Resource Block is in O/S mode.	Not provided
AL-22	Transducer Block is in O/S mode.	Not provided
AL-23	AI1 Block is in O/S mode.	Provided (ON)
AL-24	AI2 Block is in O/S mode.	Provided (OFF)
AL-25	DI1 Block is in O/S mode.	Provided (OFF)
AL-26	DI2 Block is in O/S mode.	Provided (OFF)
AL-27	PID Block is in O/S mode.	Provided (OFF)
AL-28	AI3 Block is in O/S mode.	Provided (OFF)
AL-29	IT Block is in O/S mode.	Provided (OFF)
AL-30	AR Block is in O/S mode.	Provided (OFF)
AL-41	Flow rate is over the range.	Not provided
AL-42	The flow rate span setting exceeds the range limit.	Not provided
AL-43	Temperature is over the range. (Regulated in the upper or lower limit value)	Not provided
AL-51	The transient vibration makes the current flow rate output constant.	Provided (OFF)
AL-52	The high vibration makes the current flow rate output zero.	Provided (OFF)
AL-53	The shedder bar is clogged with a material.	Provided (OFF)
AL-54	The current flow rate is fluctuating more than 20%.	Provided (OFF)
AL-61	Indicator is over the range.	Not provided
AL-62	AI1 Block is in Manual mode.	Provided (ON)
AL-63	AI1 Block is in simulation mode.	Provided (ON)
AL-64	AI1 Block is not scheduled.	Provided (ON)
AL-65	AI2 Block is in Manual mode.	Provided (OFF)
AL-66	AI2 Block is in simulation mode.	Provided (OFF)
AL-67	AI2 Block is not scheduled.	Provided (OFF)
AL-68	DI1 Block is in Manual mode.	Provided (OFF)
AL-69	DI1 Block is in simulation mode.	Provided (OFF)
AL-70	DI1 Block is not scheduled.	Provided (OFF)
AL-71	DI2 Block is in Manual mode.	Provided (OFF)
AL-72	DI2 Block is in simulation mode.	Provided (OFF)
AL-73	DI2 Block is not scheduled.	Provided (OFF)
AL-74	PID Block is in Bypass mode.	Provided (OFF)
AL-75	PID Block is failed (type 1 error).	Provided (OFF)
AL-76	PID Block is failed (type 2 error).	Provided (OFF)
AL-77	AI3 Block is in Manual mode.	Provided (OFF)
AL-78	AI3 Block is in simulation mode.	Provided (OFF)
AL-79	AI3 Block is not scheduled.	Provided (OFF)
AL-80	IT Block is in Manual mode.	Provided (OFF)
AL-81	IT Block is not scheduled.	Provided (OFF)
AL-82	IT Total backup failed. Last IT Output.Value (IT. OUT.Value) could not saved.	Provided (OFF)
AL-83	IT Clock Period (IT.CLOCK_PER) is smaller than IT Period of Execution(IT.EXECUTION_PERIOD).	Provided (OFF)
AL-84	AR Block is in Manual mode.	Provided (OFF)
AL-85	AR Block is not scheduled.	Provided (OFF)

LCD	Error Detail	Alarm Mask SW (default)
AL-86	AR Range High (AR.RANGE_HI) is smaller than AR Range Low (AR.RANGE_LOW).	Provided (OFF)
AL-87	AR Input1 (AR.IN_1) is over range.	Provided (OFF)
AL-88	AR Input2 (AR.IN_2) is over range.	Provided (OFF)
AL-89	AR Input (AR.IN) is not connected to the volumetric flow.	Provided (OFF)
AL-90	AR Input1 (AR.IN_1) is not connected to the temperature.	Provided (OFF)
AL-91	AR Input2 (AR.IN_2) is not connected to the pressure.	Provided (OFF)
AL-92	AR Compensation Coefficient (AR.AR_FLOW_CONFIG.Element) changed unexpectedly. Therefore AR Output (AR.OUT.Value) is uncertainty.	Provided (OFF)
AL-93	AR Output Range .Units Index (AR.OUT_RANGE.Unit Index) is not selected rightly the corresponding to AR Arithmetic Type (AR.ARITH_TYPE).	Provided (OFF)

\*: Not provided for a model with the option /MV and with the fluid density calculation set to be active.

### 11.5.2 Alarms and Events

Each digitalYEWFLO can report the following alarms and events as alerts.

**Analog Alerts** (Generated when a process value exceeds threshold)

By AI Block: Hi-Hi Alarm, Hi Alarm, Low Alarm, Low-Low Alarm

**Discrete Alerts** (Generated when an abnormal condition is detected)

By Resource Block: Block Alarm, Write Alarm  
 By Transducer Block: Block Alarm  
 By AI Block: Block Alarm  
 By PID Block: Block Alarm

**Update Alerts** (Generated when a important (restorable) parameter is updated)

By Resource Block: Update Event  
 By Transducer Block: Update Event  
 By AI Block: Update Event  
 By PID Block: Update Event

An alert has the following structure:

**Table 11.4 Alert Object**

Subindex			Parameter Name	Explanation
Analog Alert	Discrete Alert	Update Alert		
1	1	1	Block Index	Index of block from which alert is generated
2	2	2	Alert Key	Alert Key copied from the block
3	3	3	Standard Type	Type of the alert
4	4	4	Mfr Type	Alert Name identified by manufacturer specific DD
5	5	5	Message Type	Reason of alert notification
6	6	6	Priority	Priority of the alarm
7	7	7	Time Stamp	Time when this alert is first detected
8	8		Subcode	Enumerated cause of this alert
9	9		Value	Value of referenced data
10	10		Relative Index	Relative Index of referenced data
		8	Static Revision	Value of static revision (ST_REV) of the block
11	11	9	Unit Index	Unit code of referenced data

### 11.6 Simulation Function

The simulation function simulates the input of a function block and lets it operate as if the data was received from the transducer block. It is possible to conduct testing for the downstream function blocks or alarm processes.

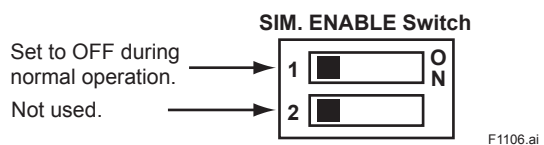
A SIMULATE\_ENABLE jumper switch is mounted on the digitalYEWFLO's amplifier. This is to prevent the accidental operation of this function. When this is switched on, simulation is enabled. (Read Figure 11.4.) To initiate the same action from a remote terminal, if REMOTE LOOP TEST SWITCH is written to SIM\_ENABLE\_MSG (index 1044) parameter of the resource block, the resulting action is the same as is taken when the above switch is on. Note that this parameter value is lost when the power is turned off. In simulation enabled status, an alarm is generated from the resource block, and other device alarms will be masked; for this reason the simulation must be disabled immediately after using this function.

The SIMULATE parameter of AI block consists of the elements listed in Table 11.5 below.

**Table 11.5 SIMULATE Parameter**

Sub-index	Parameters	Description
1	Simulate Status	Sets the data status to be simulated.
2	Simulate Value	Sets the value of the data to be simulated.
3	Transducer Status	Displays the data status from the transducer block. It cannot be changed.
4	Transducer Value	Displays the data value from the transducer block. It cannot be changed.
5	Simulate En/Disable	Controls the simulation function of this block. 1: Disabled (standard) 2: Active(simulation)

When Simulate En/Disable in Table 11.5 above is set to "Active", the applicable function block uses the simulation value set in this parameter instead of the data from the transducer block. This setting can be used for propagation of the status to the trailing blocks, generation of a process alarm, and as an operation test for trailing blocks.



**Figure 11.6 SIMULATE\_ENABLE Switch Position**

Read IM 01F06F00-01EN Chapter 8 for "DEVICE STATUS".

# 12. EXPLOSION PROTECTED TYPE INSTRUMENT FOR FIELDBUS COMMUNICATION TYPE

 **NOTE**

Read Chapter 10 for other Explosion Protected Type of digital YEW FLO Series Vortex Flowmeter.

In this section, further requirements and differences for explosion protected type instrument are described. For explosion protected type instrument, the description in this chapter is prior to other description in this Instruction Manual.

 **WARNING**

- Only trained persons use this instrument in industrial locations.

 **CAUTION**

- Process temperature and ambient temperature on this section are the specifications for explosion protected type. Read IM 01F06A00-01EN Section 13.1 “Standard Specifications” before operating.

## 12.1 ATEX

 **WARNING**

- Only trained persons use this instrument in industrial locations.
- Electrostatic charge may cause an explosion hazard. Avoid any actions that cause the generation of electrostatic charge, such as rubbing with a dry cloth on coating face of product.

■ **Technical Data**

• **Intrinsically Safe Ex ia**

Applicable Standard: EN 60079-0: 2012 +A11: 2013,  
EN 60079-11: 2012,  
EN 60079-27: 2006

Certificate: KEMA 03ATEX1136X  
Type of Protection: Ex ia IIC T4...T1 Ga (Integral Type)  
Ex ia IIC T6...T1 Ga (Remote Type Detector)  
Ex ia IIC T4 Ga (Remote Type Converter)

Group: II

Category: 1 G

Ambient Temperature: -40 to +60°C (Integral Type)  
-50 to +80[+78]°C (Remote Type Detector)  
-40 to +80°C (Remote Type Converter)

(Option /LT below -29°C, [ ] Option /MV at T6)

Electrical Data: Entity Ui = 24 V,  
Ii = 250 mA, Pi = 1.2 W,  
Ci = 3.52 nF, Li = 0 mH  
FISCO(IIC) Ui = 17.5 V,  
Ii = 500 mA, Pi = 5.5 W,  
Ci = 3.52 nF, Li = 0 mH

Connect sensor circuit of DYA and DY-N (/HT)

(Integral Type)

Temperature Class	Process Temperature
T4	≤ +135°C
T3	≤ +200°C
T2	≤ +250°C
T1	≤ +250°C

(Remote Type Detector)

Temperature Class	Process Temperature*
T6	≤ +84/[+78]°C
T5	≤ +100°C
T4	≤ +135°C
T3	≤ +199°C
T2	≤ +299/[+288]°C
T1	≤ +449/[+438]°C

\*: Use /HT option above +250°C, use /LT option below -29 °C, [ ] for /MV option.

**• Intrinsically Safe Ex ic**

Applicable Standard: EN60079-0: 2009/EN60079-0:2012

EN60079-11:2012

Type of Protection: Ex ic IIC T4...T1 Gc (Integral Type)

Ex ic IIC T6...T1 Gc (Remote Type Detector)

Ex ic IIC T5...T4 Gc (Remote Type Converter)

Group: II

Category: 3 G

Enclosure: IP66/67

Overvoltage Category: I

Ambient Temperature:

-40 to +60°C (Integral Type)

-50 to +80 [+79]°C (Remote Type Detector)

(Option /LT below -29°C, [ ] for Option /MV at T6)

-40 to +80°C (Remote Type Converter)

(Integral Type)

Temperature Class	Process Temperature
T4	-40°C to +135°C
T3	-40°C to +199°C
T2	-40°C to +250°C
T1	-40°C to +250°C

(Remote Type Detector)

Temperature Class	Process Temperature
T6	-196°C to +84/[+79]°C
T5	-196°C to +100°C
T4	-196°C to +135°C
T3	-196°C to +199°C
T2	-196°C to +299/[+289]°C
T1	-196°C to +449/[+439]°C

\*: Use /HT option above +250°C, use /LT option below -29°C, [ ] for /MV option.

Electrical data:

Supply and Output Circuit (SUPPLY + and -);

FISCO Field Device

Entity Concept:

Maximum Input Voltage Ui: 32Vdc

Internal Capacitance Ci: 3.52nF

Internal Inductance Li: 0mH

Electrical Connection: ANSI 1/2 NPT female,

ISO M20 X 1.5 female

For the connection of DYA to DY-N :

Maximum cable capacitance: 160nF

Electrical Connection: ANSI 1/2 NPT female, ISO M20 X 1.5 female

**Special conditions for safe use**

1. For process temperatures above 250°C the flow meters of the /HT version must be used.
  2. Because the enclosures of the flow meters and the flow converter are made of aluminium alloy, when used in an potentially explosive atmosphere requiring apparatus of equipment category 1 G, they must be installed so, that even in the event of rare incidents, an ignition source due to impact of friction between the enclosure and iron/steel is excluded.
- Precautions shall be taken to minimize the risk from electrostatic discharge of painted parts.
  - The dielectric strength of at least 500 V a.c. r.m.s. between the intrinsically safe circuits and the enclosure of the flow meter or the converter is limited only by the overvoltage protection.

**■ Installation**



**WARNING**

- All wiring shall comply with local installation requirements and local electrical code.
- Use the suitable heat-resisting cables (over 90°C) for the digital YEFWLO Series Vortex Flowmeter when the ambient temperature exceeds 60°C and/or the process temperature exceeds 200°C.
- For flameproof; Cable glands, adapters and/or blanking elements shall be of Ex "d" for Ex "d" installations. They shall be installed so as to maintain the specified degree of protection (IP Code) of the flowmeter.
- For ATEX intrinsically safe Ex ic; Cable glands, adapter and / or blanking elements shall be of Ex "n", Ex "e", or Ex "d" and shall be installed so as to maintain the specified degree of protection (IP Code) of the equipment.

■ Operation



**WARNING**

- In case of Flameproof, wait 3 min. after power is turned off, before opening the covers.
- Take care not to generate mechanical spark when access to the instrument and peripheral devices in hazardous locations.

■ Maintenance and Repair

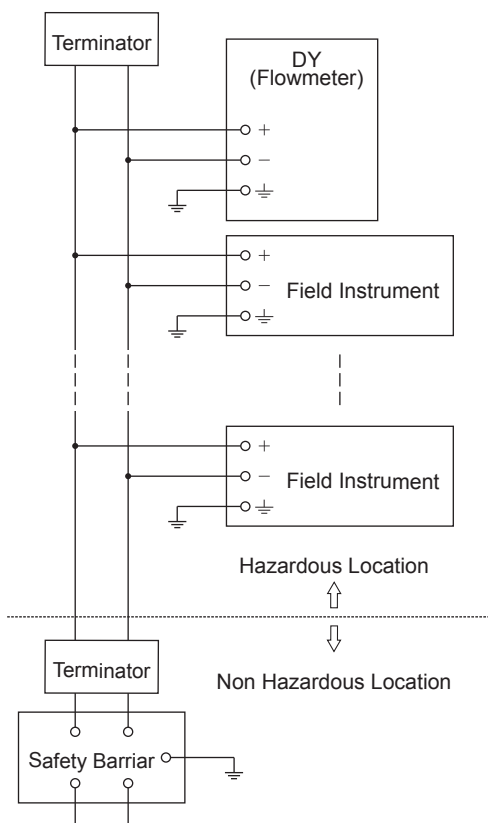


**WARNING**

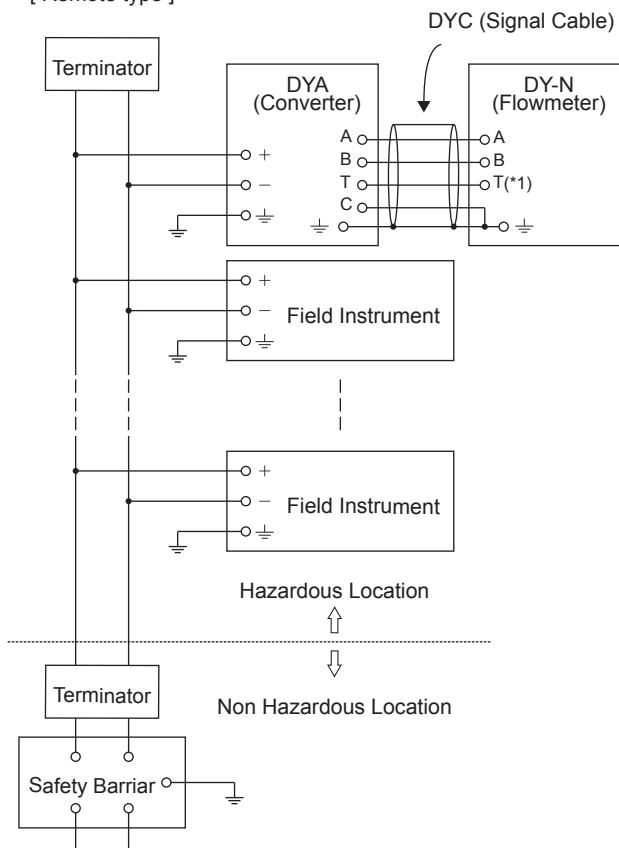
- The instrument modification or parts replacement by other than authorized representative of Yokogawa Electric Corporation is prohibited and will void the certification.

■ Installation Diagram of Intrinsically safe (and Note)

[ Integral type ]



[ Remote type ]



(\*1): Wire for T terminal  
 With temperature sensor type: Installed  
 Without temperature sensor type: Not Installed

Note

- In the rating 1, the output current of the barrier must be limited by a resistor 'Ra' such that  $I_o = U_o / R_a$ .
- In the rating 2, the output of the barrier must be the characteristics of the trapezoid or the rectangle and this transmitter can be connected to Fieldbus equipment which are in according to the FISCO model.
- The terminators may be built-in by a barrier.
- More than one field instrument may be connected to the power supply line.
- The terminator and the safety barrier shall be certified.

F1201.ai

Electrical data

	Ex ia II C		Ex ic II C
	Rating1 (Entity)	Rating2 (FISCO)	Rating (Entity)
Maximum Input Voltage $U_i$	24 Vdc	17.5 Vdc	32 Vdc
Maximum Input Current $I_i$	250 mA	500 mA	—
Maximum Input Power $P_i$	1.2 W	5.5 W	—
Maximum Internal Capacitance $C_i$	3.52 nF	3.52 nF	3.52 nF
Maximum Internal Inductance $L_i$	0 mH	0 mH	0 mH

■ Name Plate

[Integral type, Flameproof]

digitalYEWFL0 VORTEX FLOWMETER		OUTPUT	---	TAG NO.	
MODEL	STYLE	MWP	MPa at 38°C	CE 0344 Ex II 2G	No. KEIRA 11ATEX021X Ex ic IIC T6, T1 Gc -50°C ≤ Ta ≤ +80°C (WITH INDICATOR) PROCESS TEMP. ≤ 200°C, USE THE HEAT-RESISTING CABLE AND CABLE GLAND ≥ 90°C. NOTE: USE /HT VERSION ABOVE 250°C.
SUFFIX		PROCESS TEMP.	°C		
		K-FACTOR			
		RANGE			
		NO.			
SUPPLY	V DC=				
Yokogawa Electric Corporation TOKYO 150-8750 JAPAN YOKOGAWA Made in ◆2		AFTER DE-ENERGIZING DELAY 3 MINUTES BEFORE OPENING. POTENTIAL ELECTROSTATIC CHARGING HAZARD - READ IM 01F06A01-01			

[Remote type detector, Flameproof]

digitalYEWFL0 VORTEX FLOWMETER		MWP	MPa at 38°C	TAG NO.	
MODEL	STYLE	PROCESS TEMP.	°C	CE 0344 Ex II 2G	No. KEIRA 1013221X Ex ic IIC T6, T1 Gc -50°C ≤ Ta ≤ +80°C (WITH INDICATOR) PROCESS TEMP. ≤ 200°C, USE THE HEAT-RESISTING CABLE AND CABLE GLAND ≥ 90°C. NOTE: USE /HT VERSION ABOVE 250°C.
SUFFIX					
		K-FACTOR			
		RANGE			
		NO.			
SUPPLY	V DC=				
Yokogawa Electric Corporation TOKYO 150-8750 JAPAN YOKOGAWA Made in ◆2		AFTER DE-ENERGIZING DELAY 3 MINUTES BEFORE OPENING. POTENTIAL ELECTROSTATIC CHARGING HAZARD - READ IM 01F06A01-01			

[Remote type converter, Flameproof]

digitalYEWFL0 VORTEX FLOW CONVERTER		OUTPUT	---	TAG NO.	
MODEL	STYLE	MWP	MPa at 38°C	CE 0344 Ex II 2G	No. KEIRA 11ATEX021X Ex ic IIC T6, T1 Gc -50°C ≤ Ta ≤ +80°C (WITH INDICATOR)
SUFFIX		PROCESS TEMP.	°C		
		K-FACTOR			
		RANGE			
		NO.			
SUPPLY	V DC=				
Yokogawa Electric Corporation TOKYO 150-8750 JAPAN YOKOGAWA Made in ◆2		AFTER DE-ENERGIZING DELAY 3 MINUTES BEFORE OPENING. POTENTIAL ELECTROSTATIC CHARGING HAZARD - READ IM 01F06A01-01			

[Integral type, Intrinsically safe Ex ia]

digitalYEWFL0 VORTEX FLOWMETER		OUTPUT	---	TAG NO.	
MODEL	STYLE	MWP	MPa at 38°C	CE 0344 Ex II 1 G	No. KEIRA 11ATEX021X Ex ia IIC T6, T1 Gc -50°C ≤ Ta ≤ +80°C Energy: UI 24 V, Ii 250 mA, Pi 1.2 W, Ei 24 V, Ii 250 mA, Pi 1.2 W, Ei 24 V, Ii 250 mA, Pi 1.2 W
SUFFIX		PROCESS TEMP.	°C		
		K-FACTOR			
		RANGE			
		NO.			
SUPPLY	9 to 17.5(24) V DC=				
Yokogawa Electric Corporation TOKYO 150-8750 JAPAN YOKOGAWA Made in ◆2		AFTER DE-ENERGIZING DELAY 3 MINUTES BEFORE OPENING. POTENTIAL ELECTROSTATIC CHARGING HAZARD - READ IM 01F06A01-01			

[Remote type detector, Intrinsically safe Ex ia]

digitalYEWFL0 VORTEX FLOWMETER		MWP	MPa at 38°C	TAG NO.	
MODEL	STYLE	PROCESS TEMP.	°C	CE 0344 Ex II 1 G	No. KEIRA 11ATEX021X Ex ia IIC T6, T1 Gc -50°C ≤ Ta ≤ +80°C
SUFFIX					
		K-FACTOR			
		RANGE			
		NO.			
SUPPLY	V DC=				
Yokogawa Electric Corporation TOKYO 150-8750 JAPAN YOKOGAWA Made in ◆2		AFTER DE-ENERGIZING DELAY 3 MINUTES BEFORE OPENING. POTENTIAL ELECTROSTATIC CHARGING HAZARD - READ IM 01F06A01-01			

[Remote type converter, Intrinsically safe Ex ia]

digitalYEWFL0 VORTEX FLOW CONVERTER		OUTPUT	---	TAG NO.	
MODEL	STYLE	MWP	MPa at 38°C	CE 0344 Ex II 1 G	No. KEIRA 11ATEX021X Ex ia IIC T6, T1 Gc -50°C ≤ Ta ≤ +80°C Energy: UI 24 V, Ii 250 mA, Pi 1.2 W, Ei 24 V, Ii 250 mA, Pi 1.2 W, Ei 24 V, Ii 250 mA, Pi 1.2 W
SUFFIX		PROCESS TEMP.	°C		
		K-FACTOR			
		RANGE			
		NO.			
SUPPLY	9 to 17.5(24) V DC=				
Yokogawa Electric Corporation TOKYO 150-8750 JAPAN YOKOGAWA Made in ◆2		AFTER DE-ENERGIZING DELAY 3 MINUTES BEFORE OPENING. POTENTIAL ELECTROSTATIC CHARGING HAZARD - READ IM 01F06A01-01			

[Integral type, Intrinsically safe Ex ic]

digitalYEWFL0 VORTEX FLOWMETER		OUTPUT	---	TAG NO.	
MODEL	STYLE	MWP	MPa at 38°C	CE II 3 G	ENCLOSURE : IP66/IP67 Ex ic IIC T6, T1 Gc -50°C ≤ Ta ≤ +80°C UL 30V, CI 355V Ii 0.1AH FISCO 1461 device NOTE: USE /HT VERSION ABOVE 250°C.
SUFFIX		PROCESS TEMP.	°C		
		K-FACTOR			
		RANGE			
		NO.			
SUPPLY	9-32V DC=				
Yokogawa Electric Corporation TOKYO 150-8750 JAPAN YOKOGAWA Made in ◆2		AFTER DE-ENERGIZING DELAY 3 MINUTES BEFORE OPENING. POTENTIAL ELECTROSTATIC CHARGING HAZARD - READ IM 01F06A01-01 WHEN THE PROCESS TEMP. ≥ 200°C, USE THE HEAT-RESISTING CABLE AND CABLE GLAND ≥ 90°C.			

[Remote type detector, Intrinsically safe Ex ic]

digitalYEWFL0 VORTEX FLOWMETER		MWP	MPa at 38°C	TAG NO.	
MODEL	STYLE	PROCESS TEMP.	°C	CE II 3 G	ENCLOSURE : IP66/IP67 Ex ic IIC T6, T1 Gc -50°C ≤ Ta ≤ +80°C UL 30V, CI 355V Ii 0.1AH FISCO 1461 device NOTE: USE /HT VERSION ABOVE 250°C.
SUFFIX					
		K-FACTOR			
		RANGE			
		NO.			
SUPPLY	V DC=				
Yokogawa Electric Corporation TOKYO 150-8750 JAPAN YOKOGAWA Made in ◆2		AFTER DE-ENERGIZING DELAY 3 MINUTES BEFORE OPENING. POTENTIAL ELECTROSTATIC CHARGING HAZARD - READ IM 01F06A01-01			

[Remote type converter, Intrinsically safe Ex ic]

digitalYEWFL0 VORTEX FLOW CONVERTER		OUTPUT	---	TAG NO.	
MODEL	STYLE	MWP	MPa at 38°C	CE II 3 G	ENCLOSURE : IP66/IP67 Ex ic IIC T6, T1 Gc -50°C ≤ Ta ≤ +80°C UL 30V, CI 355V Ii 0.1AH FISCO 1461 device
SUFFIX		PROCESS TEMP.	°C		
		K-FACTOR			
		RANGE			
		NO.			
SUPPLY	9-32V DC=				
Yokogawa Electric Corporation TOKYO 150-8750 JAPAN YOKOGAWA Made in ◆2		AFTER DE-ENERGIZING DELAY 3 MINUTES BEFORE OPENING. POTENTIAL ELECTROSTATIC CHARGING HAZARD - READ IM 01F06A01-01 WHEN THE PROCESS TEMP. ≥ 200°C, USE THE HEAT-RESISTING CABLE AND CABLE GLAND ≥ 90°C.			

MODEL: Specified model code

SUFFIX : Specified suffix code

STYLE: Style code

SUPPLY : Supply voltage

OUTPUT : Output signal

MWP : Maximum working pressure

PROCESS TEMP.: Process temperature

K-FACTOR : Device-specific factor

RANGE: Specified range

NO.: Upper column: Manufacturing serial number \*1

Lower column: The year and month of protection

TAG NO. : Specified TAG No.

CE: CE marking

0344: The identification number of the notified body

I1G: Group I Category 1 Gas atmosphere

I2G: Group II Category 2 Gas atmosphere

I3G: Group II Category 3 Gas atmosphere

\*1) The first digit in the final three numbers of the serial number appearing after "NO." on the name plate indicates the year of production. The following is an example of a serial number for a product that was produced in 2015:  
NO. S5K965926 535

↑Produced in 2015

\*2) The product-producing country



## 12.2 FM

### ■ Technical Data

#### • Intrinsically Safe

Applicable Standard: Class 3600: 2011,  
Class 3610: 2010,  
Class 3611: 2004,  
Class 3810: 2005,  
NEMA 250: 1991,  
ANSI/ISA 60079-0: 2013,  
ANSI/ISA 60079-11: 2014,  
ANSI/ISA 60079-27: 2006

Type of Protection : Intrinsically Safe for Class I,  
II, III, DIV.1, Groups A, B, C, D, E, F and G,  
T4, and Class I, Zone 0, AEx ia IIB/IIC T4,  
Entity, FISCO  
Nonincendive for Class I, II, Div.2, Groups  
A, B, C, D, F and G, Class III, DIV.1, Class I,  
Zone 2, Group IIC, FNICO

Ambient Temperature :  
-40 to +60°C (Integral Type and Vortex Flow  
Converter)  
-40 to +80°C (Remote Type Detector)

Indoors and Outdoors : Type 4X

Electrical Parameters : Intrinsically Safe  
[Entity] Vmax=24 V, Imax=250 mA,  
Pi=1.2 W, Ci=3.52 nF, Li=0 mH  
[FISCO (IIC)] Vmax=17.5 V, Imax=380 mA,  
Pi=5.32 W, Ci=3.52 nF, Li=0 mH  
[FISCO (IIB)] Vmax=17.5 V, Imax=460 mA,  
Pi=5.32 W, Ci=3.52 nF, Li=0 mH

Nonincendive  
Vmax=32 V, Ci=3.52 nF, Li=0 mH

Electrical Connection : ANSI 1/2NPT female

### ■ Wiring

#### • Intrinsically Safe



### NOTE

- If you are using a hand-held terminal in the hazardous area, read the Control Drawing or Instruction Manual of handheld terminal.

### ■ Operation



### WARNING

- Take care not to generate mechanical spark when access to the instrument and peripheral devices in hazardous locations.

### ■ Maintenance and Repair



### WARNING

- The instrument modification or part replacements by other than authorized representative of Yokogawa Electric Corporation is prohibited and will void the approval of FM Approvals.

■ Installation Diagram

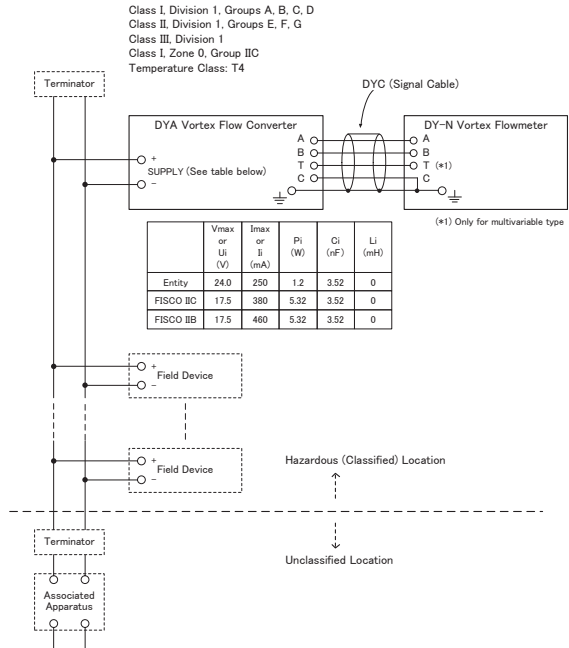
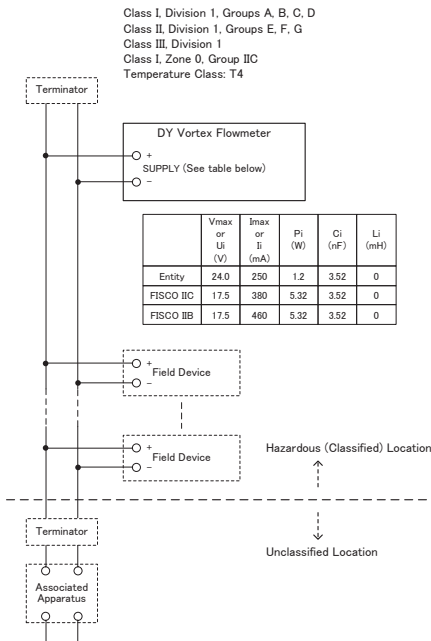
Intrinsically Safe (and WARNING)

Model: DY Series Date: April 18, 2014 Model: DY Series Date: April 18, 2014

Control Drawing

Intrinsically Safe Installation (Remote Type)

Intrinsically Safe Installation (Integral Type)



Rev. Doc. No.: IFM021-A20 P.1

Rev. Doc. No.: IFM021-A20 P.2

Yokogawa Electric Corporation

Yokogawa Electric Corporation

Model: DY Series Date: April 18, 2014

Notes:

- This drawing replaces the former control drawing IFM021-A12.
- No revision to this drawing without prior approval of FM.
- Installation must be in accordance with the National Electric Code (NFPA70), ANSI/ISA RP12.06.01 and relevant local codes.
- The associated apparatus must be FM approved.
- Control equipment connected to the associated apparatus must not use or generate more than 250 V a.c. r.m.s or d.c.
- In case of entity-concept installations, the associated apparatus must be a linear source which meets the following conditions.
  - $V_{oc} \text{ (or } U_o) \leq V_{max} \text{ (or } U_i)$
  - $I_{sc} \text{ (or } I_o) \leq I_{max} \text{ (or } I_i)$
  - $P_o \leq P_{max} \text{ (or } P_i)$
  - $C_a \text{ (or } C_o) \leq C_i + C_{cable}$
  - $L_a \text{ (or } L_o) \leq L_i + L_{cable}$
- FISCO installation must be in accordance with ANSI/ISA-60079-25 or ANSI/ISA-60079-27.
- The control drawing of the associated apparatus must be followed when installing the flow meter or flow converter.
- The terminator(s) must be FM approved.
- The dielectric strength of at least 500 V a.c. r.m.s. between the intrinsically safe circuits and the enclosure of the flow meter or the converter is limited only by the overvoltage protection.
- Dust-tight conduit seals must be used when installed in Class II or Class III environments.
- Precautions shall be taken to minimize the risk from electrostatic discharge of painted parts of the enclosure.
- WARNING – POTENTIAL ELECTROSTATIC CHARGING HAZARD – SEE USER'S MANUAL
- WARNING – IN THE CASE WHERE THE ENCLOSURE OF THE VORTEX FLOW METER AND CONVERTER ARE MADE OF ALUMINUM, IF IT IS MOUNTED IN ZONE 0, IT MUST BE INSTALLED SUCH, THAT EVEN IN THE EVENT OF RARE INCIDENTS, IGNITION SOURCES DUE TO IMPACT AND FRICTION SPARKS ARE EXCLUDED
- WARNING – SUBSTITUTION OF COMPONENTS MAY IMPAIR INTRINSIC SAFETY

Rev. Doc. No.: IFM021-A20 P.3

Yokogawa Electric Corporation

EXPLOSION PROTECTED TYPE INSTRUMENT FOR FIELDBUS COMMUNICATION TYPE

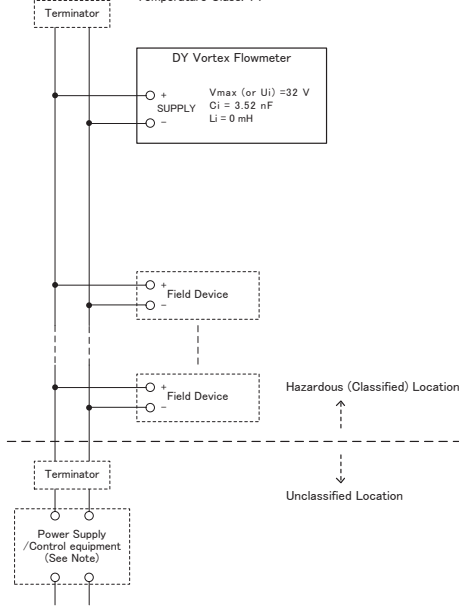
Model: DY Series Date: April 18, 2014

Model: DY Series Date: April 18, 2014

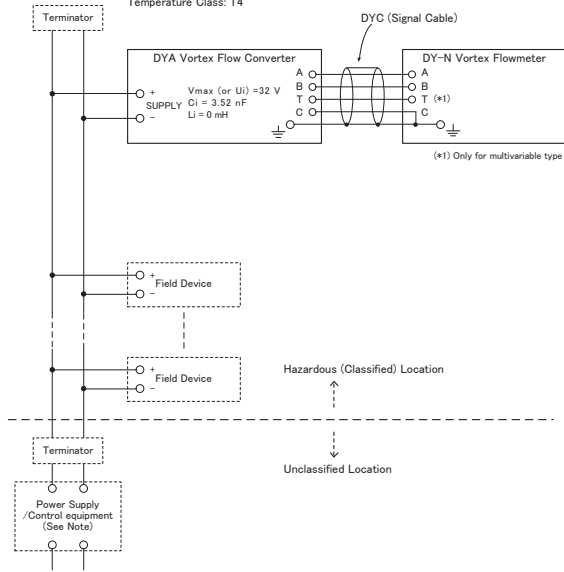
Division 2 Installation (Integral Type)

Division 2 Installation (Remote Type)

Class I, Division 2, Groups A, B, C, D  
 Class II, Division 2, Groups F, G  
 Class III, Division 1  
 Class I, Zone 2, Group IIC  
 Temperature Class: T4



Class I, Division 2, Groups A, B, C, D  
 Class II, Division 2, Groups F, G  
 Class III, Division 1  
 Class I, Zone 2, Group IIC  
 Temperature Class: T4



Rev. Doc. No.: IFM021-A20 P.4

Rev. Doc. No.: IFM021-A20 P.5

Yokogawa Electric Corporation

Yokogawa Electric Corporation

Model: DY Series Date: April 18, 2014

Notes:

- This drawing replaces the former control drawing IFM021-A12.
- No revision to this drawing without prior approval of FM.
- Installation must be in accordance with the National Electric Code (NFPA70), ANSI/ISA RP12.06.01 and relevant local codes.
- In case Nonincendive Field Wiring Concept is used for the interconnection, FM approved Associated Nonincendive Field Wiring Apparatus, which meets the following conditions, must be used as the power supply / control equipment.
  - $V_{oc} \text{ (or } U_o) \leq V_{max} \text{ (or } U_i)$
  - $C_a \text{ (or } C_o) \leq C_i + C_{cable}$
  - $L_a \text{ (or } L_o) \leq L_i + L_{cable}$
- FNICO installation must be in accordance with ANSI/ISA-60079-27. ANSI/ISA-60079-25 allows the use of FNICO field device in "ic PISCO" system.
- The control drawing of the associated apparatus must be followed when installing the flow meter or flow converter.
- The terminator(s) must be FM approved.
- Dust-tight conduit seals must be used when installed in Class II or Class III environments.
- WARNING – EXPLOSION HAZARD. FOR INSTALLATION OTHER THAN NONINCENDIVE FIELD WIRING, DO NOT DISCONNECT EQUIPMENT WHEN A FLAMMABLE OR COMBUSTIBLE ATMOSPHERE IS PRESENT
- WARNING – SUBSTITUTION OF COMPONENTS MAY IMPAIR SUITABILITY FOR DIVISION 2

Rev. Doc. No.: IFM021-A20 P.6

Yokogawa Electric Corporation

### 12.3 IECEx

■ **Technical Data**

• **Intrinsically Safe**

Applicable Standard: IEC 60079-0: 2011, IEC 60079-11: 2011

Certificate: IECEx DEK 15.0012X

Type of Protection:

- Ex ia IIC T4...T1 Ga (Integral Type)
- Ex ia IIC T6...T1 Ga (Remote Type Detector)
- Ex ia IIC T4 Ga (Remote Type Converter)

Ambient Temperature:

- 40 to +60°C (Integral Type)
- 50 to +80[+78]°C (Remote Type Detector)
- 40 to +80°C (Remote Type Converter)
- (Option /LT below -29°C, [] for Option /MV at T6)

Connect sensor circuit of DYA and DY-N (/HT)

Electrical Data:

- Entity  $U_i = 24\text{ V}$ ,  $I_i = 250\text{ mA}$ ,  $P_i = 1.2\text{ W}$ ,  $C_i = 3.52\text{ nF}$ ,  $L_i = 0\text{ mH}$
- FISCO (IIC)  $U_i = 17.5\text{ V}$ ,  $I_i = 500\text{ mA}$ ,  $P_i = 5.5\text{ W}$ ,  $C_i = 3.52\text{ nF}$ ,  $L_i = 0\text{ mH}$

Temperature Class:

(Integral Type)

Temperature Class	Process Temperature
T4	$\leq +135^\circ\text{C}$
T3	$\leq +200^\circ\text{C}$
T2	$\leq +250^\circ\text{C}$
T1	$\leq +250^\circ\text{C}$

(Remote Type Detector)

Temperature Class	Process Temperature*
T6	$\leq +84[+78]^\circ\text{C}$
T5	$\leq +100^\circ\text{C}$
T4	$\leq +135^\circ\text{C}$
T3	$\leq +199^\circ\text{C}$
T2	$\leq +299[+288]^\circ\text{C}$
T1	$\leq +449[+438]^\circ\text{C}$

\*: Use /HT option above +250 °C, use /LT option below -29 °C, [] for /MV option.

Electrical Connection: ANSI 1/2 NPT female, ISO M20 X 1.5 female

**Special conditions for safe use**

- For process temperatures above +250°C the flow meters of the /HT version must be used.
- Precautions shall be taken to minimize the risk from electrostatic discharge of painted parts.
- When the enclosure of the flow meter or the flow converter are made of aluminum, if it is mounted in an area where the use of EPL Ga equipment is required, it must be installed such that, even in the event of rare incidents, ignition sources due to impact and friction sparks are excluded.
- The dielectric strength of at least 500 V a.c. r.m.s. between the intrinsically safe circuits and the enclosure of the flow meter or the converter is limited only by the overvoltage protection.

■ **Installation**

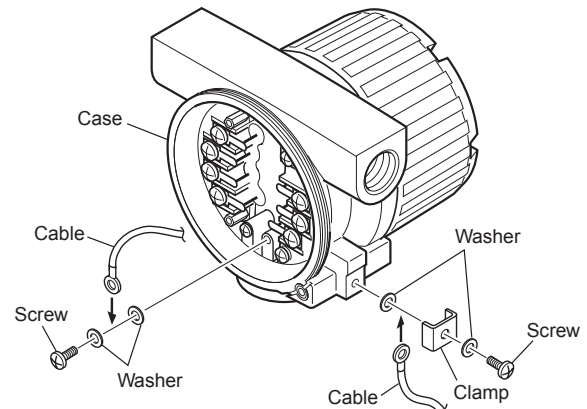


**WARNING**

- All wiring shall comply with local installation requirements and local electrical code.
- Use the suitable heat-resisting cables (over 90°C) for the digital YEW FLO Series Vortex Flowmeter when the ambient temperature exceeds 60°C and/or the process temperature exceeds 200°C.
- The cable entry devices shall be certified in type of protection flame proof enclosure “d” and suitable for the conditions of use and correctly installed.
- Unused apertures shall be closed with certified blanking elements in type of protection flame proof enclosure “d”.

The grounding terminals are located on the inside and outside of the terminal area.

Connect the cable to grounding terminal in accordance with wiring procedure (1) or (2).



(1) Internal grounding terminal (2) External grounding terminal

**Figure 12.1 Wiring Procedure for Grounding Terminals**

■ Operation

**WARNING**

- In case of Flameproof, wait 3 min. after power is turned off, before opening the covers.
- Take care not to generate mechanical spark when access to the instrument and peripheral devices in hazardous locations.

■ Maintenance and Repair

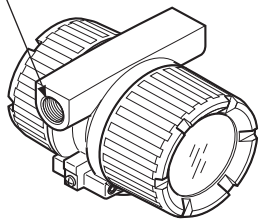
**WARNING**

- The instrument modification or parts replacement by other than authorized representative of Yokogawa Electric Corporation is prohibited and will void the certification.

■ Electrical Connection

The type of electrical connection is stamped near the electrical connection port according to the following codes.

Screw size	Marking
ISO M20 X 1.5 female	⚠ M
ANSI 1/2-14NPT female	⚠ N



F1203.ai

■ Name Plate

[Integral type, Flameproof]

digitalYEWFLO VORTEX FLOWMETER		OUTPUT	---	TAG NO.	
MODEL	STYLE	MWP	MPa at 38°C	No. ICEX DEK 110077X	
SUFFIX		PROCESS TEMP.	°C	Ex d IIC T8-T1 Gb	
		K-FACTOR		Tamb: -40 TO +60°C / -30 TO +60°C (WITH INDICATOR)	
		RANGE		TEMP CLASS: T8 T5 T4 T3 T2 T1	
		NO.		PROCESS TEMP: -40 to 80 100 135 200 300 450°C	
SUPPLY	V DC=				
Yokogawa Electric Corporation TOKYO 180-8750 JAPAN YOKOGAWA Made in		⚠ AFTER DE-ENERGIZING, DELAY 3 MINUTES BEFORE OPENING. THE PROCESS TEMP. 320°C. USE THE HEAT-RESISTING CABLE AND CABLE GLAND ≤ 30°C. POTENTIAL ELECTROSTATIC CHARGING HAZARD - READ IM 01F06A01-01		UH	

[Remote type detector, Flameproof]

digitalYEWFLO VORTEX FLOWMETER		OUTPUT	---	TAG NO.	
MODEL	STYLE	MWP	MPa at 38°C	No. ICEX DEK 110077X	
SUFFIX		PROCESS TEMP.	°C	Ex d IIC T8-T1 Gb	
		K-FACTOR		Tamb: -40 TO +60°C	
		RANGE		TEMP CLASS: T8 T5 T4 T3 T2 T1	
		NO.		PROCESS TEMP: -40 to 80 100 135 200 300 450°C	
SUPPLY	V DC=				
Yokogawa Electric Corporation TOKYO 180-8750 JAPAN YOKOGAWA Made in		⚠ AFTER DE-ENERGIZING, DELAY 3 MINUTES BEFORE OPENING. THE PROCESS TEMP. 320°C. USE THE HEAT-RESISTING CABLE AND CABLE GLAND ≤ 30°C. POTENTIAL ELECTROSTATIC CHARGING HAZARD - READ IM 01F06A01-01		WH	

[Remote type converter, Flameproof]

digitalYEWFLO VORTEX FLOW CONVERTER		OUTPUT	---	TAG NO.	
MODEL	STYLE	MWP	MPa at 38°C	No. ICEX DEK 110077X	
SUFFIX		PROCESS TEMP.	°C	Ex d IIC T8-T1 Gb	
		K-FACTOR		Tamb: -40 TO +60°C	
		RANGE		TEMP CLASS: T8 T5 T4 T3 T2 T1	
		NO.		PROCESS TEMP: -40 to 80 100 135 200 300 450°C	
SUPPLY	V DC=				
Yokogawa Electric Corporation TOKYO 180-8750 JAPAN YOKOGAWA Made in		⚠ AFTER DE-ENERGIZING, DELAY 3 MINUTES BEFORE OPENING. POTENTIAL ELECTROSTATIC CHARGING HAZARD - READ IM 01F06A01-01		YH	

[Integral type, Intrinsically safe]

digitalYEWFLO VORTEX FLOWMETER		OUTPUT	---	TAG NO.	
MODEL	STYLE	MWP	MPa at 38°C	No. ICEX DEK 15.0012X	
SUFFIX		PROCESS TEMP.	°C	Ex d IIC T8-T1 Gb	
		K-FACTOR		Tamb: -40 TO +60°C	
		RANGE		Entry: IIC T8-T1 Gb	
		NO.		Ex d IIC T8-T1 Gb -50 °C ≤ Ta ≤ 80 °C CC: 3.620 mPa, Pi: 1.2 W	
SUPPLY	9 to 17.5(24) V DC=				
Yokogawa Electric Corporation TOKYO 180-8750 JAPAN YOKOGAWA Made in		⚠ POTENTIAL ELECTROSTATIC CHARGING HAZARD - READ IM 01F06A01-01		VH	

[Remote type detector, Intrinsically safe]

digitalYEWFLO VORTEX FLOWMETER		OUTPUT	---	TAG NO.	
MODEL	STYLE	MWP	MPa at 38°C	No. ICEX DEK 15.0012X	
SUFFIX		PROCESS TEMP.	°C	Ex d IIC T8-T1 Gb	
		K-FACTOR		Tamb: -40 TO +60°C	
		RANGE		Ex d IIC T8-T1 Gb -50 °C ≤ Ta ≤ 80 °C	
		NO.			
Yokogawa Electric Corporation TOKYO 180-8750 JAPAN YOKOGAWA Made in		⚠ POTENTIAL ELECTROSTATIC CHARGING HAZARD - READ IM 01F06A01-01		XH	

[Remote type converter, Intrinsically safe]

digitalYEWFLO VORTEX FLOW CONVERTER		OUTPUT	---	TAG NO.	
MODEL	STYLE	MWP	MPa at 38°C	No. ICEX DEK 15.0012X	
SUFFIX		PROCESS TEMP.	°C	Ex d IIC T8-T1 Gb	
		K-FACTOR		Tamb: -40 TO +60°C	
		RANGE		Entry: IIC T8-T1 Gb	
		NO.		Ex d IIC T8-T1 Gb -50 °C ≤ Ta ≤ 80 °C CC: 3.620 mPa, Pi: 1.2 W	
SUPPLY	9 to 17.5(24) V DC=				
Yokogawa Electric Corporation TOKYO 180-8750 JAPAN YOKOGAWA Made in		⚠ POTENTIAL ELECTROSTATIC CHARGING HAZARD - READ IM 01F06A01-01		ZH	

MODEL: Specified model code

SUFFIX: Specified suffix code

STYLE: Style code

SUPPLY: Supply voltage

OUTPUT: Output signal

MWP: Maximum working pressure

PROCESS TEMP.: Process temperature

K-FACTOR: Device-specific factor

RANGE: Specified range

NO.: Manufacturing serial number

TAG NO.: Specified TAG No.

\*1 The product - producing country

# 13. PED (PRESSURE EQUIPMENT DIRECTIVE)

This chapter is described further requirements and notices concerning the PED (Pressure Equipment Directive). The description in this chapter is prior to other description in this User's Manual.

## (1) Technical Data

### Pressure Equipment Directive:

Type of equipment: piping

Type of fluid: liquid and gas

Group of fluid: 1 and 2

Module: H

MODEL	DN(mm)*	PS(MPa)*	PS-DN(MPa·mm)	CATEGORY**
DY015	15	42	630	Article 3,*** Paragraph 3 (SEP)
DY025	25	42	1050	Article 3,*** Paragraph 3 (SEP)
DY040	40	42	1680	II****
DY050	50	42	2100	II****
DY080	80	42	3360	II****
DY100	100	42	4200	II****
DY150	150	42	6300	III
DY200	200	42	8400	III
DY250	250	42	10500	III
DY300	300	42	12600	III
DY400	400	25	10000	III

\* PS: Maximum allowable pressure for Flow tube, DN: Nominal size

\*\* Referred to Table 6 covered by ANNEX II of EC Directive on Pressure Equipment Directive 97/23/EC

\*\*\* Sound Engineering Practice (SEP)

\*\*\*\* MODELS classified in CATEGORY II shall not be used for unstable gases of Group 1.

CE Marking is indicated on the name plate of non-explosion protected type and ATEX explosion protected type.

## (2) Installation



### WARNING

- Please tighten the bolts for piping joint according to the appropriate torque values.
- Please take measure to protect the flowmeters from forces caused by vibration through piping.

## (3) Operation



### WARNING

- The temperature and pressure of fluid should be applied under the normal operating condition.
- The ambient temperature should be applied under the normal operating condition.
- Please pay attention to prevent the excessive pressure like water hammer, etc. When water hammer is to be occurred, please take measures to prevent the pressure from exceeding PS (maximum allowable pressure) by setting the safety valve, etc. at the system and the like.
- When external fire is to be occurred, please take safety measures at the device or system not to influence the flowmeters.
- Please pay attention not to abrade the metal pipe, when using the fluid to abrade the metal pipe such as slurry and sand are contained.

# INSTALLATION AND OPERATING PRECAUTIONS FOR TIIS FLAMEPROOF EQUIPMENT

## Apparatus Certified Under Technical Criteria (IEC-compatible Standards)

### 1. General

The following describes precautions on electrical apparatus of flameproof construction (hereinafter referred to as flameproof apparatus) in explosion-protected apparatus.

Following the Labour Safety and Health Laws of Japan, flameproof apparatus is subjected to type tests to meet either the technical criteria for explosionproof electrical machinery and equipment (standards notification no. 556 from the Japanese Ministry of Labour) (hereinafter referred to as technical criteria), in conformity with the IEC Standards, or the "Recommended Practice for Explosion-Protected Electrical Installations in General Industries," published in 1979. These certified apparatus can be used in hazardous locations where explosive or inflammable gases or vapours may be present.

Certified apparatus includes a certification label and an equipment nameplate with the specifications necessary for explosion requirements as well as precautions on explosion protection. Please confirm these precautionary items and use them to meet specification requirements.

For electrical wiring and maintenance servicing, please read "Internal Wiring Rules" in the Electrical Installation Technical Standards as well as "USER'S GUIDELINES for Electrical Installations for Explosive Gas Atmospheres in General Industry," published in 1994.

To meet flameproof requirements, equipment that can be termed "flameproof" must:

- (1) Be certified by a Japanese public authority in accordance with the Labour Safety and Health Laws of Japan and have a certification label in an appropriate location on its case, and
- (2) Be used in compliance with the specifications marked on its certification label, equipment name plate and precautionary information furnished.

### 2. Electrical Apparatus of Flameproof Type of Explosion-Protected Construction

Electrical apparatus which is of flameproof construction is subjected to a type test and certified by the Japanese Ministry of Labour aiming at preventing explosion caused by electrical apparatus in a factory or any location where inflammable gases or vapours may be present. The flameproof construction is of completely enclosed type and its enclosure shall endure explosive pressures in cases where explosive gases or vapours entering the enclosure cause explosion. In addition, the enclosure construction shall be such that flame caused by explosion does not ignite gases or vapours outside the enclosure.

In this manual, the word "flameproof" is applied to the flameproof equipment combined with the types of protection "e", "o", "i", and "d" as well as flameproof equipment.

### 3. Terminology

#### (1) Enclosure

An outer shell of an electrical apparatus, which encloses live parts and thus is needed to configure explosion-protected construction.

#### (2) Shroud

A component part which is so designed that the fastening of joint surfaces cannot be loosened unless a special tool is used.

#### (3) Enclosure internal volume

This is indicated by:— the total internal volume of the flameproof enclosure minus the volume of the internal components essential to equipment functions.

#### (4) Path length of joint surface

On a joint surface, the length of the shortest path through which flame flows from the inside to outside of the flameproof enclosure. This definition cannot be applied to threaded joints.

### (5) Gaps between joint surfaces

The physical distance between two mating surfaces, or differences in diameters if the mating surfaces are cylindrical.

Note: The permissible sizes of gaps between joint surfaces, the path length of a joint surface and the number of joint threads are determined by such factors as the enclosure's internal volume, joint and mating surface construction, and the explosion classification of the specified gases and vapours.

## 4. Installation of Flameproof Apparatus

### (1) Installation Area

Flameproof apparatus may be installed, in accordance with applicable gases, in a hazardous area in Zone 1 or 2, where the specified gases are present. Those apparatus shall not be installed in a hazardous area in Zone 0.

Note: Hazardous areas are classified in zones based upon the frequency of the appearance and the duration of an explosive gas atmosphere as follows:  
Zone 0: An area in which an explosive gas atmosphere is present continuously or is present for long periods.  
Zone 1: An area in which an explosive gas atmosphere is likely to occur in normal operation.  
Zone 2: An area in which an explosive gas atmosphere is not likely to occur in normal operation and if it does occur it will exist for a short period only.

### (2) Environmental Conditions

The standard environmental condition for the installation of flameproof apparatus is limited to an ambient temperature range from  $-20^{\circ}\text{C}$  to  $+40^{\circ}\text{C}$  (for products certified under Technical Criteria). However, some field-mounted instruments may be certified at an ambient temperature up to  $+60^{\circ}\text{C}$  as indicated on the instrument name plates. If the flameproof apparatus are exposed to direct sunshine or radiant heat from plant facilities, appropriate thermal protection measures shall be taken.

## 5. External Wiring for Flameproof Apparatus

Flameproof apparatus require cable wiring for their electrical connections. For cable wiring, cable glands (cable entry devices for flameproof type) to wiring connections shall be attached. All non-live metal parts such as the enclosure shall be securely grounded. For details, read the "USER'S GUIDELINES for Electrical Installations for Explosive Gas Atmospheres in General Industry," published in 1994.

### (1) Cable Wiring

- For cable wiring, cable glands (cable entry devices for flameproof type) specified or supplied with the apparatus shall be directly attached to the wiring connections to complete sealing of the apparatus.
- Screws that connect cable glands to the apparatus are those for G-type parallel pipe threads (JIS B 0202) with no sealing property. To protect the apparatus from corrosive gases or moisture, apply nonhardening sealant such as liquid gaskets to those threads for waterproofing.
- Specific cables shall be used as recommended by the "USER'S GUIDELINES for Electrical Installations for Explosive Gas Atmospheres in General Industry," published in 1994.
- In necessary, appropriate protective pipes (conduit or flexible pipes), ducts or trays shall be used for preventing the cable run (outside the cable glands) from damage.
- To prevent explosive atmosphere from being propagated from Zone 1 or 2 hazardous location to any different location or non-hazardous location through the protective pipe or duct, apply sealing of the protective pipes in the vicinity of individual boundaries, or fill the ducts with sand appropriately.
- When branch connections of cables is made, a flameproof or increased-safety connection box shall be used. In this case, flameproof or increased-safety cable glands meeting the type of connection box must be used for cable connections to the box.



## 6. Maintenance of Flameproof Apparatus

To maintain the flameproof apparatus, do the following. (For details, read Chapter 10 “MAINTENANCE OF EXPLOSION-PROTECTED ELECTRICAL INSTALLATION” in the USER’S GUIDELINES for Electrical Installations for Explosive Gas Atmospheres in General Industry.)

### (1) Maintenance servicing with the power on.

Flameproof apparatus shall not be maintenance-serviced with its power turned on. However, in cases where maintenance servicing is to be conducted with the power turned on, with the equipment cover removed, always use a gas detector to check that there is no explosive gas in that location. If it cannot be checked whether an explosive gas is present or not, maintenance servicing shall be limited to the following two items:

- (a) Visual inspection  
Visually inspect the flameproof apparatus, metal conduits, and cables for damage or corrosion, and other mechanical and structural defects.
- (b) Zero and span adjustments  
These adjustments should be made only to the extent that they can be conducted from the outside without opening the equipment cover. In doing this, great care must be taken not to cause mechanical sparks with tools.

### (2) Repair

If the flameproof apparatus requires repair, turn off the power and transport it to a safety (non-hazardous) location. Observe the following points before attempting to repair the apparatus.

- (a) Make only such electrical and mechanical repairs as will restore the apparatus to its original condition. For the flameproof apparatus, the gaps and path lengths of joints and mating surfaces, and mechanical strength of enclosures are critical factors in explosion protection. Exercise great care not to damage the joints or shock the enclosure.
- (b) If any damage occurs in threads, joints or mating surfaces, inspection windows, connections between the sensor and terminal box, shrouds or clamps, or external wiring connections which are essential in flameproofness, contact Yokogawa Electric Corporation.



## CAUTION

Do not attempt to re-process threaded connections or refinish joints or mating surfaces.

- (c) Unless otherwise specified, the electrical circuitry and internal mechanisms may be repaired by component replacement, as this will not directly affect the requirements for flameproof apparatus (however, bear in mind that the apparatus must always be restored to its original condition). If you attempt to repair the flameproof apparatus, company-specified components shall be used.
- (d) Before starting to service the apparatus, be sure to check all parts necessary for retaining the requirements for flameproof apparatus. For this, check that all screws, bolts, nuts, and threaded connections have properly been tightened.

### (3) Prohibition of specification changes and modifications

Do not attempt to change specifications or make modifications involving addition of or changes in external wiring connections.

## 7. Selection of Cable Entry Devices for Flameproof Type



## IMPORTANT

The cable glands (cable entry devices for flameproof type) conforming to IEC Standards are certified in combination with the flameproof apparatus. So, Yokogawa-specified cable entry devices for flameproof type shall be used to meet this demand.

### References:

- (1) Type Certificate Guide for Explosion-Protected Construction Electrical Machinery and Equipment (relating to Technical Standards Conforming to International Standards), issued by the Technical Institution of Industrial Safety, Japan
- (2) USER’S GUIDELINES for Electrical Installations for Explosive Gas Atmospheres in General Industry (1994), issued by the Japanese Ministry of Labour, the Research Institute of Industrial Safet

---

# Revision Information

- Title: digitalYEWFLO Series Vortex Flowmeter Installation Manual
- Manual No.: IM 01F06A01-01EN

<b>Edition</b>	<b>Date</b>	<b>Page</b>	<b>Revised Item</b>
1st	Mar. 2015	—	New publication
2nd	Nov. 2015	Front cover 3 5 7 10 39-53 59-70 71	Change the Document No./Title Revise web page address Add (7) (8) (9) Revise Figure 2.1 (a) and 2.1 (b) Revise "Pressure and Temperature Taps" Revision of Chapter 10 Revision of Chapter 12 Revise PED