

General Specifications

YFGW510
Field Wireless Access Point



GS 01W02E01-01EN

■ GENERAL

This General Specification(GS) describes the hardware specifications for Field Wireless Access Point and specifications of attached software. This product is based on wireless communications standard ISA100.11a for industrial automation of International Society of Automation (ISA). This product has backbone router function based on ISA100.11a, and combining this with Field Wireless Management Station (YFGW410) and/or Field Wireless Media Converter (YFGW610) composes the field wireless system.

For outline of a field wireless system, and details of each product, see related product General Specifications.



■ FEATURES

●High-performance, compact industrial wireless access point

This product is an industrial wireless access point, compact and lightweight and supporting multiple wireless standards. Enabling you to build a robust field wireless network, the access point provides reliable communication.

●Duocast (ISA100.11a Standard)

This product supports the “Duocast” function of ISA100.11a standard. Enabling simultaneous communication with two YFGW510s, thereby creating a redundant communication path, increasing the reliability of the field wireless network.

●Wireless LAN (IEEE802.11a/b/g)

This product has a dual band wireless LAN communication Function (2.4 GHz and 5 GHz) in a field wireless backbone. The wireless LAN in field wireless backbone enables a design flexible to the field wireless network of a wide area.

■ HARDWARE SPECIFICATIONS

■ Communication Interface

Item		Field Network Specifications	Field Wireless Backbone Specifications *1		
Communication Interface	Standard	IEEE802.15.4	IEEE802.11a/b/g *2	100BASE-TX	100BASE-FX
	Frequency	2400–2483.5 MHz	b/g: 2400-2483.5 MHz a: 5150-5850 MHz	–	
	Raw data rate	250 kbps	1-54 Mbps	100 Mbps	100 Mbps
	Radio Security	AES128 bit	WPA2-PSK	–	
	RF Transmitter Power	Max 12 dBm *3	Max 18 dBm *3	–	
	Connector	N type	N type	RJ-45	SC connector [single pole × 2] *4
	Cable Type	coaxial	coaxial	Category 5	Multimode fiber (50/125 μm or 62.5/125 μm)
	Antenna	+2 dBi	–	–	
	Remote Antenna	+2 dBi, +6 dBi, +9 dBi	+2 dBi, +6 dBi, +9 dBi	–	
	Maximum length	500 m *5	b/g: 500 m *5 a: 200 m *5	100 m	2000 m
	Port	1 port	Max 2 port	1 port	1 port
Protection	–	–	Surge	–	
Communication Protocol	Field Wireless	ISA100.11a	–		
	Management, configuration, etc.	–	IEEE1588PTP v2 *6, Proprietary *7		

*1: In outdoor wiring to Field Network or 100BASE-FX of Field Wireless Backbone, use optical fiber cables with a nonmetallic tension member, combining with YFGW610

*2: This product requires a wireless LAN access point for connection with YFGW410 in the wireless LAN in field wireless backbone.

*3: This is the maximum radio output at N-type connector for antenna connection. Radio output power depends on the region and the antenna type.

*4: 2-pole SC connector cannot be used due to the conduit hole size limitation. SC connector should use Short Boot type.

*5: The maximum length needs perfect conditions without an obstruction for radio wave transmission, using a standard antenna (2 dBi). The maximum length changes with the environmental conditions and installation situations of a site.

*6: Installation of these multiple product and YFGW410 in one field wireless subnet requires direct connection or the connection via IEEE1588PTP basis products.

*7: TCP based custom protocol used for communication between this product and YFGW410.

■ Performance

Network Size:

Max 100 field wireless devices are connectable

Display:

2-color luminescence LED displays the operating state of this product, and the operating state of wireless communications and cable communications.

Diagnosis Functions:

CPU failures, communication interface malfunctions, outside the range, abnormal settings.

Software Download Function:

The software inside this product and the software (communication firmware, sensor firmware) inside wireless field device can update via YFGW410.

■ Installation Environment

Temperature Range:

Operating:
-40 to +65°C (altitude: up to 3000 m)
Storage:
-40 to +85°C

Humidity Range:

Operating:
5 to 95% RH (non-condensation)
Storage:
5 to 95% RH (non-condensation)

Temperature Gradient:

Operating: ±10°C/h or less
Storage: ±20°C/h or less

Power Supply:

Voltage Range : 10.0-26.4 V DC
Rated Voltage: 24 V DC
Momentary Power Failure: Instant Disconnection
DC Power Supply Ripple Ratio: 1%p-p or less

Power Consumption:

Max. 3.5 W

Degrees of Protection:

IP66, NEMA4X

Vibration Resistance:

0.21 mm P-P (10-60 Hz), 3G (60-2k Hz)

Shock Resistance:

50G 11 ms

Noise Resistance:

Electric Field: 3 V/m or less (80 MHz-1 GHz)
 Electrostatic Discharges: 4 kV or less (contact discharge), 8 kV or less(aerial discharge)

Grounding:

Class-D grounding (no sharing ground with others)

Cooling:

Natural Air Cooling

■ **Regulatory Compliance Statements**

This device contains the wireless module which satisfies the following standards.

- * Please confirm that an installation region fulfills an applicable standard. If additional regulatory information and approvals are required, contact a Yokogawa representative.

Japanese Radio Law:

Construction Type Certification Number: 007-AA0011 (ISA100.11a), 007-AA0065/66 (Wireless LAN)

R&TTE Conformity Standards: **CE**

- Radio Spectrum: EN 300 328, EN 301 893
- EMC: EN 301 489-1, EN301 489-17, EN 61326-1 Class A, Table 2 (For use in industrial locations), EN 55011 Class A, group 1, EN 61000-6-2
- Health and Safety: EN 62311, EN 61010-1,

Regulation Conformity of the Wireless Module:

- FCC Approval (Part 15C,Part 15E)
- IC Approval (RSS-210)

Safety Requirements:

CSA C22.2 No. 61010-1

■ **Physical Specifications**

Connections:

Refer to “MODEL AND SUFFIX CODES.”

Housing Material:

Low copper cast aluminum alloy with polyurethane, mint-green paint (Munsell 5.6BG 3.3/2.9 or its equivalent)

Name Plate and Tag:

316 SST

Weight:

3.0 kg (without mounting bracket, and process connector.)

■ **SOFTWARE SPECIFICATIONS**

■ **Field Wireless Access Point Setting Tool**

This software is used for a setup and maintenance of this product. PC on which this software program installed is connected with this product via infrared communication.

■ **Specifications and System Requirements**

Software License:

1 license

Language:

Software (GUI): English
 Manual: Japanese or English

Hardware Operating Environment:

Item	Recommended System Requirement
Processor	Intel Core i5-2520M or equivalent, or higher
Memory	2 GB or more
Hard Disk	40 GB or more (Minimum free space 15 GB or more)
Display	Color: True Color (32 bits or more) Resolution: 1280 x 800 or higher
Communication Device	Ethernet Network Card

Software Operating Environment *1,*2:

OS	Type
Windows 10 Pro ^{*3}	32/64 bit
Windows 8.1 Pro Update ^{*4}	32/64 bit
Windows 7 Professional Service Pack 1 ^{*4}	32/64 bit
Windows Server 2012 R2 Standard Update ^{*4}	64 bit
Windows Server 2008 R2 Enterprise Service Pack 1 ^{*4}	64 bit
Windows Server 2008 Enterprise Service Pack 2 ^{*4}	32 bit

*1: Japanese version and English version are supported.

*2: For 64 bit OS, WOW64 (Windows 32-bit On Windows 64-bit) can be performed.

*3: Microsoft .NET Framework 4.6 is required.

*4: Microsoft .NET Framework 4.5.2 is required.

MODEL AND SUFFIX CODES

Model	Suffix Codes	Description
YFGW510	Field Wireless Access Point
Output signal	-A	ISA100.11a
	-C	ISA100.11a, IEEE802.11a/b/g *1
Communication interface	1	100 BASE-TX
	2	100 BASE-FX
	5	Wireless LAN
Housing	1	Low copper cast aluminum alloy
Electrical Connection	0	G1/2 female, two electrical connections, without blind plugs
	2	1/2 NPT female, two electrical connections, without blind plugs
	4	M20 female, two electrical connections, without blind plugs
	5	G1/2 female, two electrical connections, one blind plug *1*2
	7	1/2 NPT female, two electrical connections, one blind plug *1*2
	9	M20 female, two electrical connections, one blind plug *1*2
	A	G1/2 female, two electrical connections, one 316 SST blind plug *1
	C	1/2 NPT female, two electrical connections, one 316 SST blind plug *1
	D	M20 female, two electrical connections, one 316 SST blind plug *1
---	A	Always A
License	-S	Software license
Manual language	0	Japanese
	1	English
Software media	0	Provided with DVD-ROM
	1	None
Mounting bracket	B	304 SST 2-inch pipe mounting (for horizontal piping) *3
	D	304 SST 2-inch pipe mounting (for vertical piping) *3
	J	316 SST 2-inch pipe mounting (for horizontal piping) *3
	K	316 SST 2-inch pipe mounting (for vertical piping) *3
	N	None
ISA100.11a antenna	1	Detachable antenna 2 dBi (2.4 GHz)
	A	Antenna adaptor: N-type connector *4*5
Wireless LAN antenna (1) *6	N	None
	3	Remote antenna 2 dBi (2.4 GHz), antenna cable 3 m with mounting bracket
	4	Remote antenna 2 dBi (2.4 GHz, 5 GHz), antenna cable 3 m with mounting bracket
	A	Antenna adaptor: N-type connector *4*5
Wireless LAN antenna (2) *6	N	None
	3	Remote antenna 2 dBi (2.4 GHz), antenna cable 3 m*7 with mounting bracket
	4	Remote antenna 2 dBi (2.4 GHz, 5 GHz), antenna cable 3 m*7 with mounting bracket
	A	Antenna adaptor: N-type connector *4*5*7
---	A	Always A
---	A ..	Always A
Option codes		/□Optional specifications

- *1: Select in a wireless LAN client (communication interface code 5).
- *2: Select if optional specification KF27 or SF27 is not specified.
- *3: A bolt is required for wall attachment.
- *4: Select an antenna and a remote antenna cable. For details, refer to the accessory.
- *5: In order for the wireless output of an antenna to get the maximum which the area permits, adjustment by service of Yokogawa is required.
- *6: Wireless LAN antenna must be connected to this product by using external antenna cables.
- *7: Select only by 3, 4, and A of Wireless LAN antenna (1).

OPTIONAL SPECIFICATION (For Explosion Protected type)

Item	Description	Code
Factory Mutual (FM)	FM Nonincendive Approval Applicable standards: Class 3600:2011, Class 3611:2004, Class 3810:2005, NEMA 250:2003 Nonincendive for Class I, Division 2, Groups A, B, C and D; alternatively for Class I, Zone 2, Groups IIC. Suitable for Class II, Division 2, Groups F and G; Suitable for Class III, Division 1 Indoor/outdoor Type 4X in hazardous (classified) locations. Temperature Class T4 at Ta = -40°C to 65°C	FN17
	Explosionproof Approval	-
Canadian Standards Association (CSA)	CSA Non-Incendive Approval Certificate: 2655412 Applicable standards: C22.2 No.0-10, CAN/CSA-C22.2 No. 0.4-04, CAN/CSA-C22.2 No. 94-M91, C22.2 No. 213-M1987, CAN/CSA-C22.2 No. 60079-0:11, CAN/CSA-C22.2 No. 60079-15:12, CAN/CSA-C22.2 No. 61010-1-04, IEC 60529 :2001 Non-Incendive for Class I, Division 2, Groups A, B, C and D; Class II, Division 2, Groups F and G; Class III, Division I Non-Incendive Field Wiring Connections for Class I, Division 2, Groups A, B, C, D; Ex nA [nL] IIC T4. Ambient Temperature: -30 °C to +65 °C, Altitude: ≤ 3000m Enclosure: Type 4X, IP66 Cable parameters for antenna connection: Ccable: ≤ 4 nF, Lcable: ≤ 20 μH	CN17
	Flameproof Approval	-
ATEX	ATEX Type n declaration Applicable standard: EN60079-0: 2012+A11:2013, EN 60079-11:2012, EN 60079-15:2010 II 3 G Ex nA [ic] IIC T4 Gc Enclosure: IP66 Amb. Temp.(Tamb): -30 to 65°C (-22 to 149°F)	KN27
	ATEX Flameproof Approval Certificate: DEKRA 15ATEX0042 X Applicable Standard: EN 60079-0:2012+A11:2013, EN 60079-1:2007, EN 60079-11:2012 II 2 G Ex d [ib] IIC T4 Gb Um: 250 V Amb. Temp.(Tamb): -40 to 65°C (-40 to 149°F)	KF27
IECEX	IECEX Type n Approval Certificate: IECEX DEK 14.0028 Applicable standard: IEC60079-0:2011, IEC60079-11:2011, IEC60079-15:2010 Ex nA [ic] IIC T4 Gc Enclosure: IP66 Amb. Temp(Tamb): -30 to 65°C (-22 to 149°F)	SN27
	IECEX Flameproof Approval Certificate: IECEX DEK 15.0021X Applicable Standard: IEC 60079-0:2011, IEC 60079-1:2007, IEC 60079-11:2011 Ex d [ib] IIC T4 Gb Um: 250 V Amb. Temp.(Tamb): -40 to 65°C (-40 to 149°F)	SF27

OPTIONAL SPECIFICATIONS

Item	Description	Code
Coating	Coating change High anti-corrosion coating	X2

■ ACCESSORY

Item	Parts Number	Description
Remote antenna cable	F9915KU	3 m with mounting bracket
	F9915KV	13 m (3 m+10 m) with arrestor and mounting bracket
Antenna	F9915KW	2 dBi Standard Antenna (2.4 GHz) *1
	F9915KY	6 dBi High gain antenna (2.4 GHz) *2
	F9195VG	9 dBi High gain antenna (2.4 GHz) *2
	F9195VA	2 dBi Standard Antenna (2.4 GHz, 5 GHz) *1

*1: Standard antenna cannot perform direct connection to this product at wireless LAN.

*2: High gain antenna cannot perform direct connection to this product.

■ APPEARANCES

■ Communication interface: 1, 2

Wireless LAN Antenna (1) :

N

Wireless LAN Antenna (2) :

N

■ Communication interface: 5

Wireless LAN Antenna (1) :

3, 4, A

Wireless LAN Antenna (2) :

N

■ Communication interface: 5

Wireless LAN Antenna (1) :

3, 4, A

Wireless LAN Antenna (2) :

3, 4, A

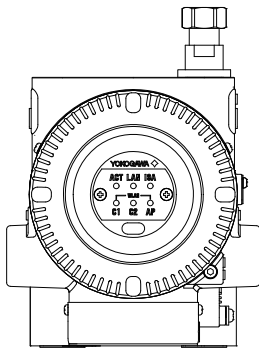

F01.ai

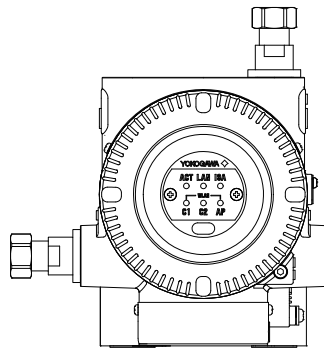

F02.ai

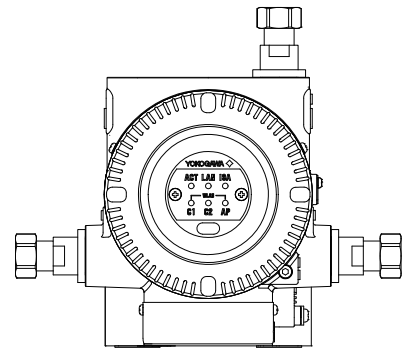

F03.ai

The cover is attached to N-type connector of the antenna. The cover is detached in connection of an antenna and external antenna cable.

EXTERNAL DIMENSIONS

2-inch pipe mounting (for horizontal piping)

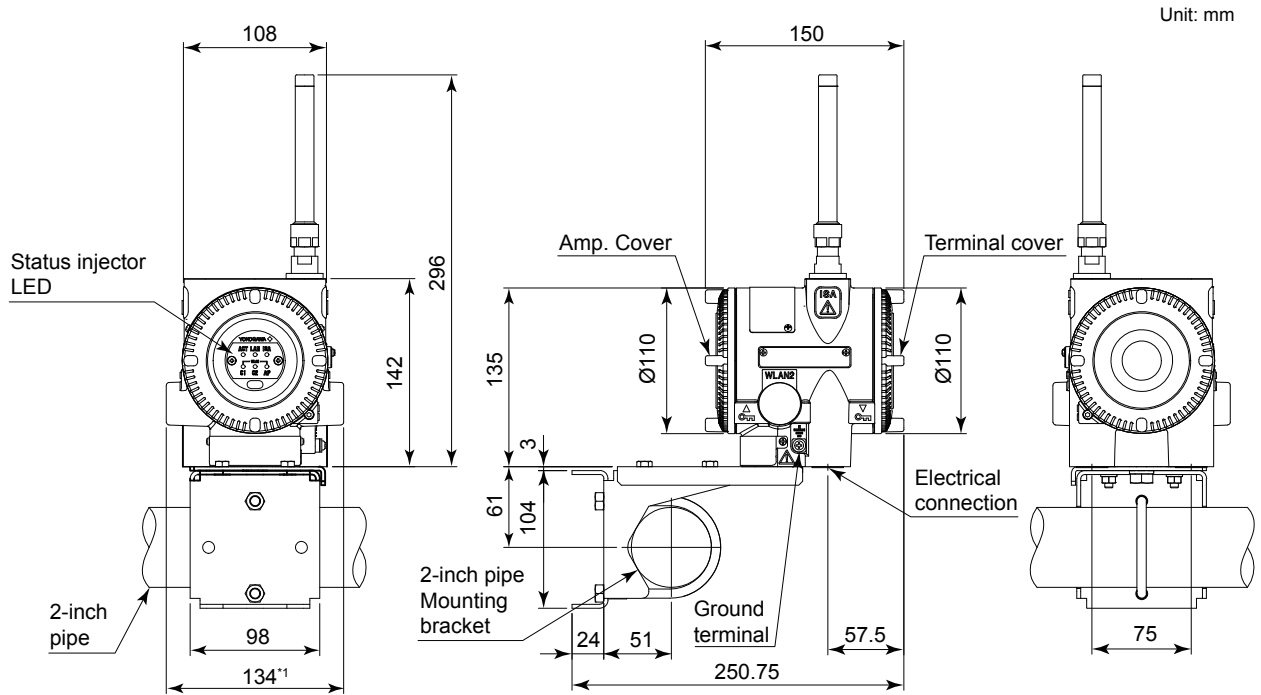

F04.ai

*1: In the case of selecting 3, 4, and A in Wireless LAN antenna (1): 167 mm
 In the case of selecting 3, 4, and A in Wireless LAN antenna (1) or (2): 204 mm

2-inch pipe mounting (for vertical piping)

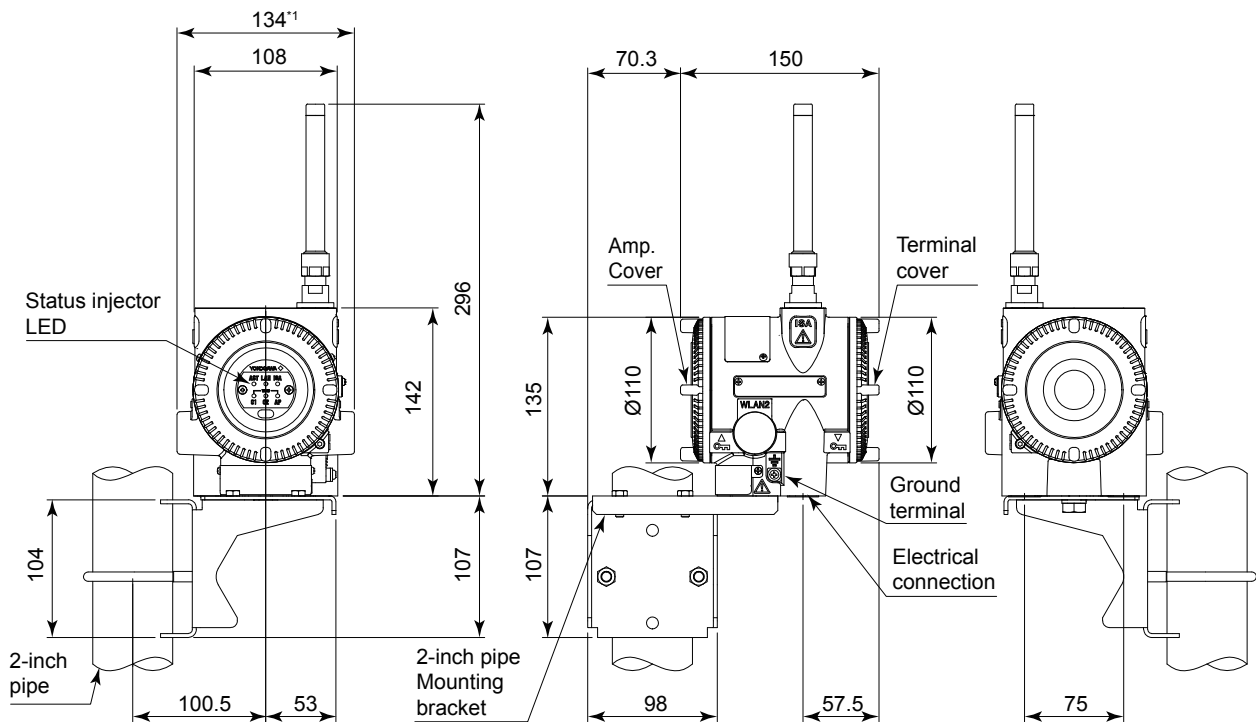

F05.ai

*1: In the case of selecting 3, 4, and A in Wireless LAN antenna (1): 167 mm
 In the case of selecting 3, 4, and A in Wireless LAN antenna (1) or (2): 204 mm

■ Antenna

- Standard Antenna (F9915KW)
Directional: Non-directional
Gain: 2 dBi

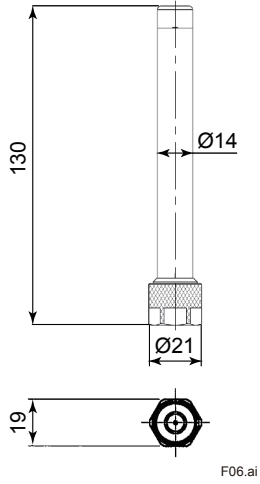

- High gain antenna (F9915KY)
Directional: Non-directional
Gain: 6 dBi

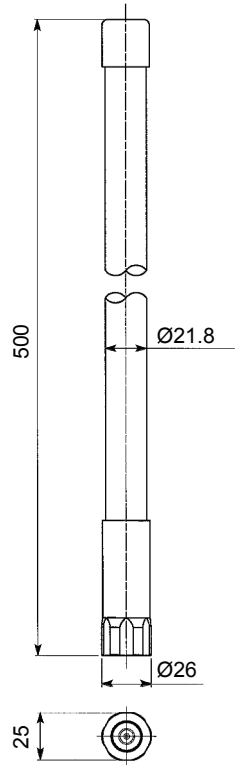

- High gain antenna (F9195VG)
Directional: Non-directional
Gain: 9 dBi

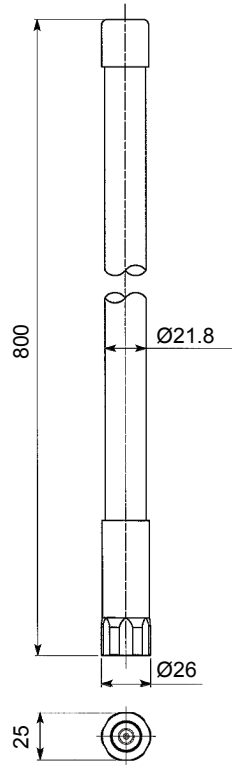

- Standard Antenna (F9195VA)
Directional: Non-directional
Gain: 2 dBi

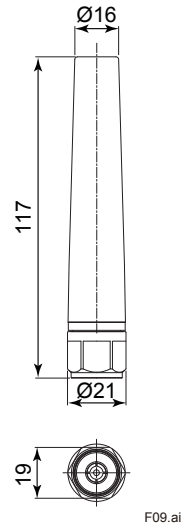

■ Remote antenna cable

- Cable 3 m

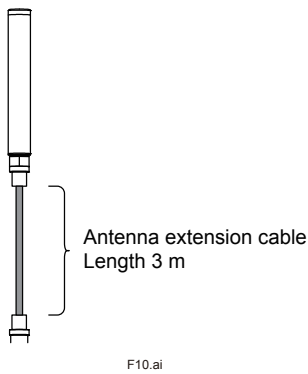

- Cable 13 m

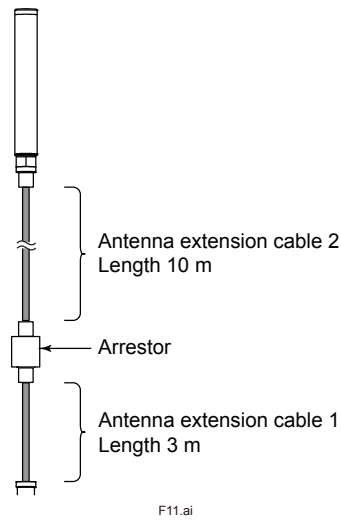

■ Antenna mounting bracket

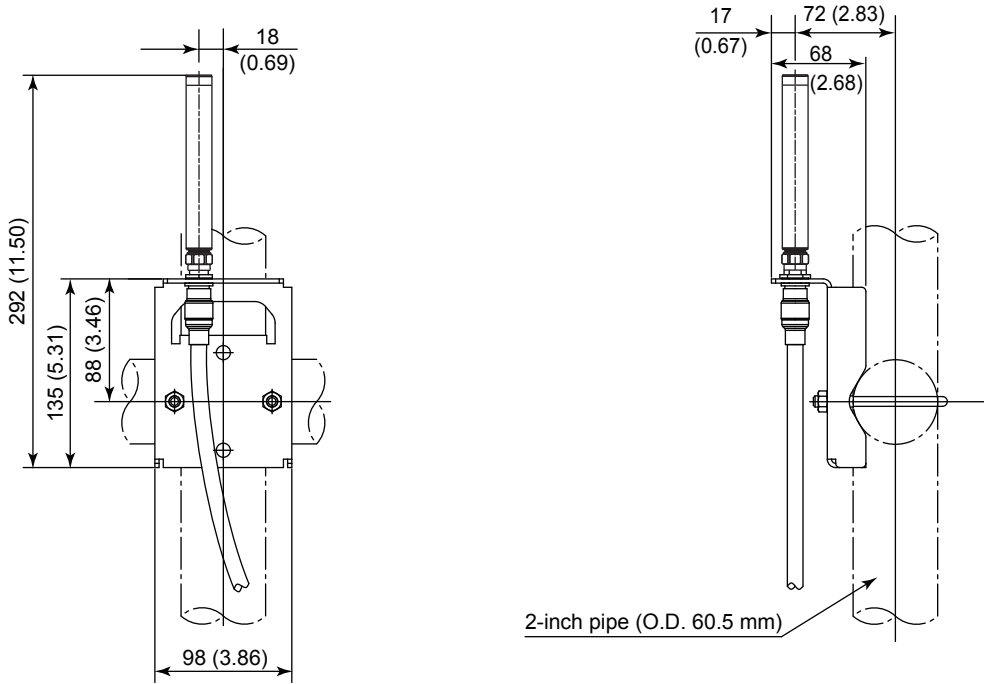

F12.ai

■ INFRARED CONFIGURATION

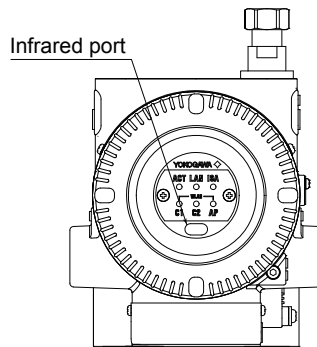

F13.ai

■ TERMINAL CONFIGURATIONS

■ Communication Interface: 1

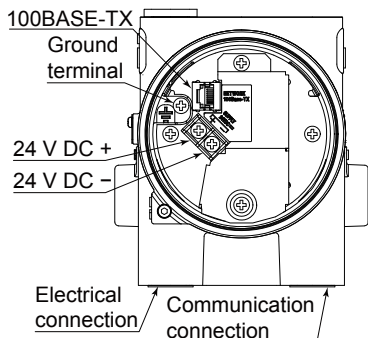

F14.ai

■ Communication Interface: 2

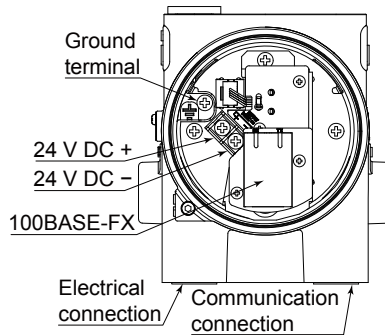

F15.ai

■ Communication Interface: 5 *1

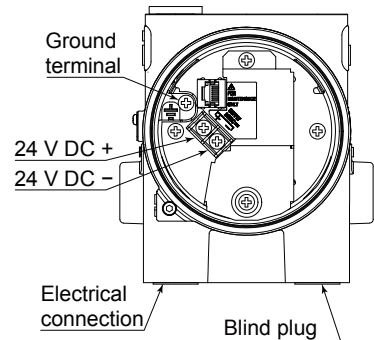

F16.ai

*1: Don't use the 100 BASE-TX connection by RJ-45 connector.

■ ORDERING INFORMATION

Specify the following when ordering

1. Model, suffix codes, and option codes
2. Tag Number (if required)

Specify Tag number (up to 16 letters) to be engraved on the tag plate. The specified letters are written on TAG_Name (16 letters) in the memory.

■ RELATED PRODUCTS GENERAL SPECIFICATIONS

Field Wireless System Overview :

Refer to GS 01W01A01-01EN

Field Wireless Management Station YFGW410:

GS 01W02D01-01EN

Field Wireless Media Converter YFGW610:

GS 01W02D02-01EN

■ TRADEMARK

YFGW is a registered trademark of Yokogawa Electric Corporation. Other product and company names appearing in this document are trademarks or registered trademarks of their respective holders.