



DTSX Series

Distributed Temperature Sensor



Distributed Temperature Sensing Enhances Site Safety, Asset Monitoring And Facilities Maintenance Function



Intrinsically safe leak detection, industrial process and asset monitoring systems

Ruggedized fiber optic sensor cable is deployed on the monitored area for continuous temperature monitoring along the entire cable length – no discrete sensors are required.

Areas of temperature change indicating leakage or other process abnormalities can be detected for corrective action.

Principal monitoring applications:

- Heat build up along industrial conveyor systems
- Cable tunnels, ducts, trays or rack systems where heat build-up could become a fire hazard
- Power cable operating temperatures for real-time thermal capacity rating and smart grid optimization
- Furnace chamber deterioration diagnosis via external wall surface temperature profiling

DTSX Fiber Optic Distributed Temperature Sensing System

Features:

- Easy process control system integration
- Wide operating environment range
- Compact and ultra-low power consumption
- Measure up to 50km
- Optional 2, 4, 16 channel modular optical switch
- Ethernet and Serial Modbus Communications
- LAS 2.0 and WITSML 1.3.1.1 data formatting option
- STARDOM Field Controller (NFPC050) option
- Field enclosure with solar panels, batteries, and wireless communications available

= LAS is Log ASCII Standard

= WITSML is Well-site Information Transfer Standard Markup Language

Bulletin 39J06B40-01E

www.yokogawa.co.jp

DTSX Series

Distributed Temperature Sensor



Application Examples

Wellbore Dynamics / Geophysical Monitoring

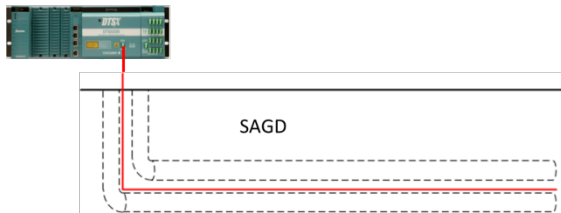

Wellbore temperature distribution profile can be used to detect thermal events related to steam breakthrough and oil & gas intake position, or other geophysical conditions.

Conveyor System Safety Monitoring

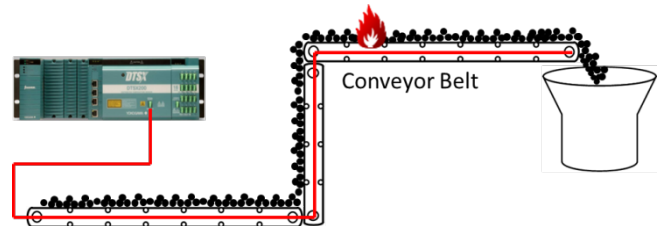

DTSX can be used to detect heat build up along conveyor systems indicating mechanical component failure or potential combustion conditions.

Cable Rack Monitoring

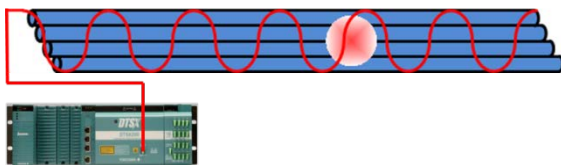

DTSX can be easily deployed along cable tunnels, ducts, trays or rack systems where heat build-up could indicate the potential for a fire hazard, or conductor over-temperature condition.

Pipeline Leak Detection System

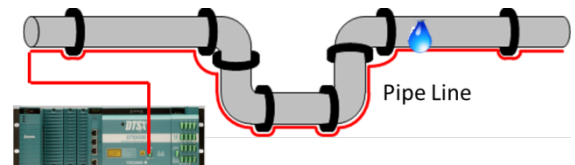

DTSX thermal profiles can be used to detect leak locations along LNG, liquid ammonia and other compressed gas pipelines where escaping content creates a thermal variance from normal background temperatures.

LNG Storage Tank

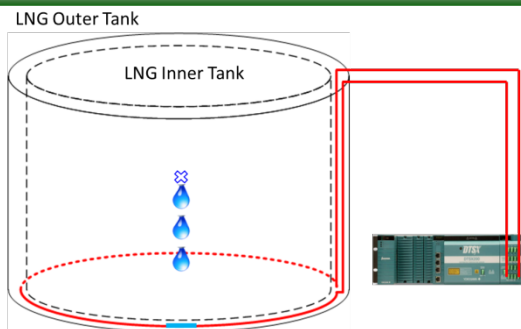

DTSX is commonly used for LNG tank leak detection by monitoring the expected differential in temperatures between the inner and outer liners comprising the tank system.

Furnace Chamber Skin Temperature Monitoring

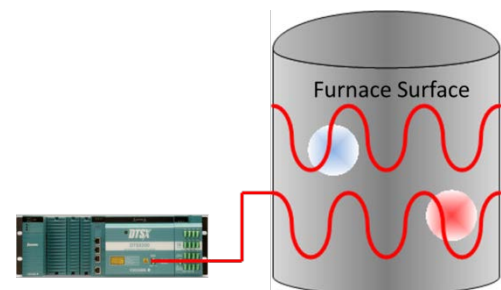

Furnace chamber or reactor vessel liner deterioration diagnosis via external wall surface temperature profiling.

DTSX Series

Distributed Temperature Sensor



System Configuration Example

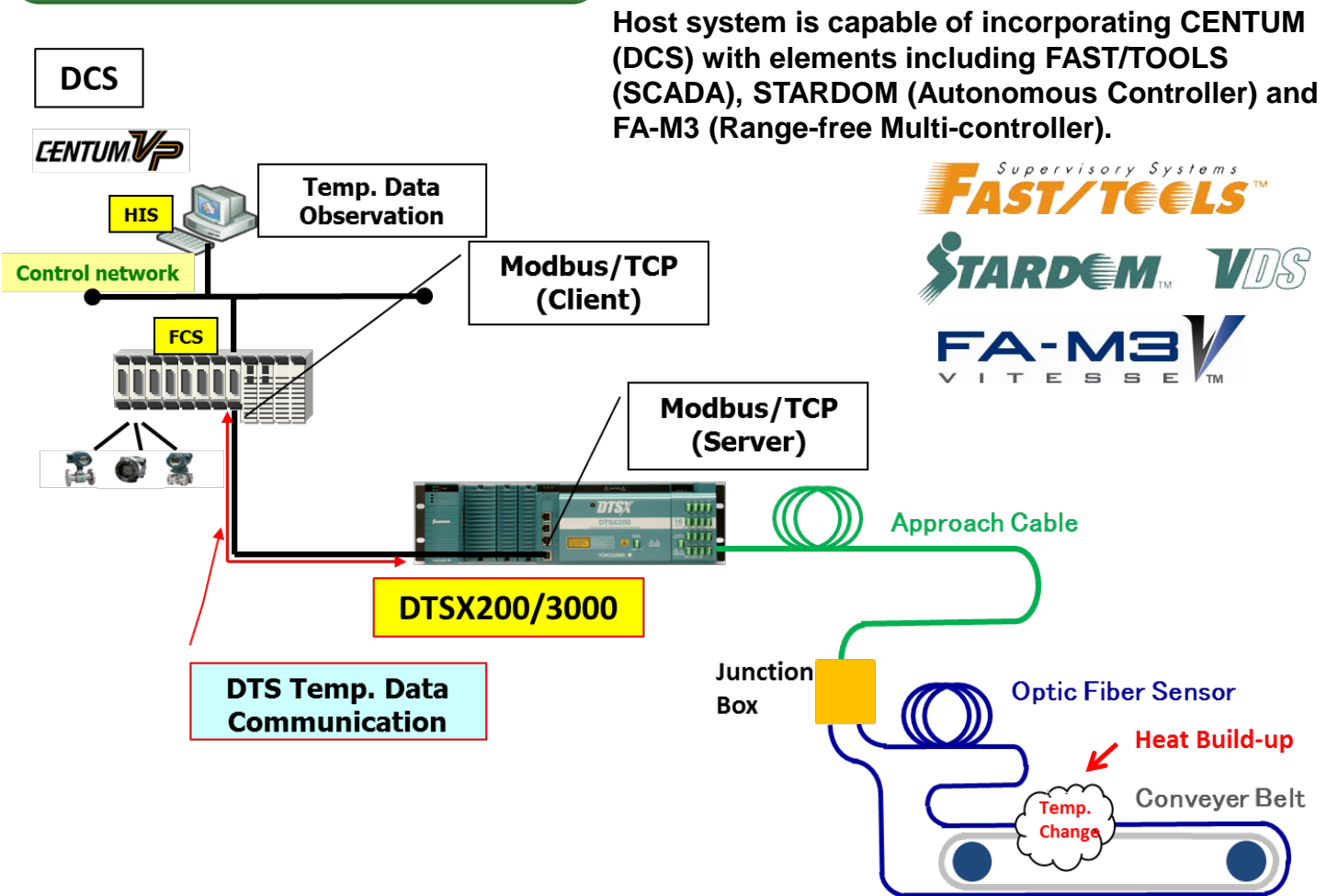

Optical Fiber Sensor Cable Example

	Cable Type	Temperature Range	Applications
1. FIMT (Fiber in Metal Tube) (SUS, Incoloy Alloy)		Low(-200°C~) Normal(-20~+70°C) High(~+300°C)	Furnace chamber LNG Pipeline, Tank Cable Rack System Conveyor System Oil & Gas Wellbore
2. FIMT with PE Sheath		-20~+70°C	Cable Rack System Conveyor System Tunnel Fire Detection
3. Flexible Metallic		-20~+70°C	Cable Rack System Conveyor System Room Temperature
4. Non-metallic (Flame Retardant Polyethylene)		-20~+70°C	Cable Rack System Conveyor System Room Temperature



DTSX Series

Distributed Temperature Sensor



DTSX3000

Long Range

Power Module

DTS Module

Optical Switch
Module
(Option)



DC10-30V
AC100V-240V
Selectable

2ch/4ch/16ch
Selectable

Variety Distance Range Lineup

- DTSX3000-S ~ 10km
- DTSX3000-N ~ 16km
- DTSX3000-M ~ 30km
- DTSX3000-L ~ 50km

Specification is available by GS (General Specification)
DTSX3000: GS 39J06B40-01, GS 39J02B40-01

DTS : Distributed Temperature Sensor

DTSX200

Mid-Range

Power Module

DTS Module

Optical Switch
Module
(Option)



DC10-30V
AC100V-240V
Selectable

2ch/4ch/16ch
Selectable

- DTSX200 ~ 6km

Specification is available by GS (General Specification)
DTSX200 : GS 39J06B45-01, GS 39J02B45-01

vigilantplant®

The clear path to operational excellence

SEE
CLEARLY

KNOW
IN ADVANCE

ACT
WITH AGILITY

VigilantPlant is Yokogawa's automation concept for safe, reliable, and profitable plant operations. VigilantPlant aims to enable an ongoing state of Operational Excellence where plant personnel are watchful and attentive, well-informed, and ready to take actions that optimize plant and business performance.

YOKOGAWA ELECTRIC CORPORATION
Industrial Automation Platform Business HQ

9-32, Nakacho 2-chome, Musashino-shi, Tokyo 180-8750, JAPAN

<http://www.yokogawa.com>

Phone: (81)-422-52-5735; Fax: (81)-422-52-0381

E-mail: OFS_Inquiry@cs.jp.yokogawa.com

[Ed:02] Printed in Japan, 410 (KP)

YOKOGAWA CORPORATION OF AMERICA
YOKOGAWA EUROPE B.V.
YOKOGAWA ENGINEERING ASIA PTE.LTD.

12530 West Airport Blvd, Sugar Land, Texas 77478, USA
Euroweg 2, 3825 HD Amersfoort, THE NETHERLANDS
5 Bedok South Road, Singapore 469270, SINGAPORE

<http://www.yokogawa.com/us/>
<http://www.yokogawa.com/eu/>
<http://www.yokogawa.com/sg/>

Trademarks

All brand or product names of Yokogawa Electric Corporation in this bulletin are trademarks or registered trademarks of Yokogawa Electric Corporation. All other company brand or product names in this bulletin are trademarks or registered trademarks of their respective holders.