

# General Specifications

## Model ZR22G, ZR402G, and ZR202G Direct In Situ Zirconia Oxygen Analyzers

EX4xi



### Overview

The ZR22 is a direct insertion (in-situ) type oxygen detector. This detector when inserted through the wall of a flue or furnace allows continuous monitoring of the oxygen concentration of combustion gas via a zirconia cell. Yokogawa offers three (3) types of oxygen detectors: low temperature, high temperature, and pressure compensated. These detectors are subject to harsh environments because they are directly mounted in combustion applications. We recommend utilizing one of the many accessories Yokogawa has available to increase the life of the detector.



ZR22G

ZR402G



ZR202G

### -Features

- The built-in heater assembly of the probe can be replaced on site, reducing maintenance costs.
- The probe uses a long-life, high reliability Zirconia sensor
- The probe uses three-reference air supply methods (natural air convection, instrument air, and pressure compensated) in its applications.
- The separate type converter incorporates an LCD touch-screen for ease of operation.
- This converter is used as an oxygen analyzer.
- The integrated type integrates both probe and converter, to reduce wiring, piping, and installation costs. This type of unit uses an optical switch for ease of operation at the site.
- Remote maintenance using digital communications (HART®) reduces maintenance costs.

## Basic System Configuration

### System configuration Example 1 of Separate type Analyzer

- Automatic calibration system uses clean, dry instrument air for reference gas. For the calibration gas, a standard gas cylinder may be used for more accurate calibration.
- Applications: Oxygen concentration monitoring and control in large boilers and in heating furnaces, and the like.

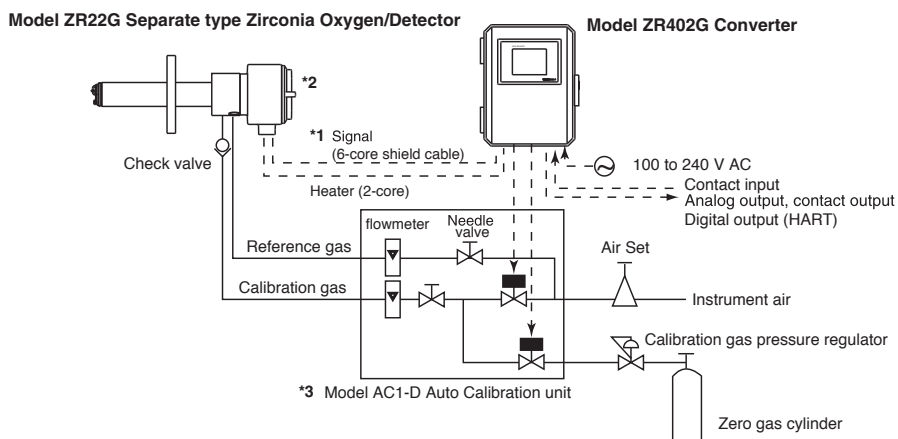

F03.EPS

### System configuration Example 1 of Integrated type Analyzer

- For an integrated type as shown in the figure above.
- Applications: Oxygen concentration monitoring and control of packaged boilers, on-board ship boilers, and heating furnaces.

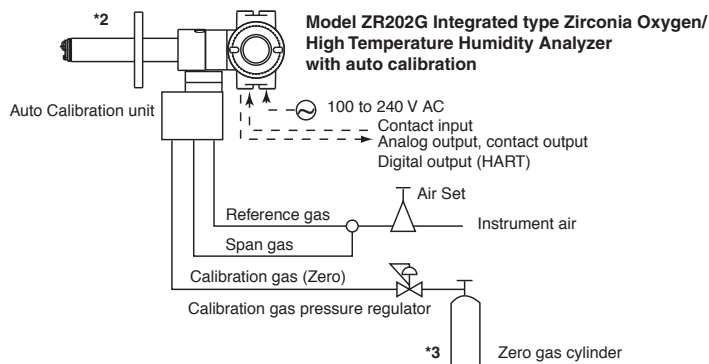

Note:  
The installation ambient temperature limits range for integrated type analyzer is -20 to 55 °C.

F05.EPS

\*1 Shield cable:

Use shielded signal cables, and connect the shields to the FG terminal of the converter.

\*2 Select the desired probe from the Probe Configuration table on page 4.

\*3 When a zirconia oxygen analyzer is used, 100% N<sub>2</sub> gas cannot be used as the zero gas. Use approx. 1 vol% O<sub>2</sub> gas (N<sub>2</sub>-balanced).

## STANDARD SPECIFICATIONS

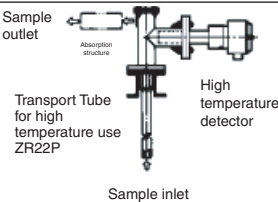
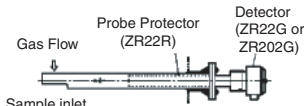
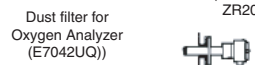
Process gas temperature 0 to 700°C				Process gas temperature 0 to 1800°C	
Mounting	Insertion length	General-use Probe	Application	High temperature detector	Application
Horizontal to vertical	0.4 to 2 m		Boiler Heating furnace		Heating furnace
Vertical	2.5 m or more				
Horizontal to vertical	3 m or less		For pulverized coal boiler with gas flow velocity 10 m/s or more		
Horizontal to vertical	0.4 to 2 m		Black liquid recovery boiler Cement Kiln		
Vertical	2.5 m or more				

F06.EPS

### Application Example

Separate and integrated type Zirconia Oxygen Analyzers

- Large, medium and small boilers (boilers for power generation: heavy oil, gas or coal)
- Various industrial furnaces (refinery process/iron manufacture heating furnace, coal kiln, and black liquid recovery boilers)

For other applications, contact Yokogawa Electric Corporation.

### General Specifications

#### Oxygen Analyzer System

Measurement: Oxygen concentration in combustion exhaust gas and mixed gas (excluding flammable gases).

Measurement System: Zirconia system

Oxygen Concentration: 0.01 to 100 vol% O<sub>2</sub>

Output Signal: 4 to 20 mA DC (maximum load resistance 550Ω)

Measurement Range: Any setting in the range of 0 to 5 through 0 to 100 vol% O<sub>2</sub>

Digital Communication (HART®): 250 to 550Ω, depending on number of field devices connected to the loop (multi-drop mode).

Display Range: 0 to 100 vol% O<sub>2</sub>

Warm-up Time: Approx. 20 min.

Repeatability: ±0.5% Maximum value of set range.

Linearity: (Excluding standard gas tolerance)

±1% Maximum value of set range.

Drift: Both zero and span ±2% Maximum value of set range/month

Response Time: Response of 90% within 5 seconds. (Measured after gas is introduced from calibration-gas inlet and analog output starts changing.)

### 1. ZR22G Separate type Zirconia Oxygen Detector

#### Oxygen Analyzer

Sample Gas Temperature: 0 to 700°C (Probe only); 700 to 1800°C (with High Temperature Probe Adapter)

Sample Gas Pressure: -0.725 to +36.3 psi (+0.725 to +36.3 requires pressure compensation.)

Probe Length: 0.15, 0.4, 0.7, 1.0, 1.5, 2.0, 2.5, 3.0, 3.6, 4.2, 4.8, 5.4m

Probe Material: SUS 316 (JIS)

Ambient Temperature: -20 to +150°C (-4 to 302°F)

Reference Air System: Natural Convection, Instrument Air, or pressure compensated

Instrument Air System: Pressure; 29psi + the pressure inside the furnace (It is recommended to use clean, dry plant air.)

Consumption; Approx. 1LPM

Wetted Material: SUS 316 (JIS), Zirconia, SUS 304 (JIS) (flange), Hastelloy B, (Inconel 600, 601),

Construction: Heater and thermocouple replaceable construction. Non explosion-proof.  
Equivalent to NEMA4X/IP 66 (recirculation to furnace with pressure compensated only)  
Terminal Box Case: Material; Aluminum alloy  
Terminal Box Paint Color: Case; Off-white (Munsell 5.6BG3.3/2.9  
Cover; Moss green (Munsell 5.6BG3.3/2.9)  
Finish: Polyurethane corrosion-resistance coating  
Gas Connection: 1/4 FNPT  
Wiring Connection: 1/2 NPT  
Installation: Flange mounting

**Weight:**

Insertion length of 0.4 m: approx. 6 kg (JIS 5K-65) / approx. 11 kg (ANSI 150-4)  
Insertion length of 1.0 m: approx. 8 kg (JIS 5K-65) / approx. 13 kg (ANSI 150-4)  
Insertion length of 1.5 m: approx. 10 kg (JIS 5K-65) / approx. 15 kg (ANSI 150-4)  
Insertion length of 2.0 m: approx. 12 kg (JIS 5K-65) / approx. 17 kg (ANSI 150-4)  
Insertion length of 3.0 m: approx. 15 kg (JIS 5K-65) / approx. 20 kg (ANSI 150-4)  
Insertion length of 3.6 m: approx. 17 kg (JIS 5K-65) / approx. 22 kg (ANSI 150-4)  
Insertion length of 4.2 m: approx. 19 kg (JIS 5K-65) / approx. 24 kg (ANSI 150-4)  
Insertion length of 4.8 m: approx. 21 kg (JIS 5K-65) / approx. 26 kg (ANSI 150-4)  
Insertion length of 5.4 m: approx. 23 kg (JIS 5K-65) / approx. 28 kg (ANSI 150-4)

## 2. ZR402G Separate type Zirconia Oxygen Analyzer, Converter

Operated using an LCD touchscreen on the converter.

Display: LCD display of size 320 by 240 dot with touchscreen.  
Output Signal: 4 to 20 mA DC, two points (maximum load resistance 550Ω)  
Contact Output Signal: four points (one is fail-safe, normally open)  
Contact Input: two points  
Auto-calibration Output: Two points (for dedicated auto-calibration unit)  
Ambient Temperature: -20 to +55°C  
Storage Temperature: -30 to +70°C  
Ambient Humidity : 0 to 95 %RH (non-condensing)  
Installation Altitude: 2000 m or less  
Category based on IEC 1010: II (Note)  
Pollution degree based on IEC 1010: 2 (Note)  
Note: Installation category, called over-voltage category, specifies impulse withstand voltage. Category II is for electrical equipment.  
Pollution degree indicates the degree of existence of solid, liquid, gas or other inclusions which may reduce dielectric strength. Degree 2 is the normal indoor environment.  
Power Supply Voltage: Ratings; 100 to 240 V AC  
Acceptable range; 85 to 264 V AC

Power Supply Frequency: Ratings; 50/60 Hz  
Acceptable range; 45 to 66 Hz  
Power Consumption: Max. 300 W, approx. 100 W for ordinary use.

**Safety and EMC conforming standards**

Safety: Conforms to EN 61010-1: 1993  
CSA C22.2 No.61010-1 certified  
UL 3111-1 certified

EMC: Conforms to EN 61326: 1998

Maximum Distance between Probe and Converter:

Conductor two-way resistance must be 10Ω or less (when a 1.25 mm<sup>2</sup> cable or equivalent is used, 300 m or less.)

Construction: Outdoor installation, NEMA4X/IP66 or equivalent (with conduit holes completely sealed with a plastic cable gland optional)

Wiring Connection: G1/2, Pg13.5, M20 by 1.5mm, 1/2 NPT, eight holes

Installation: Panel, wall or pipe mounting

Case: Aluminum alloy

Paint Color: Door; Silver gray (Munsell 3.2PB7.4/1.2)  
Case; Silver gray (Munsell 3.2PB7.4/1.2)

Finish: Polyurethane corrosion-resistance coating

Weight: Approx. 6 kg

### Functions

Display Functions:

Value Display; Displays values of the measured oxygen concentration

Graph Display; Displays trends of measured oxygen concentration

Data Display; Displays various useful data for maintenance, such as cell temperature, reference junction temperature, maximum/minimum oxygen concentration, or the like.

Status Message; Indicates an alarm or error occurrence with flashing of the corresponding icon. Indicates status such as warming-up, calibrating, or the like by icons.

Alarm, Error Display: Displays alarms such as "Abnormal oxygen concentration" or errors such as "Abnormal cell e.m.f." when any such status occurs.

Calibration Functions:

Auto-Calibration; Requires the Auto-calibration Unit. It calibrates automatically at specified intervals.

Semi-auto Calibration; Requires the Auto-calibration Unit. Input calibration direction on the touchscreen or contact, then it calibrates automatically afterwards.

Manual Calibration; Calibration with opening/closing the valve of calibration gas in operation interactively with an LCD touchscreen.

Blowback Function:

Output through the contact in the set period and time. Auto/semi-auto selectable.

Maintenance Functions:

Can operate updated data settings in daily operation and checking. Display data settings,

	and one mA digital output point (HART®) (minimum load resistance of 250Ω).
Setup Functions: Equipment settings, current output data settings, alarm data settings, contact data settings, other settings.	Range: any setting between 0 to 5 through 0 to 100 vol% O <sub>2</sub> in 1 vol% O <sub>2</sub> , or partial range is available (Maximum range value/minimum range value 1.3 or more)
Self-diagnosis: This function diagnoses conditions of the converter or the probe and indicates when any abnormal condition occurs.	For the log output, the minimum range value is fixed at 0.1 vol% O <sub>2</sub> . 4 to 20 mA DC linear or log can be selected.
Password Functions: Enter your password to operate the analyzer excepting data display. Individual passwords can be set for maintenance and setup.	Input/output isolation Output damping: 0 to 255 seconds. Hold/non-hold selection, preset value setting possible with hold.
Display and Setting Content: Measuring Related items: Oxygen concentration (vol% O <sub>2</sub> ), output current value (mA), air ration, moisture quantity (in hot gases) (vol% H <sub>2</sub> O)	Contact Output: Four points, contact capacity 30 V DC 3 A, 250 V AC 3 A (resistive load). Three of the output points can be selected to either normally energized or normally de-energized status.
Display Items: Cell temperature (°C), thermocouple reference junction temperature (°C), maximum/minimum/average oxygen concentration (vol% O <sub>2</sub> ), cell e.m.f. (mV), cell resistance (Ω), cell condition (in four grades), heater on-time rate (%), calibration record (ten times), time (year/month/day/hour/minute)	Delayed functions (0 to 255 seconds) and hysteresis function (0 to 9.9 vol%O <sub>2</sub> can be added to high/low-alarms. The following functions are programmable for contact outputs.
Calibration Setting Items: Span gas concentration (vol% O <sub>2</sub> ), zero gas concentration (vol% O <sub>2</sub> ), calibration mode (auto, semi-auto, manual), calibration type and method (zero-span calibration, zero calibration only, span calibration only), stabilization time (min.sec), calibration time (min.sec), calibration period (day/hour), starting time (year/month/day/hour/minute)	(1) Abnormal, (2) High-high alarm, (3) High-alarm, (4) Low-low alarm, (5) Low-alarm, (6) Maintenance, (7) Calibration, (8) Range switching answer-back, (9) Warm-up, (10) Calibration-gas pressure decrease (answer back of contact input), (11) Temperature high-alarm, (12) Blowback start, (13) Flameout gas detection (answer back of contact input)
Equipment Related Items: Measuring gas selection	Contact Input: Two points, voltage-free contacts
Output Related Items: Analog output/output mode selection, output conditions when warming-up/maintenance/calibrating (during blowback)/abnormal, 4 mA/20 mA point oxygen concentration (vol% O <sub>2</sub> ), time constant, preset values when warming-up/maintenance/calibrating (during blowback)/abnormal, output preset values on abnormal	The following functions are programmable for contact inputs: (1) Calibration-gas pressure decrease alarm, (2) Range switching - fixed range if use range switching (3) External calibration start, (4) Process alarm (if this signal is received, the heater power turns off), (5) Blowback start
Alarm Related Items: Oxygen concentration high-alarm/high-high alarm limit values (vol% O <sub>2</sub> ), oxygen concentration low-alarm/low-low alarm limit values (vol% O <sub>2</sub> ), oxygen concentration alarm hysteresis (vol% O <sub>2</sub> ), oxygen concentration alarm detection, alarm delay (seconds)	Contact capacity: Off-state leakage current: 3 mA or less Self-diagnosis: Abnormal cell, abnormal cell temperature (low/high), abnormal calibration, defective A/D converter, defective digital circuit
Contact Related Items: Selection of contact input 1 and 2, selection of contact output 1 to 4 (abnormal, high-high alarm, high-alarm, low-alarm, low-low alarm, maintenance, calibrating, range switching, warming-up, calibration-gas pressure decrease, temperature high-alarm, blowback, flameout gas detection)	Calibration: Method; zero/span calibration Calibration mode; automatic, semi-automatic and manual (All are operated interactively with an LCD touchscreen). Either zero or span can be skipped. Zero calibration-gas concentration setting range: 0.3 to 100 vol% O <sub>2</sub> (0.01 vol% O <sub>2</sub> in smallest units). Span calibration-gas concentration setting range: 4.5 to 100 vol% O <sub>2</sub> (0.01 vol%vol% O <sub>2</sub> in smallest units). Use nitrogen-balanced mixed gas containing 10 vol% O <sub>2</sub> scale of oxygen and 80 to 100 vol% O <sub>2</sub> scale of oxygen for standard zero-gas, and standard span-gas respectively.
Converter Output: Two points mA analog output (4 to 20 mA DC) (maximum load resistance of 550Ω)	Calibration period; date/time setting: maximum 255 days



### 3. ZR202G Integrated type Zirconia Oxygen Analyzer

#### Oxygen Analyzer

Display: 6-digit LCD  
 Switch: Three optical switches  
 Output Signal: 4 to 20 mA DC, one point (maximum load resistance 550Ω)  
 Digital Communication (HART®): 250 to 550Ω, depending on quantity of field devices connected to the loop (multi-drop mode).  
 Contact Output Signal: Two points (one is fail-safe, normally open)  
 Contact Input Signal: Two points  
 Sample Gas Temperature: 0 to 700°C  
 High temperature service— greater than 700°C is not available.  
 Sample Gas Pressure: -0.725 to 36.3 psi (+0.725 to +36.3 requires pressure compensation.)  
 Probe Length: 0.4, 0.7, 1.0, 1.5, 2.0, 2.5, 3.0m  
 Probe Material: SUS 316 (JIS)  
 Ambient Temperature: -20 to +55°C (-5 to +70°C on the case surface)  
 Storage Temperature: -30 to +70°C  
 Ambient Humidity: 0 to 95% RH (non-condensing)  
 Installation Altitude: 2000 m or less  
 Category based on IEC 1010: II (Note)  
 Pollution degree based on IEC 1010: 2 (Note)  
 Power Supply Voltage: Ratings; 100 to 240 V AC  
 Acceptable range; 85 to 264 V AC  
 Power Supply Frequency: Ratings; 50/60 Hz  
 Acceptable range; 45 to 66 Hz  
 Power Consumption: Max. 300 W, approx. 100 W for ordinary use.

Safety and EMC conforming standards  
 Safety: Conforms to EN 61010-1: 1993  
 CSA C22.2 No.1010-1 certified  
 UL 3111-1 certified  
 EMC: Conforms to EN 61326: 1998  
 Reference Air System: Instrument air, or pressure compensated  
 Instrument Air System (excluding Natural Convection):  
 Pressure; 29 psi + the pressure inside the furnace. (It is recommended to use clean, dry plant air.)  
 Consumption; Approx. 1NI/min  
 Material in Contact with Gas: SUS 316 (JIS), Zirconia, SUS 304 (JIS) (flange), Hastelloy B, (Inconel 600, 601)  
 Construction: Heater and thermocouple replaceable construction. Non explosion-proof.  
 Equivalent to NEMA 4X/IP66 (recirculation to furnace with pressure compensations only)  
 Gas Connection: 1/4 FNPT  
 Wiring Connection: 1/2 NPT select one type (4 pieces)  
 Installation: Flange mounting  
 Case: Aluminum alloy  
 Paint Color: Cover; mint green (Munsell 5.6BG3.3/2.9)  
 Case: mint green (Munsell 5.6BG3.3/2.9)  
 Finish: Polyurethane corrosion-resistance coating

#### Weight:

Insertion length of 0.4 m: approx. 8 kg (JIS 5K-65) / approx. 13 kg (ANSI 150-4)  
 Insertion length of 1.0 m: approx. 10 kg (JIS 5K-65) / approx. 15 kg (ANSI 150-4)  
 Insertion length of 1.5 m: approx. 12 kg (JIS 5K-65) / approx. 17 kg (ANSI 150-4)  
 Insertion length of 2.0 m: approx. 14 kg (JIS 5K-65) / approx. 19 kg (ANSI 150-4)  
 Insertion length of 3.0 m: approx. 17 kg (JIS 5K-65) / approx. 22 kg (ANSI 150-4)

#### Functions

Display Function: Displays values of the measured oxygen concentration, etc.

Alarm, Error Display: Displays alarms such as “AL-06” or errors such as “Err-01” when any such status occurs.

#### Calibration Functions:

Auto-calibration; Requires the auto-calibration Unit. It calibrates automatically at specified intervals.

Semi-auto Calibration; Requires the auto-calibration unit. Input calibration starts signal by optical switch or contact, then it calibrates automatically afterwards.

Manual Calibration; Calibration with opening/closing the valve of calibration gas in operation interactively with the optical switch.

#### Maintenance Functions:

Can operate updated data settings in daily operation and checking. Display data settings, calibration data settings, test settings (current output loop check, input/output contact check).

#### Setup Functions:

Initial settings suit for the plant conditions when installing the converter. Current output data settings, alarm data settings, contact data settings, other settings.

#### Display and setting content:

Display Related Items: Oxygen concentration (vol% O<sub>2</sub>), Output current value (mA), air ratio, moisture quantity (in hot gases) (vol% H<sub>2</sub>O), Cell temperature (°C), thermocouple reference junction temperature (°C), maximum/minimum/average oxygen concentration (vol% O<sub>2</sub>), cell e.m.f. (mV), cell internal resistance (Ω), cell condition (in four grades), heater on-time rate (%), calibration record (ten times), time (year/month/day/hour/minute)

Calibration Setting Items: Span gas concentration (vol% O<sub>2</sub>), zero-gas concentration (vol% O<sub>2</sub>), calibration mode (auto, semi-auto, manual), calibration type and method (zero-span calibration, zero calibration only, span calibration only), stabilization time (min.sec), calibration time (min.sec), calibration period (day/hour), starting time (year/month/day/hour/minute)

Output Related Items: Analog output/output mode selection, output conditions when warming-up/maintenance/calibrating/abnormal, 4 mA/ 20 mA point oxygen concentration (vol% O<sub>2</sub>), time constant, preset values when warming-up/maintenance/calibrating/abnormal, output preset values on abnormal

Alarm Related Items: Oxygen concentration high-alarm/high-high alarm limit values (vol% O<sub>2</sub>), Oxygen concentration low-alarm/low-low alarm limit values (vol% O<sub>2</sub>), oxygen concentration alarm hysteresis (vol% O<sub>2</sub>), oxygen concentration alarm detection, alarm delay (seconds)

Contact Related Items: Selection of contact input 1 and 2, selection of contact output 1 and 2 (abnormal, high-high alarm, high-alarm, low-alarm, low-low alarm, maintenance, calibrating, range switching, warming-up, calibration-gas pressure decrease, flameout gas detection (answer back of contact input)

Converter Output: One mA analog output point (4 to 20 mA DC (maximum load resistance of 550 Ω) with mA digital output point (HART®) (minimum load resistance of 250 Ω). Range: any setting between 0 to 5 through 0 to 100 vol% O<sub>2</sub>, and partial range is available (Maximum range value/minimum range value 1.3 or more)

For the log output, the minimum range values are fixed at 0.1 vol% O<sub>2</sub>.

4 to 20 mA DC linear or log can be selected.

Input/output isolation

Output damping: 0 to 255 seconds.

Hold/non-hold selection, preset value setting possible with hold.

Contact Output: Two points, contact capacity 30 V DC 3 A, 250 V AC 3 A (resistive load)

One of the output points can be selected to either normally energized or normally de-energized status.

Delayed functions (0 to 255 seconds) and hysteresis function (0 to 9.9 vol% O<sub>2</sub>) can be added to high/low-alarms.

The following functions are programmable for contact outputs.

(1) Abnormal, (2) High-high alarm, (3) High-alarm, (4) Low-low alarm, (5) Low-alarm, (6) Maintenance, (7) Calibration, (8) Range switching answer-back, (9) Warm-up, (10) Calibration-gas pressure decrease (answer back of contact input), (11) Flameout gas detection (answer back of contact input).

Contact Input: Two points, voltage-free contacts

The following functions are programmable for contact inputs:

(1) Calibration-gas pressure decrease alarm, (2) Range switching - fixed ranges if use range switching, (3) External calibration start, (4) Process alarm (if this signal is received, the heater power turns off)

Self-diagnosis: Abnormal cell, abnormal cell temperature (low/high), abnormal calibration, A/D converter abnormal, digital circuit abnormal

Calibration: Method; zero/span calibration  
Calibration mode; automatic, semi-automatic and manual (All are operated using optical switches). Either zero or span can be skipped. Zero-calibration gas concentration setting range: 0.3 to 100 vol% O<sub>2</sub> (in 0.01 vol% O<sub>2</sub>). Span-calibration gas concentration setting range: 4.5 to 100 vol% O<sub>2</sub> (in 0.01 vol% O<sub>2</sub>). Use nitrogen-balanced mixed gas containing 10 vol% O<sub>2</sub> scale of oxygen for standard zero-gas, and 80 to 100 vol% O<sub>2</sub> scale of oxygen for standard span-gas.  
Calibration period; date/time setting: maximum 255 days

Input/output isolation

Output damping: 0 to 255 seconds.

Hold/non-hold selection, preset value setting possible with hold.

## Model and Suffix Codes

### 1. Separate type Zirconia Oxygen Converter

Model	
ZR402G-T-E-E-A	Zirconia Oxygen Humidity Analyzer Converter
Options	
/HS	Preset for Humidity Measurement
/H	Hood
/SCT	Stainless Steel Tag Plate
Accessories for ZR402G	
IM 11M12A01-02E	Instruction Manual ZR402

Note: When the ZR22 is used with existing older model converters, ZA8C, AV8C and HA400, ROM replacement and addition of a cold junction temperature compensation board are required. These ROMs are included when the /ZA, /AV, or /HA options indicated in the ZR22G model code.

Model	Language	English
ZA8C		M1234FH-A
HA400 (kg)		M1234FM-A
HA400 (%)		M1234FK-A
AV8C		M1234FF-A

T03\_01.eps

## 2. Separate type Zirconia Oxygen / High Temperature Humidity Analyzer, Detectors

### Model ZR22G ZIRCONIA OXYGEN DETECTOR

**HOW TO ORDER:**  
Specify the model number, add the option code selection(s) to the model number and total the prices to arrive at list price.

The ZR22 requires a conversion kit if used with an AV8C, ZA8C or HA400. Select the /ZA for use with ZA8C or /AV for use with AV8C. See note 4.

Code	Model Description	Note
ZR22G	Zirconia Oxygen/Humidity Analyzer Detector	
	Length	
-015	0.15 meter for use w/ZR22P high temp adapter	
-040	0.4 meter	
-070	0.7 meter	
-100	1 r mete	
-150	1.5 meter	
-200	2 r mete	
-250	2.5 meter	
-300	3 meter	
-360	3.6 meter	1
-420	4.2 meter	1
-480	4.8 meter	1
-540	5.4 meter	1
	Wetted Material	
-S	Stainless Steel	
-C	Stainless Steel with Inconel cal gas tube	
	Flange	
-A	ANSI CLASS 150-2-RF (equivalent) flange	
-C	ANSI CLASS 150-4-RF (equivalent) flange	
-Q	JIS 5K32A (for high temp probe adapter) ZR22P flange	
-W	Westinghouse flange	
	Reference Air	
-E	External connection	
-P	Pressure compensation (for applications above 20" H2O)	
	Gas Thread	
-T	1/4 inch NPT	
	Connection Box Thread	
-T-E-A	NPT (1/2NPT)	
-Q-E-A	Quick connect for cables (must select /QF on cables)	
	Options	
/AC24	Integral auto-calibration unit mounted for indoor installations	
/ZA	For detector use with ZA8C	
/AV	For detector use with AV8C	
/HA	For detector use with HA400	
/D	Derekane coating for high sulfur applications	2
/C	Inconel bolt, Oring	
/CV	Check valve	3
/SCT	Stainless steel tag plate	
/PT	Printed tag	
	Spare Parts - ZR22	
E7042UD	Universal cell assembly kit (for ZO21D/ZR22/ZR202)	
M1234PT-A	7-pin terminal box connector (-Q option)	
M1234PT-A	3-pin terminal box connector (-Q option)	
M1200DB-06	High temperature fly ash filter for ZR22	
M1234SE-A	Self-cleaning high temp flyash filter for ZR22	
M1234FF-A	AV8C single channel conversion kit (for one probe)	4
M1234FH-A	ZA8C single channel conversion kit	4
K9470BG	ZR22 RJC (RTD)	
M1234FM-A	HA400-A conversion kit (kg)	4
M1234FK-A	HA400-V conversion kit (vol%)	4
E7042UQ	Dust filter for oil/gas applications	
<p><b>Note 1:</b> The 4" ANSI Flange (-C) is suggested for probe lengths of 3m or greater.  <b>Note 2:</b> Derakane coating is recommended for any application up to 250°F (120°C) when elements corrosive to the detector may be present, such as those found in chemical incinerators.  <b>Note 3:</b> The check valve is recommended for use on the calibration gas port for positive pressure applications to prevent contamination of the calibration line during operation.  <b>Note 4:</b> ZR22 probe requires a conversion kit if used with AV8C/HA400/ZA8C analyzers. The ZR22 detector uses a PT1000 temperature sensor instead of a transistor type cold junction.</p>		



### 3. Integrated type Zirconia Oxygen / High Temperature Humidity Analyzer, Converter

#### Model ZR202G INTEGRAL TYPE OXYGEN ANALYZER/DETECTOR

HOW TO ORDER:  
Specify the model number,  
add the option code  
selection(s) to the model  
number and total the prices  
to arrive at list price.

Code	Model Description	Note
ZR202G	Integral type Zirconia Oxygen Humidity Analyzer	
	Length	
-040	0.4 meter	
-070	0.7 meter	
-100	1 r mete	
-150	1.5 meter	
-200	2 r mete	
-250	2.5 meter	
-300	3 meter	
	Wetted Material	
-S	Stainless Steel	
-C	Stainless Steel with Inconel cal gas tube	
	Flange	
-A	ANSI CLASS 150-2-RF (equivalent) flange	
-B	ANSI CLASS 150-3-RF (equivalent) flange	
-C	ANSI CLASS 150-4-RF (equivalent) flange	
-W	Westinghouse flange	
	Auto Calibration	
-N	No auto-calibration unit mounted (see /IAC24 option below)	
	Reference Air	
-E	External connection	
-P	Pressure compensation (for applications above 20" H2O)	
	Gas Thread	
-T	1/4 inch NPT	
	Converter Thread	
-T	NPT (1/2NPT)	
	Instruction Manual	
-E	English	
	Style Code	
-A	Always -A	
	Options	
/IAC24	Integral auto-calibration unit mounted for indoor installations	
/D	Derakane coating for high sulfur applications	2
/C	Inconet bolt, Oring	
/CV	Check valve	3
/H	Hood	
/SCT	Stainless steel tag plate	
/PT	Printed tag	
	Spare Parts - ZR202	
E7042UD	Universal cell assembly kit (for ZO21D, ZR22, ZR202)	
M1200DB-06	High temperature fly ash filter for ZR202	4
M1234SE-A	Self-cleaning high temp fly-ash filter	
<p><b>Note 1:</b> The 4" ANSI Flange (-C*U) is suggested for probe lengths of 3m or greater.  <b>Note 2:</b> Derakane coating is recommended for any application up to 250°F (120°C) when elements corrosive to the detector may be present, such as those found in chemical incinerators.  <b>Note 3:</b> The check valve is recommended for use on the calibration gas port for positive pressure applications to prevent contamination of the calibration line during operation. The /CV option is not needed when the autocalibration unit is mounted.  <b>Note 4:</b> M1234-SE-A and M1200DB-06 are not compatible to ZO21D probe. M1200DA-02 cannot be used with ZR22 or ZR202 probes.</p>		

#### 4. Probe Protector for Zirconia Detectors

##### MODEL ZR22R LOW TEMPERATURE PROBE PROTECTOR

###### HOW TO ORDER:

Specify the model number, add the insertion length, and the flange connections code selection(s) to the model number and total the prices to arrive at list price.

###### PRODUCT NOTES

PROBE PROTECTOR - This accessory is used when the sample gas flow velocity is approximately 10 m/sec (33 ft./sec) or more and dust particles may attack the probe, such as in the case of coal fired boilers. The probe protector MUST be the same length and flange type as the probe.

Code	Model Description	Note
ZR22R	Low temperature probe protector	
	Insertion Length	
-040	0.40 m (1'4 inch)	
-046	0.46 m (1'6 inch)	
-100	1.00 m (3'3 inch)	
-150	1.50 m (4'11 inch)	
-200	2.00 m (6'7 inch)	
-250	2.50 m (8'2 inch)	
-300	3.00 m (9'10 inch)	
	Flange Connection	
-C*U	ANSI 4.0 inch, 150#FF flange	
	Accessories	
M1132LL	Support clamp for ZR22G for retrofit	

The model ZR22R Probe Protectors are required for coal-fired applications, or other applications with particulate laden flue gas, where the gas flow is 10 meters/second or more.

Insertion Length: 1.5 m, 1.55 m, 2.05 m.

Flange: ANSI CLASS 150-4-FF (without serration) equivalent

Material: SUS316 (JIS), SUS304 (JIS) (Flange)

Weight: 1.05 m; Approx. 10 kg

1.55 m; Approx. 13 kg

2.05 m; Approx. 16 kg

#### 5. Probe Support for Zirconia Detectors

##### MODEL ZR22V LOW TEMPERATURE PROBE SUPPORT

###### HOW TO ORDER:

Specify the model number, add the insertion length, and the flange connections code selection(s) to the model number and total the prices to arrive at list price.

Code	Model Description	Note
ZR22V	Low temperature probe support	
	Insertion Length	
-150	1.50 m (for use with 3.0m probe or longer)	
	Flange Connection	
-C*U	ANSI 4.0 inch, 150#FF flange	
	Accessories	
M1132LL	Support clamp for ZR22 for retrofit	

ZR22V Probe Supports are needed if the detector is 2.5 meter or greater, horizontal installation is required, and no probe protector (ZR22R) is used.

## 6. Adapter for High Temperature Probe of Separate Type Oxygen Analyzer (for applications above 700°C)

### MODEL ZR22P HIGH TEMPERATURE PROBE ADAPTER

#### HOW TO ORDER:

Specify the model number, add the Tee configuration, transport tube material, insertion length, flange connection and options code selection(s) to the model number and total the prices to arrive at list price.

Code	Model Description	Note
ZR22P	High temperature probe adapter	
	Tee Configuration	
-H	Basic design (side eductor port)	
-T	Basic design (bottom port)	
-S	Split design (for blowback)	
	Transport Tube Material	
-A	Silicon carbide (SiC) (Up to 2600°F/1427°C)	
-B	310 S stainless steel (up to 1980°F/1082°C)	
-C	Alumina ceramic (up to 3400°F/1871°C)	
-N	No transport tube	
	Insertion Length	
-033	0.3 m (1'8 inch)	
-050	0.5 m (1'8 inch)	
-100	1.00 m (3'3 inch)	
-150	1.5 m (4'11 inch)	
-300	3.0 m (9'10) (requires probe support or protector)	
-NNN	No transport tube	
	Flange Connection	
-C*U	ANSI 4.0 inch, 150# RF flange	
	Options Heater System	
/HT	Aux heater system (to 600°F) (includes controller & heaters)	
	Options Blowback Valve	
/AV	Automatic valve (only with ZR22P-S)	
	Options Eductor	
/BE	Air eductor pre-attached with regulator & gauge (cannot be used with /HT or /AV)	
/ER	Air eductor with return exhaust pre-attached with regular & gauge	
/SE	Separate air eductor, regulator & gauge (not pre-attached)	
	Options Tag	
/SCT	Stainless steel tag (attached with wire)	

#### ZR22P-H High Temperature Probe Adapter for Separate type Oxygen Analyzer

Measuring O<sub>2</sub> in the high temperature gases (exceeds 700°C) requires a general-use probe ZR22G of 0.15 m length and a high-temperature probe adapter (model ZR22P).

Sample gas temperature: 0 to 1800°C

Sample gas pressure: -0.725 to 36.3 psi  
(+0.725 to +36.3 requires pressure compensation.)

Insertion length: 1 m, 1.5 m

Material in Contact with Gas: SUS 316, Zirconia, SUS 304 (flange)

Probe Material: varies 4 inch ANSI

Installation: Flange mounting

Construction: Non explosion-proof. Rainproof construction.

Weight: Insertion length of 1.0 m: approx. 6.5 kg (JIS) / approx. 8.5 kg (ANSI)

Insertion length of 1.5m: approx. 7.5 kg (JIS) / approx. 9.5 kg (ANSI)

7. Integral Auto-calibration unit for ZR22G/ZR202G

MODEL IAC24 INTEGRAL AUTOCAL UNIT

HOW TO ORDER:

PRODUCT NOTES:

Note 1: IAC-24-[ ] ambient temperature cannot exceed 70°C.

Note 2: Use cable WZ-H-6H- [ ] with ZR22G

Note 3: All connections are Swageloc 1/4

Note 4: For indoor installations

Code	Model Description	Note
IAC24	Base model for indoor installations	
	Autocal	
-22	Autocal for ZR22G	123
-202	Autocal for ZR202G	1,3
	Style	
-E-A	Always -E-A	

Note: Also available pre-mounted when /IAC24 option is selected in ZR22G/ZR202G model code. For remote mounted auto-calibration & manual calibration units, please refer to general specifications for model MCI-ACI calibration units (GS11M6AA-01E-A)

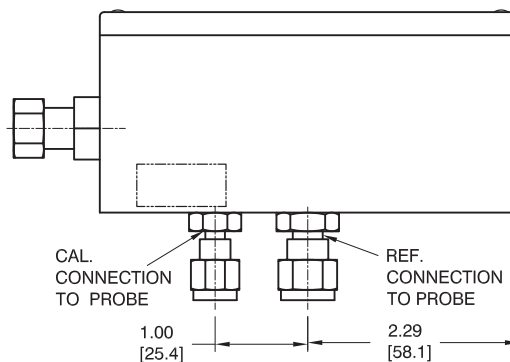
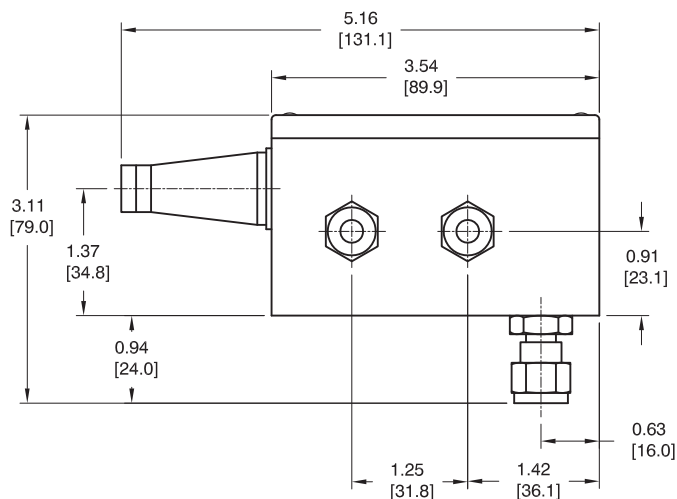
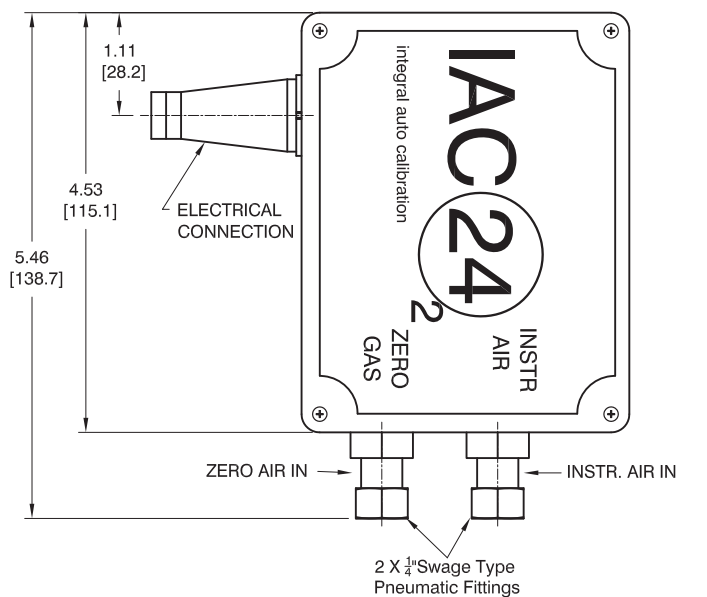

NOTE: REF. & CAL CONNECTIONS TO PROBE 2 X 1/4" SWAGE TYPE PNUEMATIC FITTINGS. THE IAC24 COMES WITH 1/4" PIPE ADAPTERS TO CONNECT TO THE PROBE.

IAC24-22-E-A

## EXTERNAL DIMENSIONS

### 1. Model ZR22G Separate type Zirconia Oxygen Detector

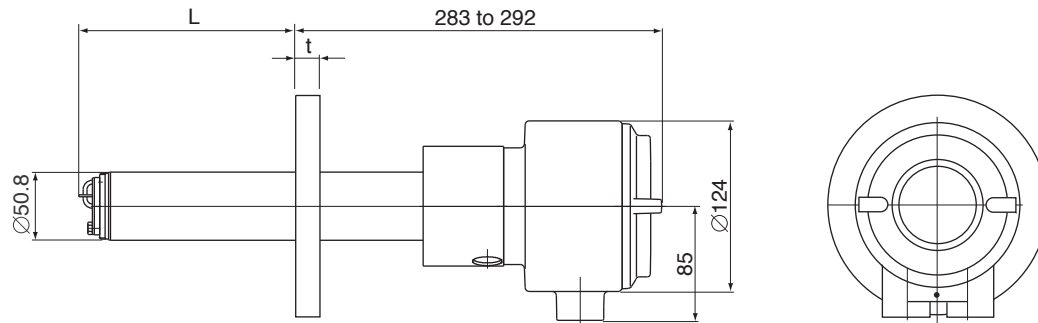

L=0.15, 0.4, 0.7, 1.0,  
1.5, 2.0, 2.5, 3.0  
3.6, 4.2, 4.8, 5.4 (m)

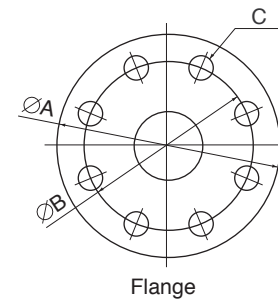
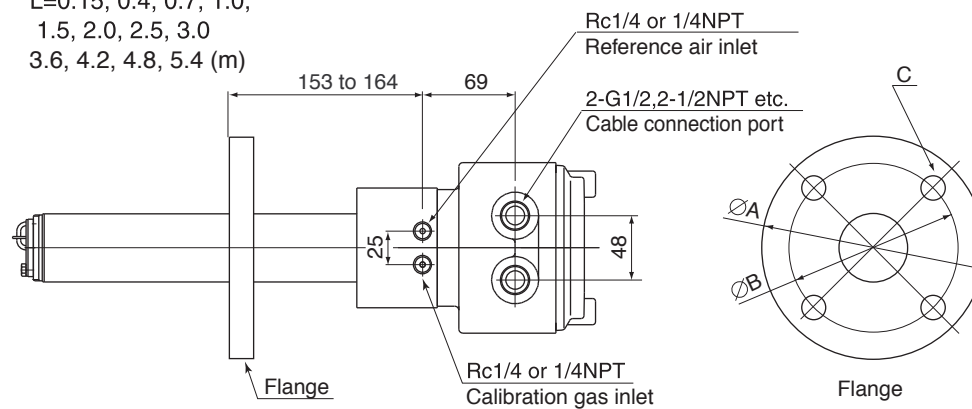

Flange	A	B	C	t
ANSI CLASS150-2-RF equivalent	152.4	120.6	4 - Ø19	19
ANSI CLASS150-3-RF equivalent	190.5	152.4	4 - Ø19	24
ANSI CLASS150-4-RF equivalent	228.6	190.5	8 - Ø19	24
JIS 5K-32-FF equivalent	115	90	4 - Ø15	5
Westinghouse	155	127	4 - Ø11.5	14

F07\_01.EPS

2. Model ZR22...-P (with pressure compensated) Separate type Zirconia Oxygen Detector

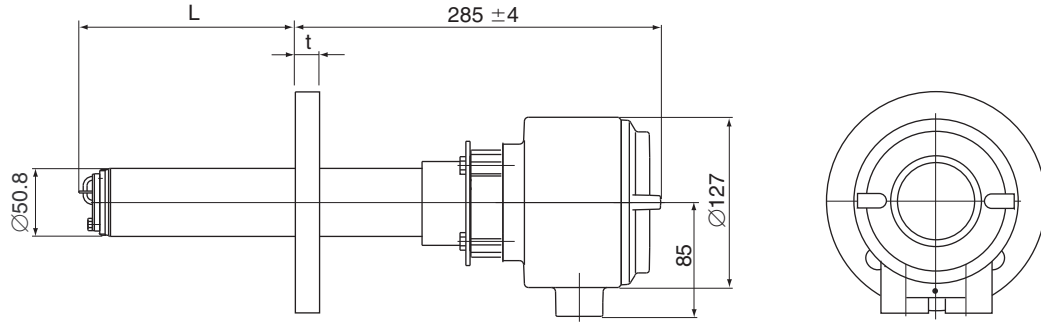

L=0.15, 0.4, 0.7, 1.0,  
1.5, 2.0, 2.5, 3.0  
3.6, 4.2, 4.8, 5.4 (m)

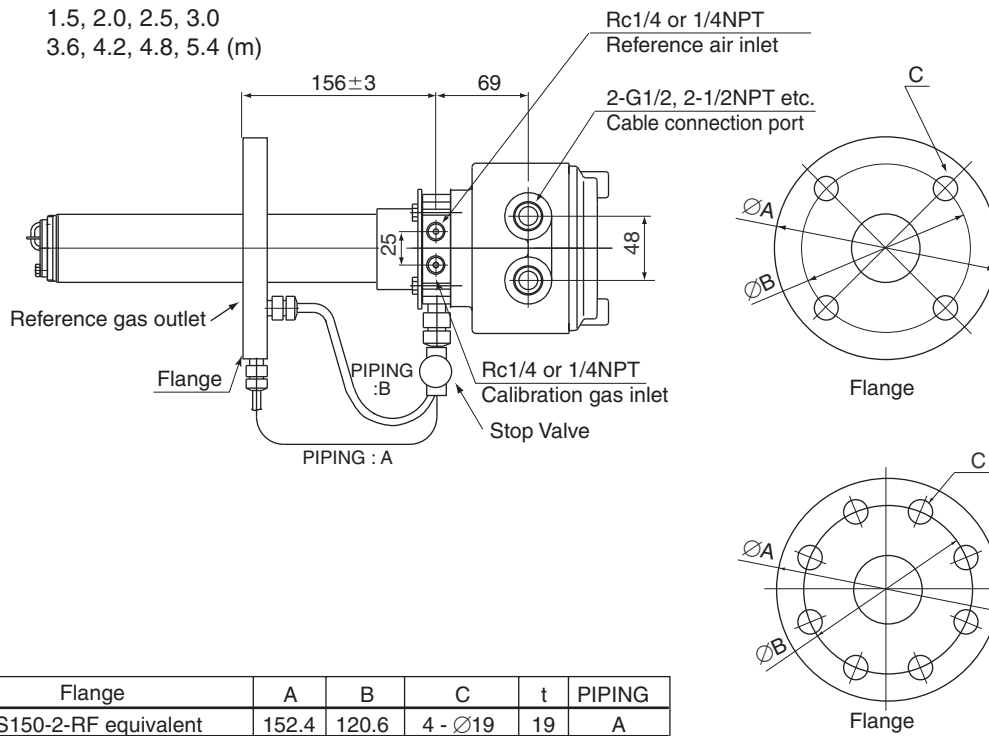

Flange	A	B	C	t	PIPING
ANSI CLASS150-2-RF equivalent	152.4	120.6	4 - Ø19	19	A
ANSI CLASS150-3-RF equivalent	190.5	152.4	4 - Ø19	24	B
ANSI CLASS150-4-RF equivalent	228.6	190.5	8 - Ø19	24	B
Westinghouse	155	127	4 - Ø11.5	14	A

F07\_02.EPS



### 3. Model ZR402G Separate type Zirconia Oxygen Converter

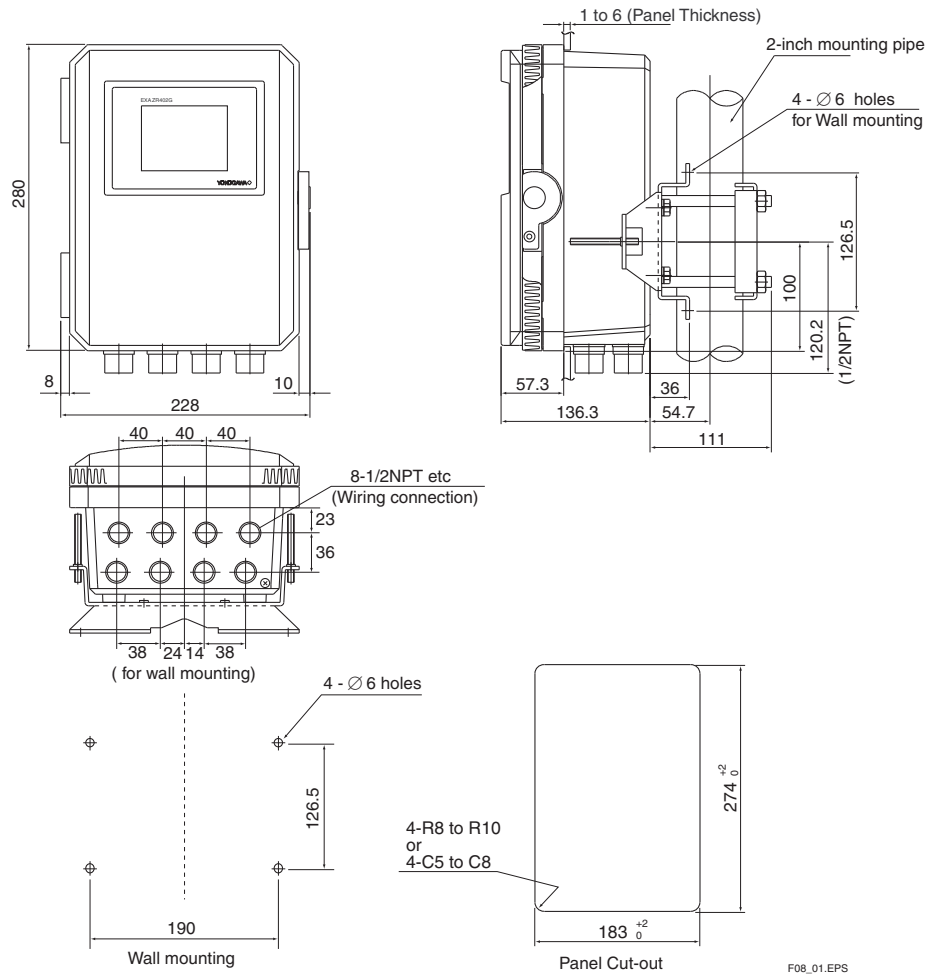

F08\_01.EPS

- With sun shield hood (option code /H)

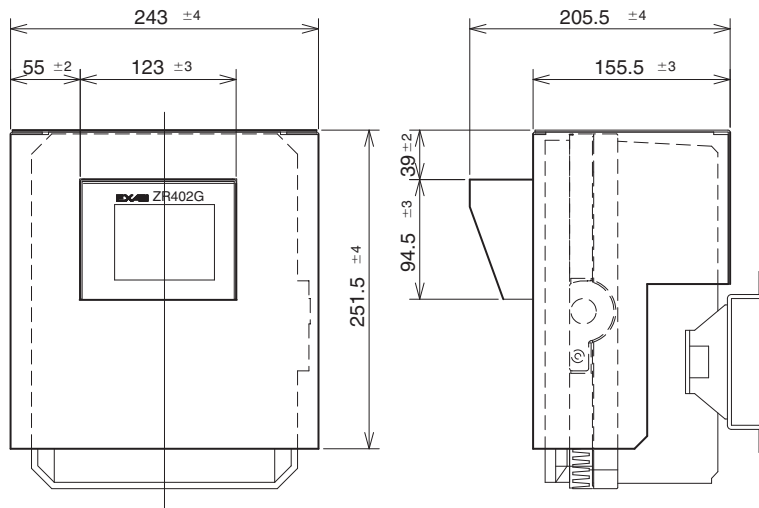

F10.EPS

Material of HOOD : Aluminum

### 4. Model ZR202G Separate type Zirconia Oxygen Analyzer

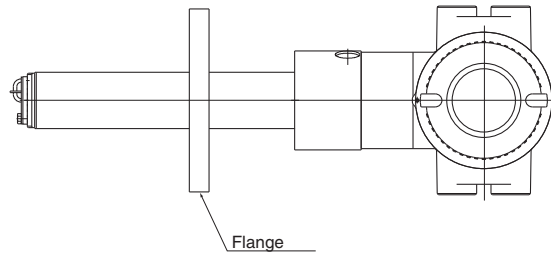
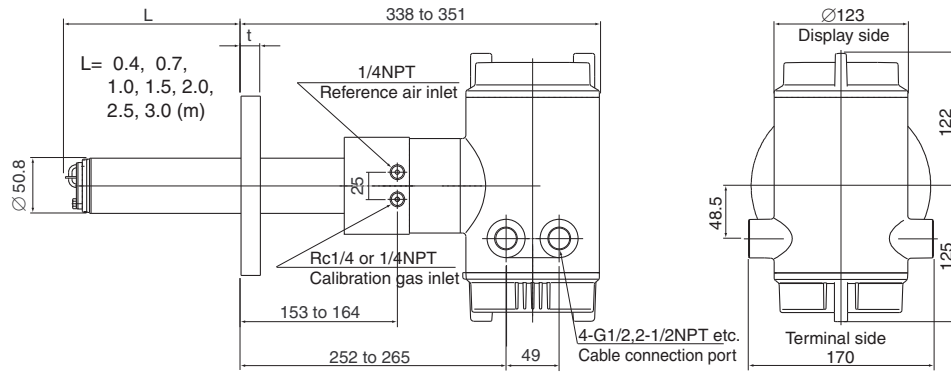

Flange	A	B	C	t
ANSI CLASS150-2-RF equivalent	152.4	120.6	4 - $\varnothing 19$	19
ANSI CLASS150-3-RF equivalent	190.5	152.4	4 - $\varnothing 19$	24
ANSI CLASS150-4-RF equivalent	228.6	190.5	8 - $\varnothing 19$	24
Westinghouse	155	127	4 - $\varnothing 11.5$	14

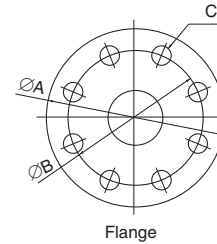
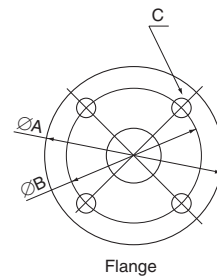

- With sun shield hood (option code /H)

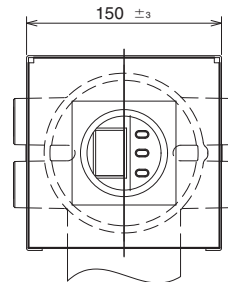
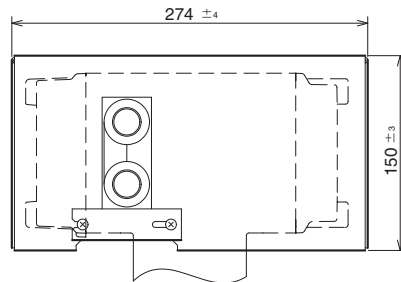

Material of HOOD : Aluminum

F13.EPS

## 5. Model ZR202G...-P (with pressure compensated) Integrated type Zirconia Oxygen Analyzer

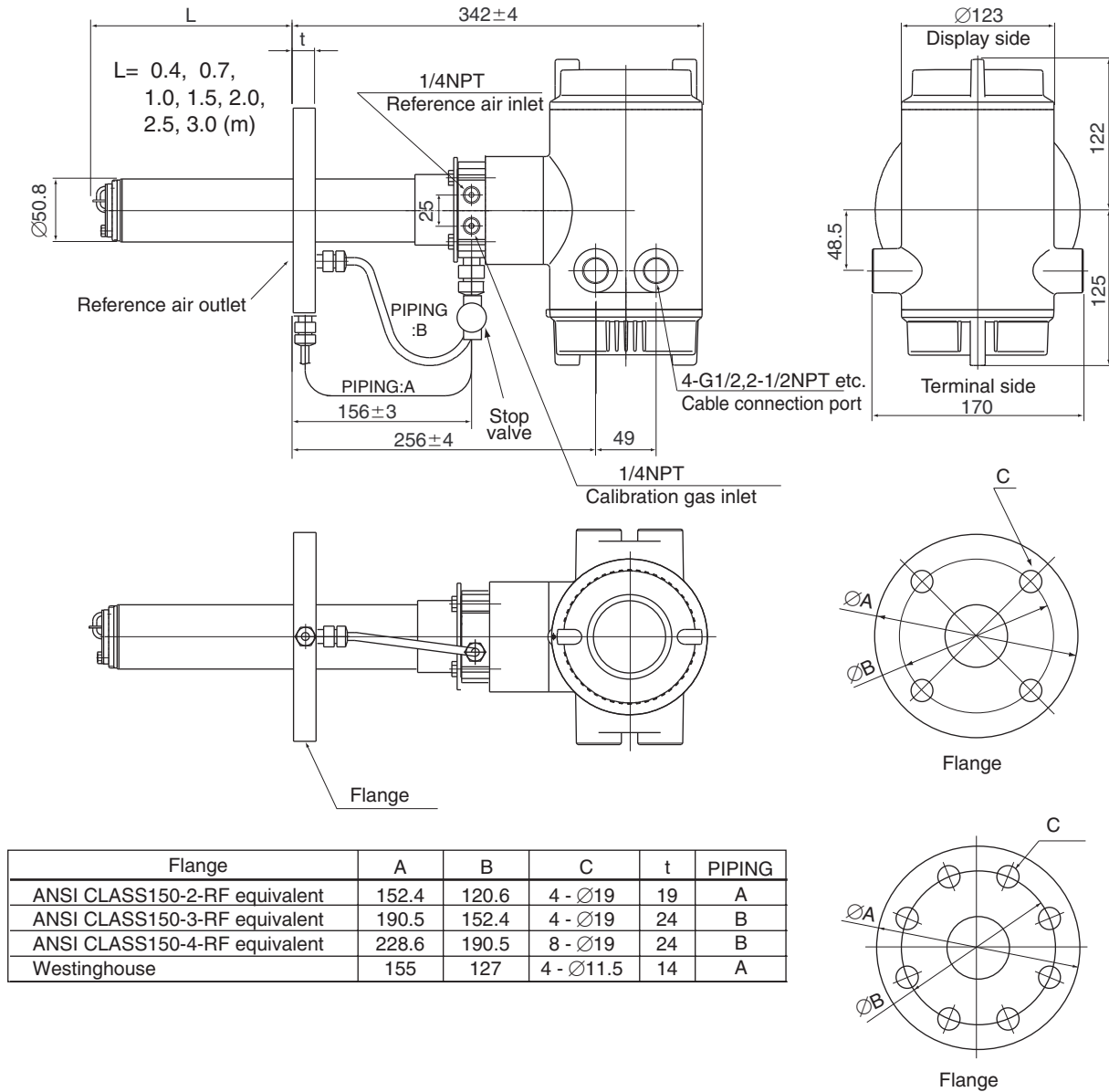

F11\_02.EPS



## ■ OPTIONS

### 1. Filter for Oxygen Analyzer E7042UQ

This filter is used to protect the cell from corrosive dust components in natural gas or oil applications. Measured gas flow rate is needed to be 1m/sec or more to replace gas inside zirconia sensor.

Mesh: 30 microns

Material: Carborundum (Filter), SUS316 (JIS)

Weight: Approx. 0.2kg

### 2. M1234SE-A Self Cleaning Fly-Ash Filter

This uniquely designed filter protects the Zirconia sensor in harsh coal-fired applications. The design prevents accumulation of fly-ash that would clog other fly-ash filters.

Filter material: Hastaloy X

Base Material: SSTL 316

Max OD: 6.35cm (2.5 in)

Filter surface area: 296 sq-cm (46 sq-in)

Max opera. temp.: 700°C (1292°F)

Pore size: 10 micron

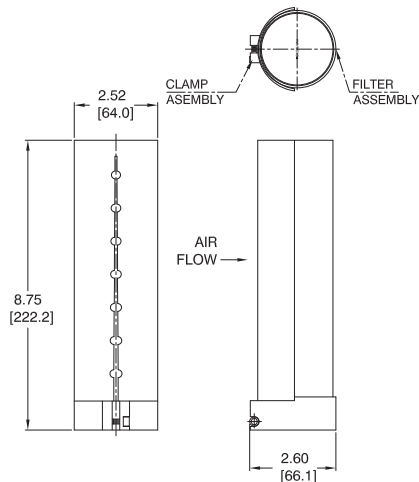

### 3. M1200DB-06 Hastaloy X Sintered Filter Assembly

This filter addresses blockage and coating problems experienced by tough applications.

Mesh: 10 microns (filter)

Material: Hastaloy X

Maximum Temperature Rating: 1292°F (700°C)

Connection: Stainless Steel c-clamp with bolts

Weight: Approximately 18 lb (.8kg)

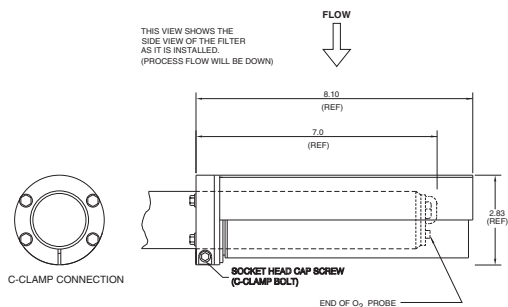

ZABA10 2drawing.eps

### 4. M1234VV-A Check Valve (/ CV option)

The check valve prevents the water vapor in the process from diffusing down the calibration line where it may condense and cause the cell to crack. A check valve should be used on all natural gas and positive pressure applications and any time a cal line is installed with long periods (>3 months) of time between calibrations.

Connection: 1/4 FNPT inlet; 1/4" MNPT outlet

Material: 304SS

Cracking Pressure: 1 psi

Weight: Approximately 0.1lb (50g)

Note: The check valve is not a substitution for an inline filter for removing moisture from instrument air source.

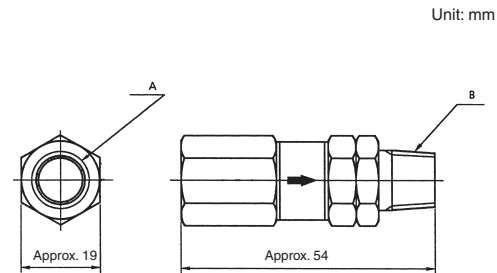

F30.EPS

### 5. Auxiliary Eductor Assembly, Model No. M1132KE

High temperature installations require the use of the auxiliary eductor assembly in all negative pressure installations. using instrument air, the auxiliary eductor draws a sample through the adapter tee for quick measurement without mechanical assistance. The assembly includes an eductor, regulator and pressure gauge and is included in the eductor option for the ZR22P high temperature adapter tee.

Note: Positive pressure requires the use of a needle valve to restrict the flow of sample gas.

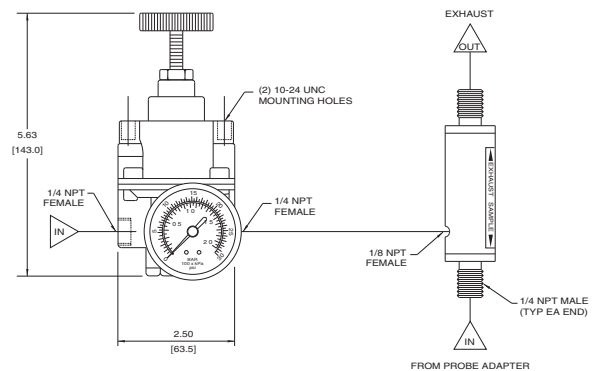

**6. Eductor, Model No. M1132KA (spare)**

The ejector induces flow of the sample from the process through the transport tube. The draft causes the sample flow from the process to be pulled through a high temperature adapter tee (i.e. transport tube).

Material: 316SS  
Air Supply: 1/8" NPT female  
Exhaust: 1/8" NPT male straight  
Vacuum Force: 7.6" Hg  
Vacuum Flow: 2.4 SCFM  
Air Consumption: 1.7 SCFM  
Weight: 6oz (170g)  
Vacuum: 1/8" NPT male

**7. Pressure Regulator, Model no. M1132KD (spare)**

This general purpose regulator is used to adjust the flow of instrument air entering the eductor. Made of durable materials and corrosion resistant construction, it provides reliable operation in harsh industrial environments.

Flow Capacity: 20SCFM (33.6 m<sup>3</sup>/hr) at 100psig (700 kPa) supply - 20 psig (140 kPa) outlet.

Exhaust Capacity: 0.1 SCFM (0.17 m<sup>3</sup>/hr) - downstream pressure 5 psig (35 kPa) above setpoint.

Sensitivity: 1" (2.5 cm) of water

Effect of Supply Pressure Variation: Less than 0.2 psig (1.4 kPa) for 25 psi (170 kPa) change.

Maximum Supply Pressure: 250 psig (1700 kPa)

Air Consumption: Less than 6 SCFH (0.17 m<sup>3</sup>/hr)

Output Range: 0 to 60 psi (0 to 400 kPa)

Port Size: 1/4" NPT

Materials: Body - Die cast aluminum alloy; Diaphragm - Nitrile elastomer and nylon fabric; Trim - Brass, zinc plated steel, acetal.

Weight: 4.0lb (1.8kg)

**8. Pressure Gauge, Model no. M1132ME**

Indicates the pressure of instrument air flowing into the eductor.

Gauge size: 2"

Measure range: 0 to 60 psi (0 to 400 kPa)

Connection: 1/4" FNPT

Weight: 0.5 lb (0.2 kg)



# WIRING CONNECTIONS

Model ZR402G Separate type Zirconia Oxygen Analyzer Converter

Model ZR22G Separate type Zirconia Oxygen Detector

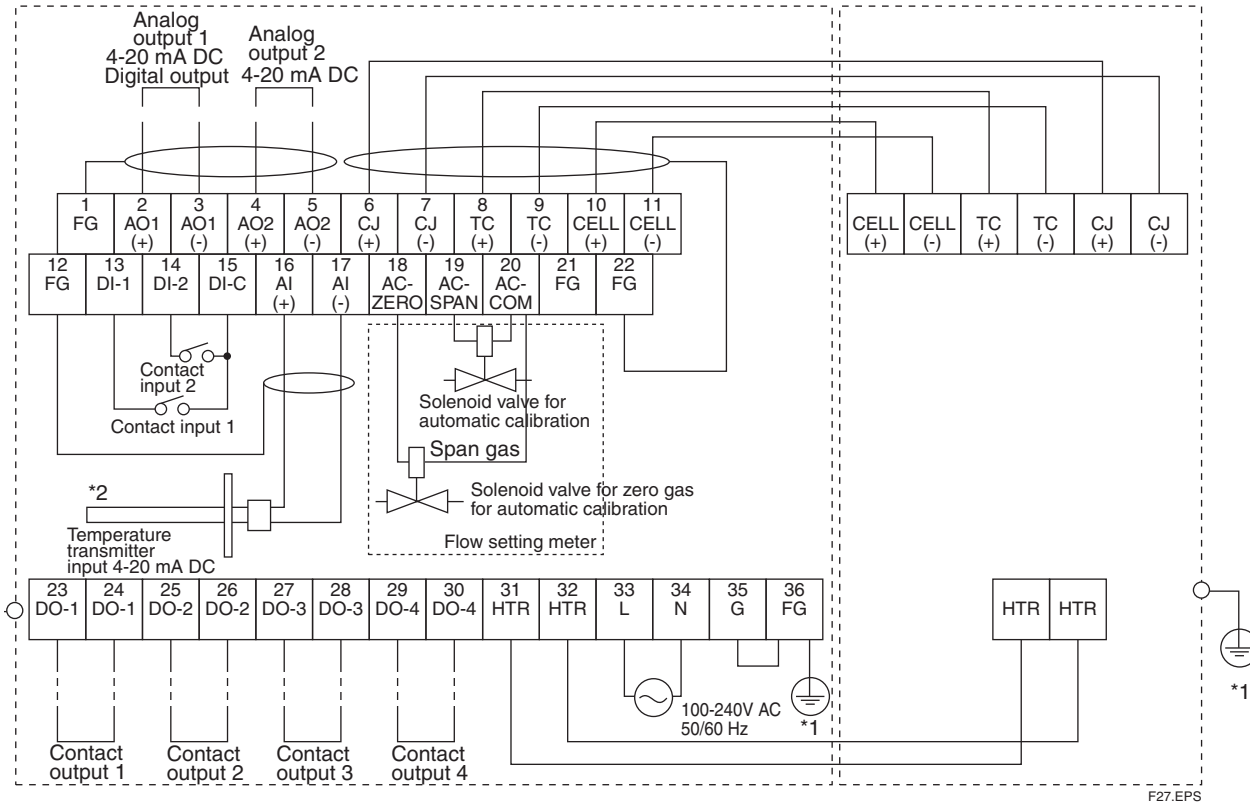

F27.EPS

\*1 Total resistance is 100 ohm or less.

\*2 Option (Temperature transmitter provide by user) for humidity measurement.

Model ZR202G Integrated type Zirconia Oxygen Analyzer

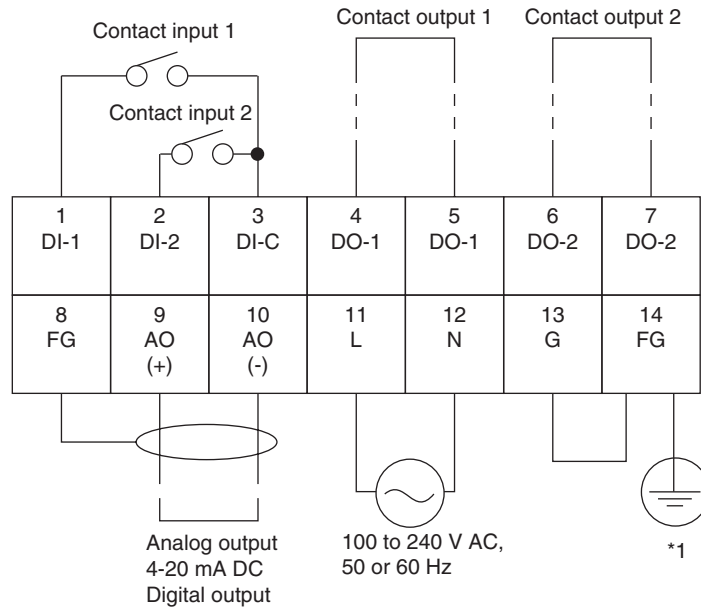

\*1 Ground resistance is 100 ohm or less.

F28.EPS

**YOKOGAWA HEADQUARTERS**

**9-32, Nakacho 2-chome,  
Musashinoshi  
Tokyo 180  
Japan**  
Tel. (81)-422-52-5535  
Fax (81)-422-55-1202  
E-mail: [webinfo@mls.yokogawa.co.jp](mailto:webinfo@mls.yokogawa.co.jp)  
[www.yokogawa.com.jp](http://www.yokogawa.com.jp)

**YOKOGAWA EUROPE B.V.**

**Euroweg 2  
3825 HD Amersfoort  
The Netherlands**  
Tel. +31 (0)88-4641000  
Fax +31 (0)88-4641111  
E-mail: [info@nl.yokogawa.com](mailto:info@nl.yokogawa.com)  
[www.yokogawa.com/eu](http://www.yokogawa.com/eu)

**YOKOGAWA CORPORATION OF AMERICA**

**2 Dart Road  
Newnan GA 30265  
United States**  
Tel. (1)-770-253-7000  
Fax (1)-770-251-2088  
E-mail: [info@yca.com](mailto:info@yca.com)  
[www.yokogawa.com/us](http://www.yokogawa.com/us)

**YOKOGAWA ELECTRIC ASIA Pte. Ltd.**

**5 Bedok South Road  
Singapore 469270  
Singapore**  
Tel. (65)-241-9933  
Fax (65)-241-2606  
E-mail: [webinfo@yas.com.sg](mailto:webinfo@yas.com.sg)  
[www.yokogawa.com.sg](http://www.yokogawa.com.sg)

Yokogawa has an extensive sales and distribution network. Please refer to the website ([www.yokogawa.com/an/index.htm](http://www.yokogawa.com/an/index.htm)) to contact your nearest representative.



**YOKOGAWA** ◆